

SWG 100

BIOcompact

USER MANUAL



Preamble

This manual includes a description of the product but no guarantees of specific qualities or results of use. Unless otherwise stated, the relevant state of engineering is that at the time of the joint delivery of the product and operating instructions by MRU GmbH.

The design and circuitry are subject to ongoing development and improvement. Subject to technical changes.

This manual is protected by copyright. All rights reserved. Copying, reproduction, translation, or conversion to any type of electronic medium or machine-readable form in its entirety or in parts without the prior written approval by MRU GmbH is not permitted.

Version:

Producer:



MRU · Messgeräte für Rauchgase und Umweltschutz GmbH

Fuchshalde 8 + 12

74172 Neckarsulm-Obereisesheim

Fon 07132 99620 · Fax 07132 996220

info@mru.de · www.mru.eu

Version: 1.2

CONTENT

1	About this manual	7
1.1	Storage location of the manual	7
1.2	General information about the manual	7
1.3	Packaging	7
1.4	Taking back parts containing harmful substances	7
1.5	Taking back electrical equipment	8
1.6	Weather and environmental conditions	8
1.7	General important instructions for the plant operator	9
1.8	MRU Warranty conditions	10
1.9	Representation of safety and warning notes	11
2	Information on the unit and safety	12
2.1	Safety manual	12
2.2	General information	12
2.3	Qualified personnel	13
2.4	Safety basics	14
2.4.1	1.1.1 Risk of poisoning from the extraction gas	14
2.4.2	Fire (explosion) hazard due to sample gas	14
2.4.3	1.1.3 Acidic condensate	14
2.4.4	Flammable gas	17
2.4.5	Toxicity danger of sample gas	17
2.4.6	Battery cell	19
3	Service description	21
3.1	Configurations and type plate	22
4	Device description	23
4.1	Operation unit	24
5	Installation	25
5.1	General installation rules	25
5.2	Components and terms used	26
5.3	Mounting the device	27
5.3.1	Door distance	28
5.3.2	Dimensions and drilling plan	28
5.4	Connecting power supply	29
5.5	Connecting inputs and outputs	31
5.6	Connect alarm-relay and RS-485	35
5.7	Switching on the unit	36
6	Operation	38
6.1	Operating and display elements	38

6.2	Menu structure	39
6.2.1	Measuring menu structure	40
6.2.2	Open submenu	40
6.3	Setting options Measuring menu	41
6.3.1	Switch to Zoom/Standard display mode	41
6.3.2	Change measurement page	41
6.3.3	Displaying the last Measuring Point Values	42
6.3.4	Configuring the Measurement Window	43
6.4	Menu: Extras	44
6.4.1	General settings	44
6.4.2	Measurement configuration	45
6.4.3	Adjustment menu	45
6.4.4	Factory settings	45
6.4.5	Contents SD card	45
6.4.6	Event viewer	46
6.4.7	Device Info	46
6.4.8	Set the Modbus	47
6.4.9	Set Date & Time	48
6.4.10	Menu: Data-store	49
6.4.11	Calling up the data memory menu	50
6.5	Displaying stored values in text mode	51
6.5.1	Displaying stored values in graphic mode	52
6.5.2	Export measurement to SD card	52
6.5.3	Setting the CSV format	53
7	Setting the measuring cycle	54
7.1	Menu path and basic structure	54
7.1.1	Navigating in the menu	54
7.1.2	Delete Phase	55
7.1.3	Insert phase	55
7.1.4	Insert Autoconfiguration	55
7.2	Phase submenus: Setting options	57
7.2.1	Zeroing (Cycle Phase Details)	57
7.2.2	Measurement SP.x (Cycle Phase Details)	57
7.2.3	Stand by (cycle Phase details)	58
7.2.4	Purging (Cycle Phase Details)	58
7.3	Example for a measurement cycle configuration	59
7.4	Cycles-Timer: Interception of Events	60
7.4.1	Calling up the cycle timer	60
7.4.2	1.1.2 Menu structure	60
7.4.3	Setting the cycle timer (example)	61

7.5	Update software	63
7.5.1	Overview: Possible system updates	63
7.5.2	Updating the main unit	64
7.5.3	Updating the different modules	65
8	Option	66
8.1	Option: IO module	66
8.1.1	IO module position	66
8.1.2	Pin assignment	67
8.1.3	Analogue outputs 4-20 mA (AO1-AO4)	69
8.1.4	Alarm Output Setting (AL1-AL2)	70
8.1.5	AUX input for transmitter (AI1-AI4)	71
8.1.6	Set up AUX input	73
8.1.7	Configuration External Control (Option: I/O Module)	74
8.2	TCP to Modbus RTU Converter	82
8.2.1	Ethernet different states	82
8.2.2	Setting up Ethernet	82
8.3	Option: Profibus-converter	86
8.3.1	Connect device with Profibus	86
8.3.2	Connection to device	86
8.3.3	Device settings	87
8.3.4	Special information about Modbus-Slave function	87
8.3.5	Special information about Profibus – Slave function	87
8.4	Option: RS-485 to USB converter	88
8.4.1	RS-485 Converter connection and configuration	88
8.5	Option: MRU4Win	90
8.5.1	MRU4Win start and settings	90
8.6	Flame arrester	92
8.7	Option: LEL-Sensor	93
8.7.1	Safety device: LEL sensor	93
8.7.2	Maintaining and calibrating the LEL sensor	94
8.7.3	Replacing the LEL sensor	96
8.8	Option: 11247A Condensate Trap with Filter	97
8.8.1	Fitting the condensate trap	97
9	Service and maintenance	99
9.1	Preparation and instruction for maintenance	99
9.2	Regular maintenance work by the operator	100
9.3	Maintenance parts: Position overview	101
9.3.1	The spare parts set #66114	101
9.3.2	Spare part position outside	102
9.3.3	Replace filter-mat	103

9.3.4	Replacing the inline filter activated carbon	104
9.3.5	Replacing the inline Sox / NOx filter	105
9.3.6	Change filter-unit on nozzle	106
9.4	Gas adjustment	107
9.4.1	Connect adjustment gas cylinder	108
9.4.2	Adjust Multi Gas Bench	109
9.4.3	Adjust the electrochemical O2-sensor	111
9.4.4	Adjustment electrochemical sensors	114
10	Technical data	117
10.1	General technical data	117
10.2	Technical data: NDIR-bench	118
10.3	Technical data: electrochemical sensors	119
11	Appendix	122
11.1	Mechanical drawing	123
11.2	Gas flow diagram	124
11.3	Wiring diagram	125
11.4	Position plan	128

1 About this manual



This manual enable the safe and efficient handling of the product.

The user must read these instructions carefully and understand them before starting work.

The basic prerequisite for safe working is compliance with all the safety manual given.

1.1 Storage location of the manual

The manual is an integral part of the product and must be kept in the immediate vicinity of the product and accessible to personnel at all times.

1.2 General information about the manual

- Read and observe the separately supplied Safety manual.
- This manual enables you to understand and safely operate this MRU Analyser.
- Please read this manual with great vigilant.
- Get familiar with the product before using it.
- This analyser may only be operated by competent personnel and for its intended use.
- The analyser may only be used by qualified personnel for the intended use.
- Please pay special attention to all safety directions and warnings to prevent personal injuries and damaging of the product.
- We cannot be held responsible for any injuries and/or damages that occur by not following the instructions in this manual.
- Always keep the manual near you when working with the analyser, to be able to read instructions as needed. Please ensure to hand over all documents to when handing the analyser over to others.
- Hand over all documents when passing on the analyser to third parties.

1.3 Packaging

Keep the original carton and packaging material to avoid damage in transit in case you have to send the unit to the factory.
to the factory.

1.4 Taking back parts containing harmful substances

MRU GmbH undertakes to take back all parts supplied by us which contain hazardous substances and which cannot be disposed of in the normal way.

Parts containing hazardous substances are, for example, electrochemical sensors, batteries and accumulators.

The return delivery must be free of charge for MRU.

1.5 Taking back electrical equipment

MRU GmbH undertakes to take back for disposal all electrical appliances sold after 13 August 2005. The return of the appliances must be free of charge for MRU.

1.6 Weather and environmental conditions

NOTE

IP class and permissible ambient temperature see technical data.

This degree of protection is only given when the door is closed.

- Protect the inside of the appliance from moisture and dirt.
- Before opening the appliance door, make sure that the external atmosphere is not explosive. To do this, the environment must be measured with a measuring device certified for this purpose.
- The analyser can only be switched on when the door is closed and the purging phase has been completed, or when the unit is in service mode.

1.7 General important instructions for the plant operator

To guarantee continuous operation of the analyser, the functions, processes, and operation of the analyser must be monitored regularly by the plant operator – especially in case of any initial installation. Thus, it will be possible to take suitable measures to improve the availability and lifetime of the analyser.

As the plant operator gains more experience concerning the maintenance requirements of the analyser, the monitoring frequency may be reduced to more extended periods of time.

NOTE

In case of **not intended** use the guarantee will void. Regular controls, inspections and the exchange from polluted and exhausted filters by the operator are also an important part of the determinations “**not determined use**”- see chapter “Maintenance” for regular maintenance work.

1.8 MRU Warranty conditions

The warranty is 12 months.

- 1 The warranty on spare parts is 6 months.
- 2 The term of the warranty conditions starts as of the invoice date.
- 3 The warranty is void under the following conditions:
 - Improper use.
 - Improper application.
 - Improper mounting.
 - Deliberate or negligent destructions.
 - External influence like dropping, impact, solvents, acids, gases, or transport damages. This includes damage, which is caused by exposure to high pollution and/or moisture (condensate) in the gas path.
- 4 As well excluded from the guarantee conditions are typical consumable- and spare parts.
- 5 Use of original MRU consumable parts and sensors is required to maintain the warranty.
- 6 Removal of tampering of the serial number type plate will void the warranty.
- 7 The service of a guarantee conditions will not enlarge the guarantee time. Demands because of consequential damages are excluded.
- 8 MRU is not responsible for the transport costs for the warranty or replacement.
- 9 MRU reserves the right, to determine individual conditions or exceptions. These will be separately communicated.

MRU GmbH

01.09.2014

1.9 Representation of safety and warning notes

Unit-specific safety instructions are placed before dangerous action.

DANGER

Indicates an imminently hazardous situation which, if not avoided, will result in death or serious injury.

WARNING

Indicates an imminently hazardous situation which, if not avoided, could result in death or serious injury.

CAUTION

Indicates a potentially hazardous situation which, if not avoided, may result in minor injury.

ATTENTION

Indicates a harmful situation which, if not avoided, may result in damage to the unit or its surroundings.

NOTE

Identifies user tips and other important information.

 See also Fehler! Verweisquelle konnte nicht gefunden werden., page Fehler! Textmarke nicht definiert.

2 Information on the unit and safety

2.1 Safety manual

The safety manual supplied with the unit contains all the general information and safety instructions for the units.

- ! Read and observe the safety manual before the first use of the unit.

2.2 General information

- ! Read and observe separately supplied safety manual
- ! The user manual enables you to operate the unit safely.
- ! Read the user manual carefully.
- ! Get familiar with the unit before you use it.
- ! Before turning on the unit, carry out an overall visual inspection of the unit, the gas sampling probe and any attachments.
- ! Do not operate the unit if there is any damage to the housing, power supply unit, supply cables or other damage.
- ! Operate the unit only with the supplied power supply adapter.
- ! Do not use the metal tube of the gas sampling probe or other metallic parts as electrical conductors.
- ! Do not exceed the specified temperature range of the gas sampling probe. The temperature sensor and probe tube will be destroyed if the temperature range is exceeded.
- ! The unit may only be used by qualified personnel for the intended use.
- ! Operate the unit only within the parameters specified in the technical data.
- ! Do not use any violence.
- ! Only carry out maintenance and servicing work described in the user manual. Observe the specified action steps. Only use original spare parts.
- ! Do not store the unit together with solvents, acids or other aggressive substances.
- ! Keep this user manual close at hand so that you can refer to it whenever necessary.

- ! Ensure to hand over all documents to when handing the unit over to others.

2.3 Qualified personnel

⚠ WARNING

Qualified personnel

The units may only be installed and commissioned by qualified and competent personnel.

For the purposes of these instructions, qualified personnel are persons who are familiar with the installation, commissioning and operation of this product and who have qualifications appropriate to their work, such as:

- ! Training or instruction or authorisation to install circuits and devices or systems and systems in accordance with the current standards of safety technology, to earth and and mark them.
- ! Training or instruction in accordance with current safety engineering standards in Care and use of appropriate safety equipment.
- ! Training in first aid.

2.4 Safety basics

2.4.1 1.1.1 Risk of poisoning from the extraction gas

⚠ DANGER

Toxic gases

Sample gases may contain toxic substances that are hazardous to health and can cause death. Inhalation of toxic gases is harmful to health and can lead to death.

- It is the responsibility of the plant operator to ensure that only persons trained in the safety regulations of the plant operate this analyser.
- Existing regulations on toxic gases must be known to the operator and observed.
- The use of an additional gas detector is strongly recommended in special plants, such as biogas plants, etc., as H₂S in high and dangerous concentrations cannot be detected by the human nose. It is up to the operator to know his plant and to assess the potential danger correctly.
- CO₂ gas is heavier than air. Therefore, its use in basements should be avoided. CO₂ is also odourless!
- Use of the analyser is prohibited in confined spaces or rooms without forced ventilation.
- The analyser releases the sample gas into the ambient air. Therefore, the analyser may only be used outdoors or indoors with forced ventilation.

2.4.2 Fire (explosion) hazard due to sample gas

⚠ DANGER

Flammable gases

Some gas mixtures contain methane (CH₄), which is flammable.

With regard to flammable (e.g. CH₄ methane) gases in hazardous areas, the system user must be able to recognise the classification of the hazardous areas and be aware of operating the analyser there. This area classification is country-specific and must be observed.

- Stationary analysers may be used in zone 2 hazardous areas if they have the certificate of conformity (ATEX). These analysers must never be operated in rooms without forced ventilation.
- Only trained personnel should install and service the analyser. Turn off the power before opening the analyser.

2.4.3 1.1.3 Acidic condensate

⚠ WARNING

Acidic substances

Liquid or condensate coming out of the condensate outlet may be slightly acidic.

- In case of skin contact, clean affected areas immediately!
- Do not get liquid in your eyes.

Carefully clean all parts that have come into contact with the condensate immediately.

NOTE

The device is intended for gas measurements with a condensate content of max. 14ml/min.

If the system contains very humid gas (high condensate content of more than 14ml/min), then - to protect the device additional measures are required to protect the device.

If you do not have a practicable solution, please contact MRU.

⚠ DANGER

Risk of explosion in explosive atmospheres

There is a risk of explosion in explosive atmospheres.

- The measuring device is approved only for use in nonexplosive atmospheres.
-

The unit is a gas analyser with which emission values for various gases can be determined. Mainly typical biogases and their concentrations are determined with the device. These can be e.g. CO₂, CH₄ and O₂.

- ! The gas components are detected with different measurement sensors, such as NDIR technology, electrochemical sensors, heat conduction detectors or paramagnetic sensors.
- ! The device must not be used for personal protection. The device is not a substitute for prescribed safety devices.
- ! The warranty becomes void if the device is not used for its intended purpose.
- ! Regular checks, inspections and replacement of dirty and used filters by the operator of the unit also fall under the provision "improper use".

2.4.4 Flammable gas

⚠ WARNING

Flammable gas

Biogas contains Methane (CH₄), which can be flammable.

Regarding flammable gases (e.g. CH₄ methane) and operating-instruments in the hazardous areas, the user must also be able to recognize the area classification and be aware of using the instrument there. This area classification is country specific, please observe and adhere to it.

- ! Stationary analyzers are allowed to be mounted in hazardous area zone 2 only if they have the certificate of compliance. These instruments shall never be located in confined places or rooms without forced ventilation.
- ! Only trained personnel should carry out installation of stationary instrument and/or maintenance, service and repair. Opening the stationary analyzer cabinet can expose personnel to injuries and shocks from electrical voltage!

2.4.5 Toxicity danger of sample gas

⚠ DANGER

Toxic gas

Sample gas can contain toxic substances, which are harmful for health and can even cause death.

- ! It is the responsibility of analyzer user to ensure that person is skilled and trained in safety aspects of gases being analyzed and procedures to follow while using this instrument. Bestehende Vorschriften über giftige Gase müssen dem Bediener bekannt sein und beachtet werden
- ! Using a personal gas detector inside the biogas plant is highly recommended since H₂S in higher (very dangerous) concentration cannot be detected by human nose. Only small concentrations around few ppm can be detected by human nose. CO₂ Gas ist schwerer als Luft. Deshalb ist der Einsatz in Untergeschossen zu vermeiden. CO₂ ist ebenfalls geruchslos!
- ! It is not allowed to use the biogas analyzer in confined space or rooms without forced ventilation.

- ! Das Entnahmegas wird vom Analysator in die Umgebungsluft abgegeben. Deshalb ist der Analysator nur im Außenbereich oder Innenbereich mit Zwangsentlüftung zu verwenden.
- ! Sample gas exiting the analyzer will flow in to the ambient air and only outdoor use or forced ventilation rooms are suitable for using the biogas analyzer.
- ! Local regulations for possible exposure to toxic gases has to be known and obeyed by the user of the analyzer.
- ! CO₂ gas is heavier than air and therefore operator shall avoid working at underground levels. Beware of that CO₂ is also odorless!

List of poisonous or injurious gases which are normally present in the sample gas (Biogas).

Gas	Liberated quantities
Gas (total)	<100ml/day
CH ₄ (methane)	<75ml/day
CO ₂ (carbon dioxide)	<55ml/day
H ₂ S (hydrogen sulfide)	<0,5ml/day
H ₂ (hydrogen)	<1ml/day
NH ₃ (ammonia)	<1ml/day

2.4.6 Battery cell

The analyzer contains battery cells at the following positions:

- Main board (1).

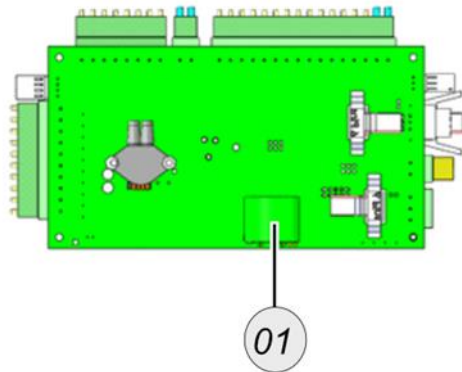

Follow steps must be aware:



⚠ WARNING

Switch off the power of the device

Before removing the battery the device must be switched off.



⚠ WARNING

Educated staff

It is recommended that only trained staff exchange the battery cell from the analyzer.



⚠ WARNING

Charging

Overcharging, short circuiting, reverse charging, mutilation or incineration of the cells must be avoided to prevent one or more of the following occurrences; release of toxic materials, release of hydrogen and/or oxygen gas, rise in surface temperature.



⚠ WARNING

Watch out of damage

If a cell has leaked or vented, it should be replaced immediately using protective gloves.



⚠ WARNING

Replacement of empty or damage cells

If and when necessary, these cells must be replaced with identical new ones from the same manufacturer. If a cell to be replaced is connected with other cells in series, it is recommended that the other cells be replaced with new ones at the same time.



⚠ WARNING

Watch out polarity

Reverse polarity installation of the cell in the end product must be avoided.



⚠ WARNING

Ventilation

Cell compartments containing these cells must be provided with means of ventilation to prevent possible accumulation of any released gases under abnormal conditions.

3 Service description

The SWG100-BIOcompact is a stationary gas analysis system for measure the biogas concentration emission monitoring.

It is intended for clean applications, these can be exemplified by:

- biogas AD (anaerobic digester) plants, ethanol plants, pulp & paper plants
- cogeneration heat and power engines (CHP)
- biomethane plants (gas to grid)
- landfill gas monitoring and CHP
- municipal or industrial waste water treatment plants
- coal seam gas sites

A defined gas flow is extracted, filtered, and further processed by a measuring tube.

Depending on the configuration, the gas analyser can measure the following gas components:

- Carbon dioxide (CO₂)
- Sulphur dioxide (SO₂)
- Oxygen (O₂)
- Methane (CH₄)
- Hydrogen (H₂)
- Carbon monoxide (CO)

Depending on the configuration, different measurement principles can be used in your unit to determine the gas concentrations.

These can be exemplary.

- NDIR measuring cells,
- Electrochemical sensors,
- paramagnetic sensors,
- thermal conductivity sensors.

3.1 Configurations and type plate

You can read the respective configuration of your unit on the type plate.

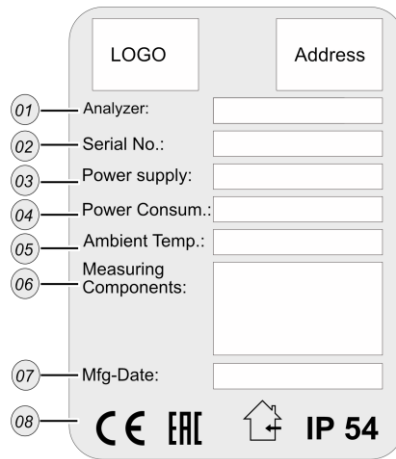

Number	Description
1	Product name
2	Serial number
3	Power supply
4	Electrical power
5	Permissible ambient temperature
6	Detectable sample gases and their measuring ranges
7	Manufacturer's date
8	Markings here as example

4 Device description

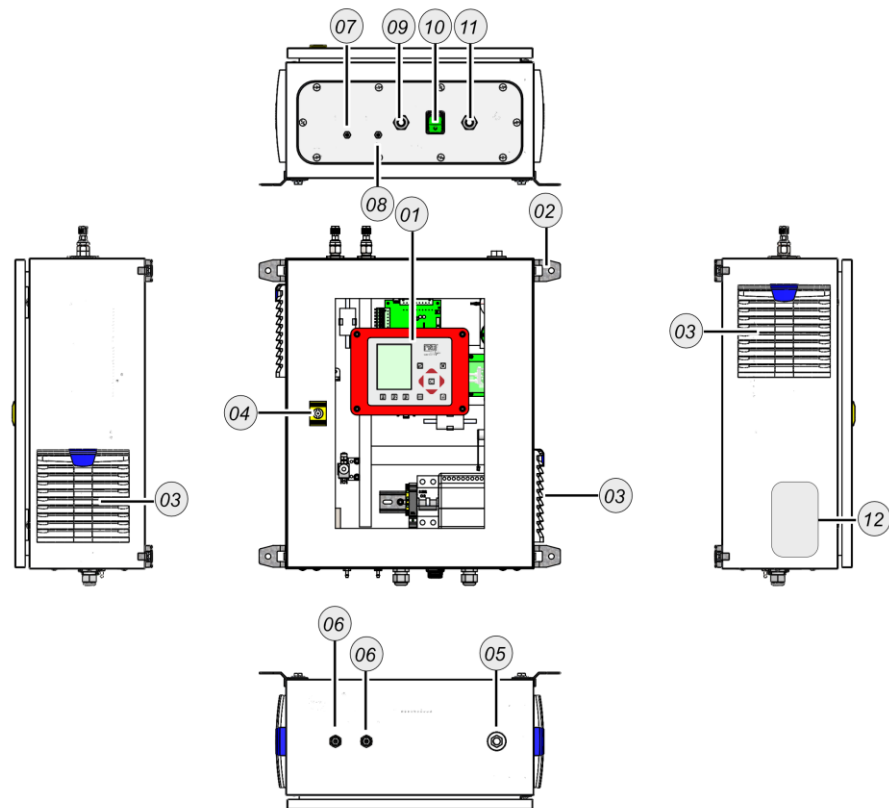

#	Description	#	Description
1	Operation unit	10	Power switch
2	Wall hanging	11	Gland for IO module
3	Filter-unit	12	Type plate
4	Lock		
5	Vent**		
6	Sample gas inlet*		
7	Condensate outlet***		
8	Zero gas inlet*** /Calibration gas inlet***		
9	Gland for power supply		

*The positions of the inlets and outlets are printed on the unit. All inlets and outlets have a G1/8 inner thread.

**The position of the vent is printed on the unit. The vent has a G1/4 inner thread.

***The positions of the inlets / outlets are printed on the unit. The inlets / outlets have a DN4/6 mm hose connector.

4.1 Operation unit

The control unit is used to operate the unit. In addition, the SD card slot is located on the back of the control unit.

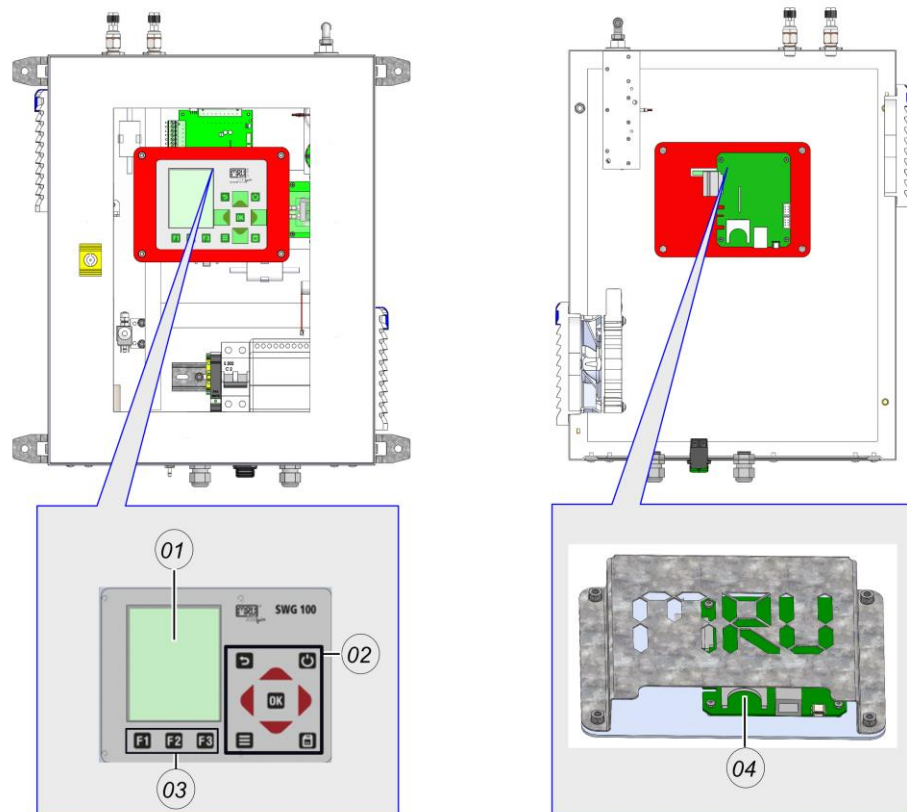

#	Description
1	TFT-Display
2	Control-keys
3	Function keys
5	SD-card slot.

5 Installation

You will learn how to assemble and install the device correctly. The installation work includes:

- Set up the device,
- Wire the unit electrically,
- Connect the tubing to the unit,
- Connect the sampling line.

5.1 General installation rules

For outdoor installation, mount the unit in a rain-protected and sun-protected location.

NOTE

If necessary, fit a rain and sun roof over the unit.

For indoor installation, mount the unit in a clean and dry place. Ensure that the room is constantly ventilated with fresh air.

Other general rules are:

- Mount the unit on a solid wall or steel beam.
- Make sure that the air circulation is not obstructed.
- Provide sufficient space for the piping.

5.2 Components and terms used

The components and the terms used are presented here. You will need these components for on-site installation.

#	Description	#	Description
1	DN4/6 mm Filter-nozzle unit	2	DN10/12 mm vent-fitting



5.3 Mounting the device

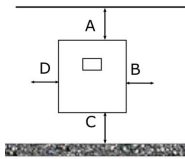

CAUTION

Risk from a net weight greater than 10 kg
 This may result in overloads or crush injuries.

- Move the measuring device with appropriate caution.

Your unit is designed as a wall-mounted housing. For installation, you must mount the wall-mounted enclosure on a stable wall using four M12 bolts (strength class: 8.8).

A suitable installation location must meet the following criteria:

- The installation location should be protected from direct sunlight.
- The installation site should be protected from direct rain.
- The installation site should be easily accessible.
- The installation site should be well ventilated.
- The installation site should have enough space for installation and operation.

ATTENTION

Keep attention to the minimum distance.

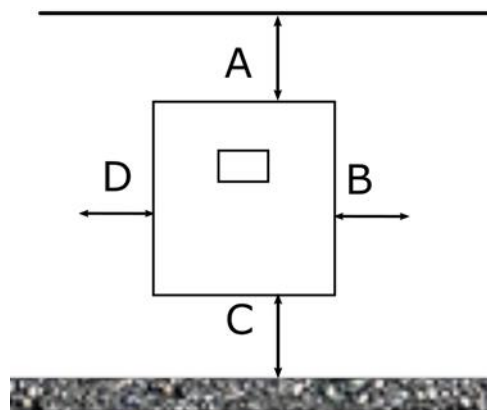

Position	Description
A	Min. 500 mm
B	Min. 300 mm
C	Min. 1000 mm
D	Min. 300 mm

5.3.1 Door distance

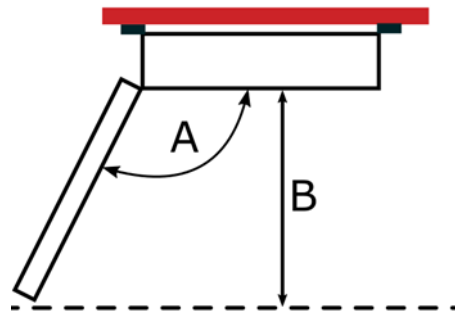

Position	Description
A	120°-180° depending on the type of device
B	Min. 1000 mm. Door hinges are on the right.

5.3.2 Dimensions and drilling plan

Wallmounting with:

- 4xM12 screws with strength class 8.8.
- 📄 See 11 / Appendix Seite 122

5.4 Connecting power supply

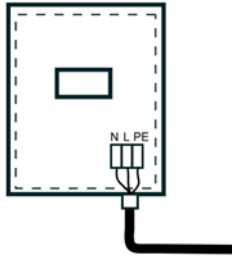

Connect the power supply to terminal block X-0.

This section tells you where to connect the power supply.

➔ See wiring diagram.

⚠ WARNING

Risk of serious damage to property and personal injury due to improper electrical installation.

Safe electrical installation can only be guaranteed if the person carrying out the installation has proven knowledge in the following areas:

- Connection to the installation network.
- Connection of several electrical appliances.
- Laying electrical cables.
- As a rule, only trained specialists in the field of electrical installation technology have this knowledge and experience. If these minimum requirements are not met or disregarded, you may be personally liable for damage to property or personal injury.

⚠ WARNING

Country-special electrical installation requirements

Find out about your country-specific requirements for additional electrical protection devices.

PREQUESTION

- A suitable 3-core installation cable with PE, L and N conductors, with a cross-section of 1.5 mm² must be available.
- The unit is designed for 100 - 230 VAC / 47 - 60 Hz.
- The terminal block for the voltage is marked X-0.

STEPS

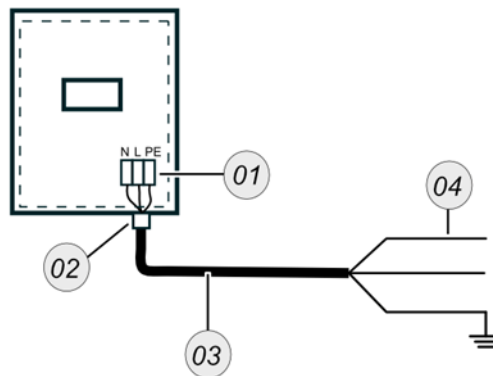

#	Description
1	Terminal block
2	Cable gland „Mains“
3	Core installation cable
4	Cable core L,N,PE

Fig.1

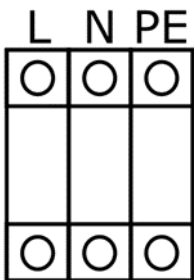

Terminal block X-0 for power supply.

- Route 3-wire installation cables through the "Main supply" cable gland (Fig.1 (2)).
- Find the terminal block X-0. On this block the 3-wire cable is installed (Fig1. (1)).
- Connect the PE conductor to the PE terminal.
- Connect the L conductor to the L terminal.
- Connect the N conductor to the N terminal.
- You have installed the power supply.

5.5 Connecting inputs and outputs

⚠ DANGER

Risk due to toxic gases

Noxious gases are sucked in by the measuring device and released into the ambient air.

- Only use the measuring device in well ventilated spaces.
- Always connect a hose to the vent.
- Always lead the hose into an area that is empty of people.

⚠ CAUTION

Acid from the condensate

Acid burns may result from weakly acidic liquids from the condensate.

- If you come into contact with acid, wash the area immediately using a lot of water.
- Note the safety data sheet for phosphoric acid (10%)

In this chapter you learn how to install and connect the right fittings on the different inputs and outputs.

REQUIRED COMPONENTS

- DN4/6 mm Filter-nozzle unit
- DN 10/12 mm vent fitting
- DN4/6 mm condensate fitting
- 1/8G zero gas-fitting
- 1/8G copper sealing
- Spanner with size: 16 mm

STEPS: INSTALL FITTINGS

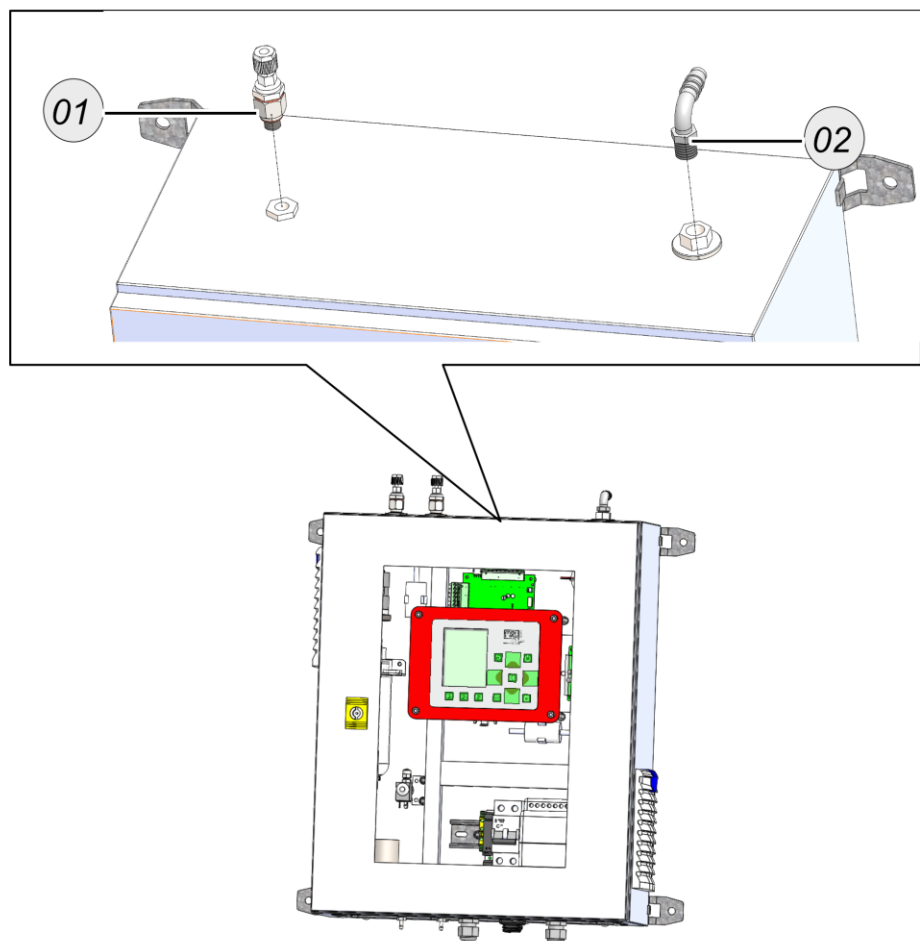

#	Description	#	Description
1	DN4/6 mm Filter-nozzle unit	2	DN10/12 mm vent fitting unit

Fig. 1

NOTE

Seal all threads with a PTFE tape.

- ▶ Screw the DN4/6 mm condensate connection hand-tight into the Condensate Inlet (Fig.1 (4)).
- ▶ Screw the DN4/6 mm zero gas-fitting hand-tight into the zero gas inlet (Fig. 1 (3)).
- ▶ Screw the DN10/12 mm vent connection hand-tight into the vent (Fig.1 (5)).
- ▶ Screw the DN4/6 mm Filter-nozzle unit into the calibration gas inlet and the sample gas inlets (Fig. 1 (1-2)). Use a spanner size: 16 mm.

✓ The fittings are mounted.

STEPS: CONNECT THE HOSES ON THE FITTINGS

ATTENTION – Acid from condensate. Acid burns may result from weakly acidic liquids from the condensate.

- ▶ Connect a DN4/6 mm hose to the condensate outlet and lead the hose into a condensate container.

▲ DANGER – Risk due to toxic gases. Noxious gases are sucked in by the measuring device and released into the ambient air.

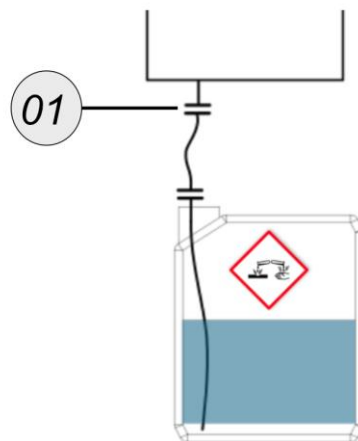

Fig. 2

- ▶ Connect a condensate canister to the condensate outlet (Fig. 2).

▲ CAUTION – Chemical burns from condensate Acid burns may result from weakly acidic liquids from the condensate.

- ✓ The vent is mounted.
- ✓ The condensate outlet is mounted.
- ✓ The sample gas inlet is mounted.
- ✓ The calibration gas inlet is mounted.

- ☞ Further steps: Install the calibration gas cylinders.
- ☞ Further steps: Install the tubing to the sample gas inlet.

5.6 Connect alarm-relay and RS-485



The RS-485-connection and the alarm-relay-connection are located on the main board.

The Alarm-Relay has the follow attitudes:

- Potential free relays.
- Max. 24 VDC
- Max. 1 Amp.

☞ See Modbus-protocol for more information about the Modbus-protocol.

i It is a Modbus-RTU protocol.

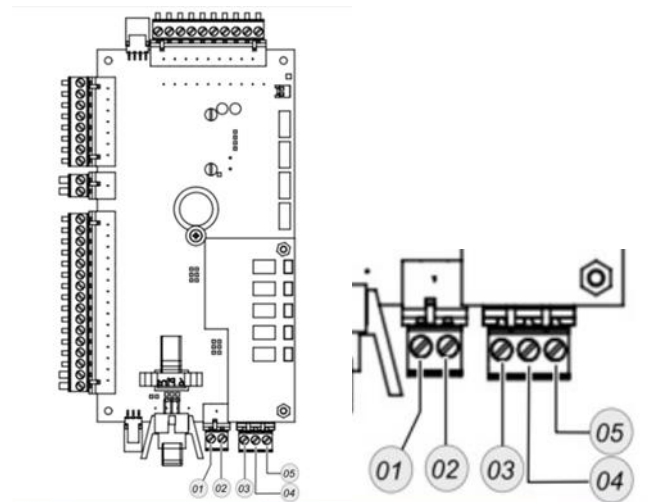

#	Connector	Description
1	Alarm connector	Alarm connector 1
2	Alarm connector	Alarm connector 2
3	RS-485	GND
4	RS-485	B_EXT-
5	RS-485	A_EXT+

STEPS:

▶ Connect the wires on the described connectors.

✓ The alarm-relays and RS-485 is connected.

5.7 Switching on the unit

Here you will find out to switch on the main switch.

STEPS:

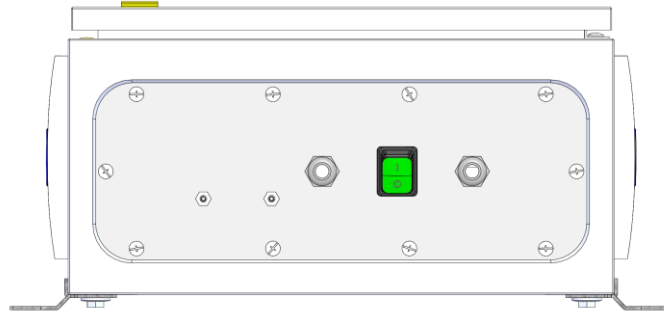

Fig. 1

- ▶ Turn the main switch to the "ON" position (Fig.1).

The boot process is started. The boot process takes about 15 seconds.

Self test - MRU SWG100 SynGas	
MGB CO2,CO,CH4	OK
ESM (O2-PM)	Warm-Up
ESM (H2-TCD)	Warm-Up
Gascooler module	OK
Valve control module	OK
Cond. pump module	OK
Fan control module	Warm-Up
T-sensor 25.2°C	OK
T-gascooler 4.8°C	OK

Fig. 2

The self-test is started (Fig. 2).

- ▶ Wait until the self-test is finished. Dependent from the options this may take longer.

NOTE

After the self-test is finished, the device makes the follow steps automatically.

Air purging 4:48	
CH4	---
[%]	---
O2	---
[%]	---
CO2	---
[%]	---
H2	---
[%]	---
CO	---
[%]	---
Balance N2	---
[%]	---
storage extras	

Fig. 3

The main measurement window appears. The grey background means that the measurement mode is not active (Fig. 3).

The first zero point measurement is started.

- ▶ Wait until the unit has completed the first purging phase and zeroing. This process takes about 5 minutes.

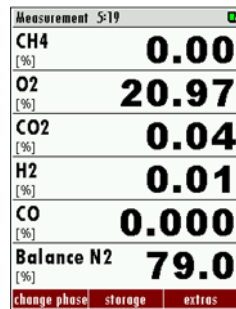

Measurement 5:19	
CH4 [%]	0.00
O2 [%]	20.97
CO2 [%]	0.04
H2 [%]	0.01
CO [%]	0.000
Balance N2 [%]	79.0
change phase storage extras	

Fig. 4

The unit goes into measuring mode. You can recognise this by the white background (Fig. 4).

- ✓ The unit is ready to measure.

6 Operation





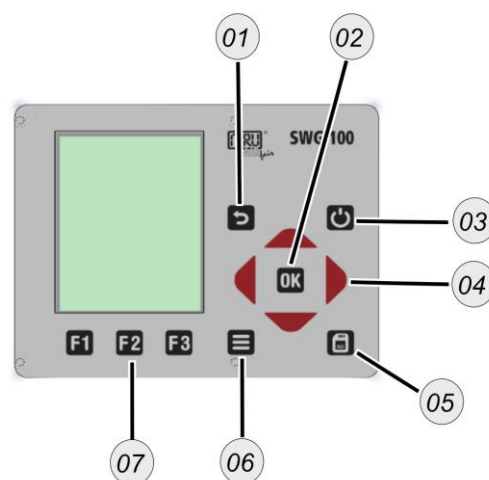

In this chapter you will learn how to operate the unit and make different settings.

It deals in particular with:

- The operation of the unit,
- The measuring menu structure,
- The menu navigation and the setting options.

6.1 Operating and display elements



#	Symbols	Description
1		ESC: abort or return to the menu above
2		OK: confirmation key, select a marked menu point.
3		Prepare Power-Down: Press this key before you disconnect mains. The device will store changed user settings and other operational data and will purge the sensors
4		Arrow keys: context dependent functions, e.g. scroll in between lines, change values, change view.
5		Screen shot: press this key in order to store a screen shot of the current display contents onto the SD card.
6		Menu key: Will show all available functions in the window that is currently in use – also those which have an individual key on the key pad like the printer and the three function keys.
7		Function Keys: Activates the functions seen on the display (2 function key bar)

6.2 Menu structure

After switching on, the unit is in the measuring menu.

- Press the function key **F2** to access the "STORAGE MENU".
- Press the function key **F3** to access the "EXTRAS MENU".

Here you can see the general menu structure.

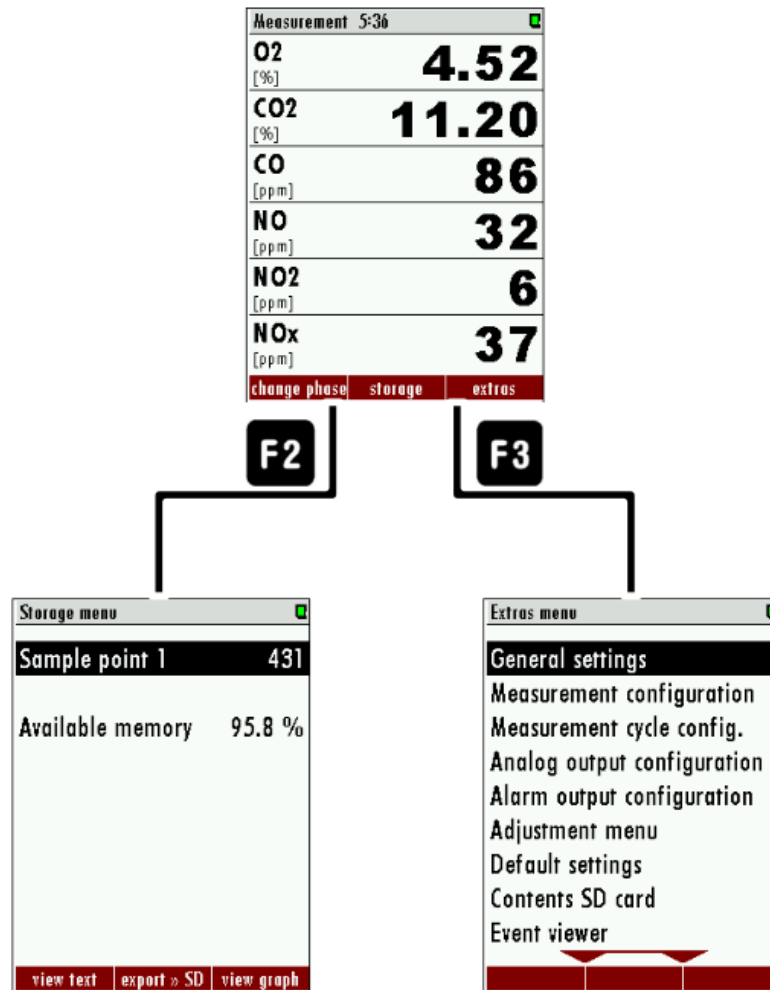

6.2.1 Measuring menu structure

Here you can see the structure of the measuring menu.

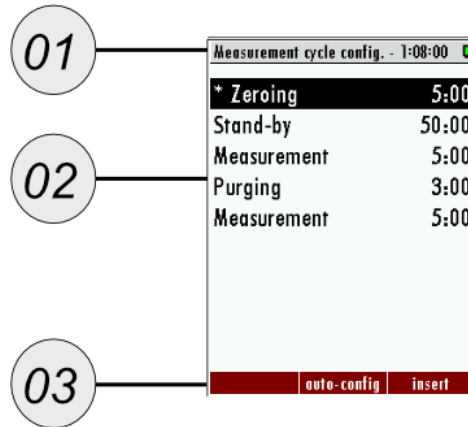

#	Description
1	Menu bar
2	Display field
3	Function bar

6.2.2 Open submenu

Each menu item has a submenu. The submenu may contain additional functions.

STEPS

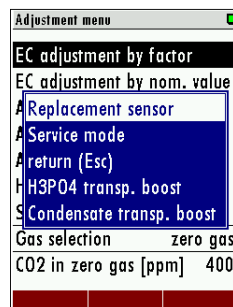

- ▶ Open the menu item you are interested in.

In this example, the menu "ADJUSTMENT MENU". You will find the menu under the path: EXTRAS / ADJUSTMENT MENU.

- ▶ Press the menu key .

A blue window opens with further menu items. The blue window is the submenu.

- ✓ You have called up the submenu.

6.3 Setting options Measuring menu

You can perform the following actions in the measurement window.

- Change the display mode: Zoom / Standard
- Change measurement page.
- Display last measurement point values
- Individual configuration of the measurement window content.

6.3.1 Switch to Zoom/Standard display mode

STEPS

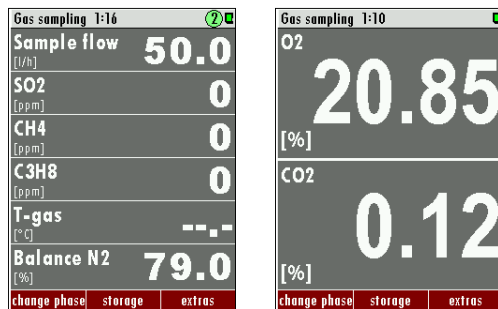

- ▶ Press the **menu button**  in the measurement window.

Submenu opens.

- ▶ Select between zoom view and standard view.

- ✓ The view is selected.

NOTE

For units with only one measuring point, switching is also possible with the *up/down arrow keys* (**↑** / **↓**).

6.3.2 Change measurement page

STEPS

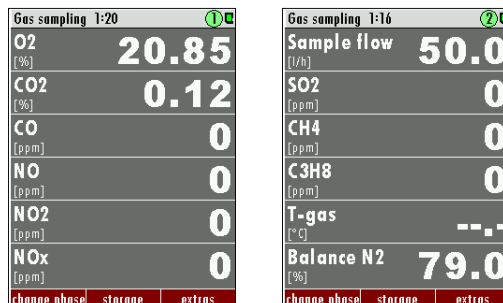

- ▶ Press the **right/left arrow key** (**←** / **→**).

- ✓ The page is changed. The page number is displayed in the title bar.

6.3.3 Displaying the last Measuring Point Values

You can display the last values of the measuring points that are not active.

PREREQUISITE

- Your unit has several measuring points.
- i** You do not interrupt the active measurement. However, you can view the last values of the last measuring points. This has no influence on the currently active measurement.

STEPS



- Press the *upper/lower arrow keys* (↔).
- In the menu you will see the values of the next measuring point.

6.3.4 Configuring the Measurement Window

You can change the order of the displayed measurement values in the measurement window.

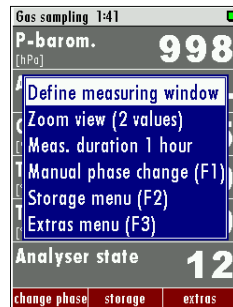
STEPS



- ▶ Press the **menu key**  in the measurement window.
The **blue submenu** appears.
- ▶ Select "DEFINE MEASUREMENT WINDOW".
The measurement window is active again.
- ▶ Mark the position to be changed with the **up/down arrow keys** (/↓).
- ▶ Select the desired display value with the **left/right arrow key** (←/→).
- ▶ Press the **OK-key** to confirm the display value.
The selected display value appears in the desired position.
- ▶ Confirm the change.
- ✓ The display value in the measurement window is adjusted.
- ✓ Repeat the procedure if desired.

NOTE

With the function "Measurement window autoconfiguration" in the context menu, the measuring device can also make an adjustment independently, which is usually useful.

6.4 Menu: Extras

6.4.1 General settings

General settings	
LCD brightness	60 %
Country	England
Language	English
Keyboard beep	ON
Request admin-PIN	OFF
Service message	OFF
External control	OFF
Thresh.cond.alarm [kΩ]	50
Storage interval	1/m.phase
date & time	modbus

Menu path: EXTRAS / GENERAL SETTINGS.

Setting	Operation	Setting options
LCD Brightness	Arrow keys (←→)	20%...100%
Country	Arrow keys (←→)	Several
Language	Arrow keys (←→)	Several
Key signal	Arrow keys (←→)	ON / OFF
PIN query	Arrow keys (←→)	ON / OFF
Service message	Arrow keys (←→)	ON / OFF
External control	Arrow keys (←→)	Several
Condensate threshold	Arrow keys (←→)	20...100
Gas cooler	Arrow keys (←→)	5...15°C
Date & Time	Function key F1	
Modbus	Function key F3	Several

☞ For Date & Time see chapter: 6.4.9 Set Date & Time.

☞ For Modbus see chapter: 6.4.8 Set the Modbus.

6.4.2 Measurement configuration

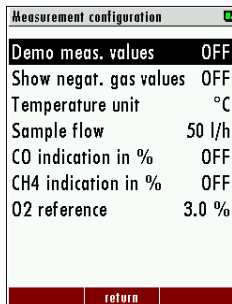

i Menu path: EXTRAS / MEASUREMENT CONFIGURATION.

In this menu you can set the temperature unit used and the volume flow.

Settings	Operation	
Temperature unit	Arrow keys (←→)	°C / F
Sample flow	Arrow keys (←→)	30...70 l/h

6.4.3 Adjustment menu

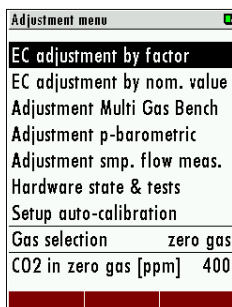

i Menu path: EXTRAS / ADJUSTMENT MENU.

In this chapter you will find all possible adjustment options. You will also find a Hardware Status & Tests menu here.

NOTE

The operation of the individual adjustment menus can be found in the respective measurement technology chapters.

6.4.4 Factory settings

ATTENTION

All saved settings are lost here.

i Menu path: EXTRAS / FACTORY SETTINGS.

This menu item allows you to reset all settings to the factory settings.

6.4.5 Contents SD card

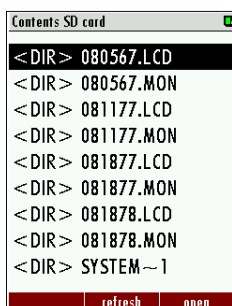

i Menu path: EXTRAS / CONTENTS SD CARD.

This menu item shows you the contents of your SD card.

6.4.6 Event viewer

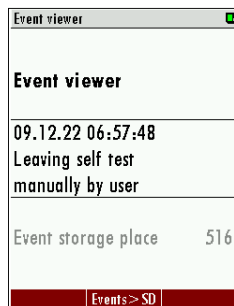

 Menu path: EXTRAS / EVENT VIEWER.

In this menu, you can view various events, such as times of zeroing or error messages.

6.4.7 Device Info

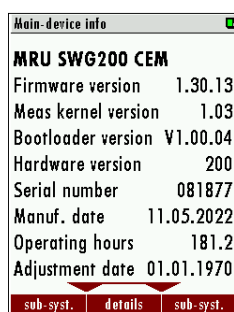

 Menu path: EXTRAS / INFO MAIN DEVICE.

In this menu you get general information about your unit. You can also update the various built-in modules here.

6.4.8 Set the Modbus

STEPS

General settings	Modbus slave settings
LCD brightness 60 %	Port selection 1
Country England	Baud rate 19200
Language English	Slave address 238
Keyboard beep ON	Stop bits 1
Request admin-PIN OFF	Parity even
Service message OFF	Data bits 8
External control OFF	Invalid value -1E38 (MRU)
Thresh.cond.alarm [kΩ] 50	Response delay [ms] 6
Storage interval 1/m.phase	Request count 0

date & time modbus **F3** default Start test user list

▶ Open the menu: Modbus: EXTRAS / GENERAL SETTINGS → **F3**.

The menu window Modbus Slave Settings opens.

▶ Set the required baud rate, slave address and parity / stop bits.

▶ Exit the menu.

▶ Confirm the saving.

✓ The Modbus settings have been made.

6.4.9 Set Date & Time

The unit automatically saves measured values including a time stamp. Therefore, the system clock of the unit should be set correctly.

STEPS

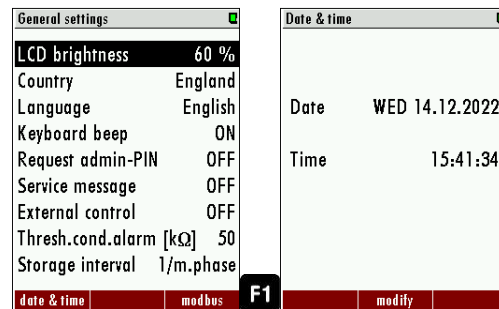

▶ Open the menu: Set date & time: EXTRAS / GENERAL SETTINGS → **F1**.

The menu window **SET DATE & TIME** opens.

▶ Set the date and time. Press the **F2**-key.

▶ Exit the menu.

▶ Confirm the saving.

✓ The date and time are set.

6.4.10 Menu: Data-store

Data storage	<p>The measured values are stored internally in the unit.</p> <ul style="list-style-type: none">• The unit can store up to 20 000 readings.• The unit stores the current measured values at the end of the measuring cycle for each measuring point.• As soon as the memory space is full, the unit overwrites the oldest measured values (ring memory principle).
Special features	<p>You can equip the unit with an SD card. We recommend that you do this. The unit has a data storage strategy:</p> <ul style="list-style-type: none">• If memory usage is 99%, the oldest 20% of the measurements are automatically saved to an SD card in CSV format and then deleted from the memory in the device.• If the export to the SD card fails (SD card is missing or write-protected), only 4 % of the old measurements are deleted. The file name shows the date of the last measurement exported in the file e.g. "20141031.csv".

NOTE

Example:

A device with 2 measuring points and a configured measuring cycle of 32 minutes stores $2 * 24 * 60/32 = 90$ measurements per day (45 per measuring point). The ring buffer provides capacity for measurements of $20000/90 = 222$ days (more than 7 months).

6.4.11 Calling up the data memory menu

In the memory menu, you can view your saved data:

- View
- Export
- Transfer to other data formats.

STEPS

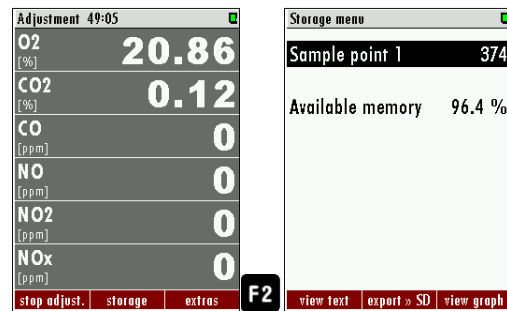

- ▶ Go to the MEASUREMENT WINDOW.
- ▶ Press the **F2**-key in the measurement window.
- ✓ You are in the DATA MEMORY MENU.

6.5 Displaying stored values in text mode

To read stored measurements in text mode, proceed as follows:

STEPS

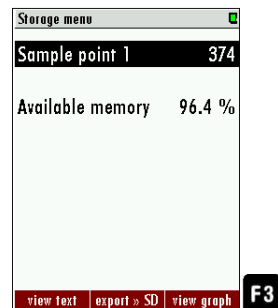

- ▶ Enter the DATA MEMORY MENU.
- ▶ Press the **F1**-key = „VIEW TEXT“.

The last stored measurement is displayed.

- ▶ Navigate through the measurements with the *right/left-keys* until you find your measurement.

NOTE

You can use the **F3**-key to go to the last measurement.
You can navigate further with the steps above.

- ✓ You can continue navigating with the steps above.

6.5.1 Displaying stored values in graphic mode

To read stored measurements in text mode, proceed as follows:

STEPS

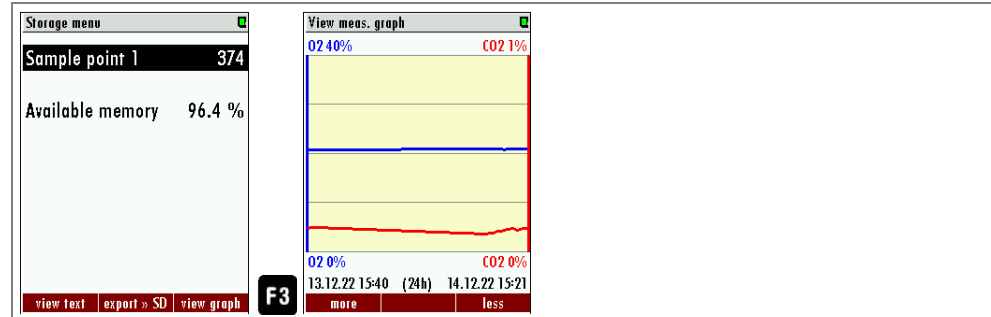

- ▶ Enter the DATA MEMORY MENU.
- ▶ Press the **F3**-key = "VIEW GRAPHIC".

The last stored measurement is displayed.

- ▶ Navigate through the measurements with the *right/left-keys* until you find your measurement.

NOTE

You can use the **F3**-key to go to the last measurement.
 You can navigate further with the steps above.

- ✓ You can continue navigating with the steps above.

6.5.2 Export measurement to SD card

You can export your measurements as a CSV file to an SD card.

PREREQUISITE

- ✓ An SD card is in the unit.
- ✓ The SD card must not be write-protected.

NOTE

The CSV format is country-specific. The respective valid CSV format is set via the "General settings" menu.

- ▶ Call up the DATA MEMORY MENU.
- ▶ Press **F2**-key = "EXPORT >> SD".

The CSV files are written to the SD card. When the process is completed successfully, a message appears.

- ✓ The data is saved as CSV format on the SD card.

6.5.3 Setting the CSV format

You can set the CSV format directly on the unit.

Steps

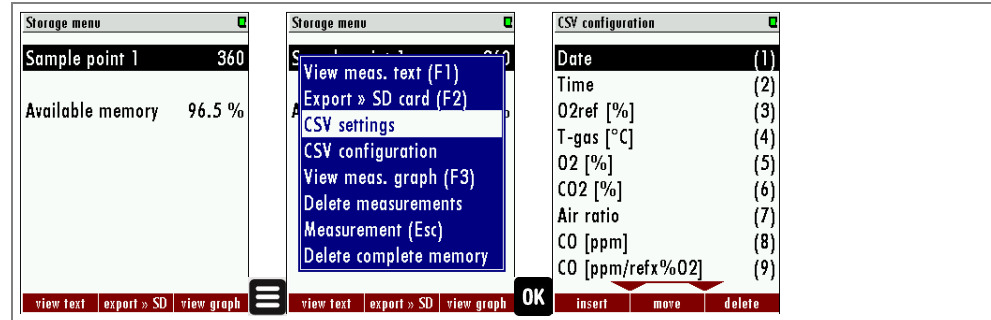

▶ Call up the DATA MEMORY MENU.

▶ Press the *menu key* .

The SUBMENU opens.

▶ Open the CSV SETTINGS menu item.

The CSV SETTINGS menu opens (see picture below).

▶ Set your individual settings here.

▶ Exit the menu.

▶ Confirm the saving.

✓ The CSV settings are changed.

7 Setting the measuring cycle

You have the possibility to configure an individual measuring cycle.

There are the phases:

- Zeroing.
- Flush.
- Quiet mode.
- Measurement SP. x (SP.x stands for measurement point 1, 2).

7.1 Menu path and basic structure

Menu path: EXTRAS / CONFIGURATION MEASUREMENT CYCLE.

In this menu you can see the currently active measuring cycle of your unit.

The illustration below and the table show the meaning of the individual sections.

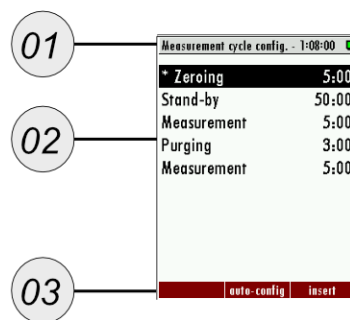

#	Description
1	Duration until end of measuring cycle
2	Measuring cycle list
3	Function keys

7.1.1 Navigating in the menu

You can set each phase individually. To do this, you must call up the phase submenu.

STEPS

- ▶ Select your desired phase with the *up/down arrow key*.
- ▶ Press the **OK**-key.

The phase submenu for the phase appears. In the example below for taking the zero point.

- You can make individual settings here. See the following chapters.

7.1.2 Delete Phase

STEPS

- ▶ Use the up/down arrow keys to select the phase to be deleted.
- ▶ Press the **function key** **F1** to delete the phase.
- ✓ You have deleted the phase.

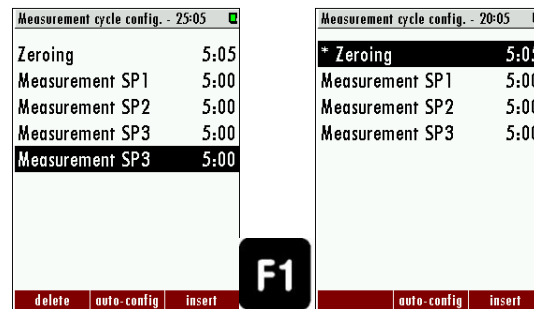

7.1.3 Insert phase

STEPS

- ▶ Press the **function key** **F3**.
- ▶ A new phase appears.
- ▶ Press the **left/right arrow key** to select your desired phase.
- ✓ You have inserted a new phase.

7.1.4 Insert Autoconfiguration

Two standard cycles are stored. You can insert the cycles via **AUTO CONFIG.**

STEPS

NOTE

The autoconfigurations only contain measurements and zero point measurements. Other phases are deleted.

- ▶ Press the **function key** **F2**.
A zero point measurement is inserted at the beginning of the measurement cycle.
- ▶ Press the **function key** **F2** again.
One zero-point reading per measurement is inserted.
- ▶ Select the standard that is reasonable for your measurement application.

Measurement cycle config. - 20:05		Measurement cycle config. - 30:00	
* Zeroing	5:05	Zeroing	5:00
Measurement SP1	5:00	Measurement SP1	5:00
Measurement SP2	5:00	Zeroing	5:00
Measurement SP3	5:00	Measurement SP2	5:00
		Zeroing	5:00
		Measurement SP3	5:00
auto-config insert		auto-config insert	

The two auto configurations in comparison.

7.2 Phase submenus: Setting options

Here you can find out which settings are possible in the phase submenus.

7.2.1 Zeroing (Cycle Phase Details)

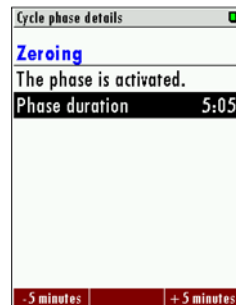

In the menu, the details of the cycle phase for zeroing can be viewed and, if necessary, changed.

Zeroing	
Measuring valve	Closed
Zeroing valve	Open
Duration	2 min to 24 h

7.2.2 Measurement SP.x (Cycle Phase Details)

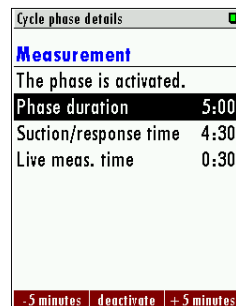

In the cycle phase details, the measuring time and the sampling time can be changed. Each individual measuring point can be adjusted individually.

Measurement SP.x	
Measuring valve	Measuring valve of the current measuring point is open, all others are closed
Zeroing valve	Closed
Duration	2 min to 24 h

7.2.3 Stand by (cycle Phase details)

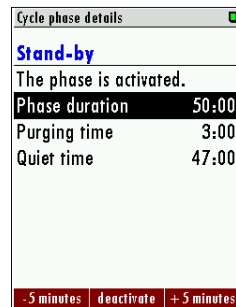

Within this cycle phase, the flushing time and the idle time can be set.

- Duration of the phase: Total idle time.
- Purge time: Purging of the unit with ambient air through the zero gas inlet.
- Sleep time: The time the unit is in sleep mode.

Stand by	
Measuring valve	Closed
Zero valve	Closed
Duration	2 min to 24 h
Flushing time	30 sec. to 1 h
Rest time	calculated

7.2.4 Purging (Cycle Phase Details)

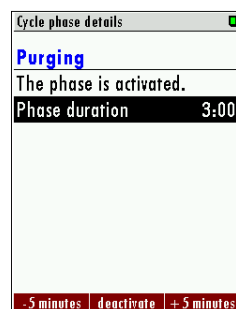

Purging is a separate configuration item for purging the unit with ambient air and thus removing foreign gas from the lines and the measuring equipment. This may be necessary when switching between different measuring points that have different gases or gas concentrations.

Purging	
Measuring valve	Closed
Zero valve	open
Duration	2 min to 24 h

7.3 Example for a measurement cycle configuration

In this chapter, an individual and fictitious measurement cycle is created. The measurement cycle should have the following sequence:

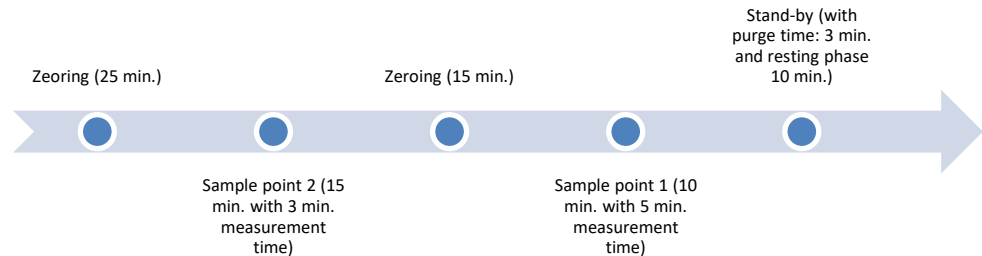

EXAMPLE-STEPS



- ▶ Open the path: EXTRAS / CONFIGURATION MEASURING CYCLE.

The standard measuring cycle appears.

- ▶ Insert a zero-point measurement.

- ▶ Press the **OK** key.

The phase submenu opens.

- ▶ Set the zeroing to 25 min.

The zero point measurement has been set to 25 min.

- ▶ Go back to the configuration measuring cycle menu.

- ▶ Insert the measurement SP.2.

- ▶ Open the phase submenu of measurement SP.2.

- ▶ Change the settings.

- ▶ Proceed in the same way with the items measurement SP.1 and the idle state.

- ✓ The measurement cycle is set.

7.4 Cycles-Timer: Interception of Events

The cycle timer is used to capture an event from the measurement phase. In doing so, the resting phases or zero point measurements are set in such a way that the event always falls within the measuring phase. An event can be, for example, the start-up of a system.

The cycle timer is characterized by the following:

- Has priority over the normal set measurement cycle.
- Is deactivated in the default setting.

7.4.1 Calling up the cycle timer

The cycle timer menu is called up as follow:

1. 1st menu path: Extras / Configuration Measuring cycle / Context menu / Cycle timer.

The menu window „Cycle Timer“ appears.



Abb. 1:

7.4.2 1.1.2 Menu structure

The menu is structured as follows:

1. 1st measuring phase...ends at: Set when the 1st measuring phase ends. After the measuring phase, a zero point is taken.
2. Interval for: Longer of the further measuring phases. After the measuring phase there is a zero point reading.
3. Alternative end times: Display of the following measurement phase starts.
4. Time: Shows the current time.

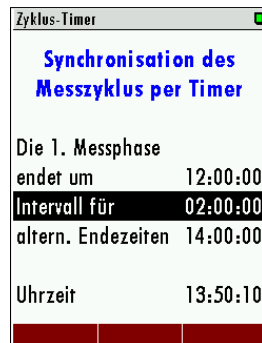

Fig. 2: In the example shown, the measurement phase always ends at 12 o'clock, 2 o'clock, 4 o'clock, 6 o'clock, 8 o'clock, 10 o'clock, 0 o'clock, 2 o'clock, 4 o'clock, 6 o'clock, 8 o'clock or 10 o'clock. This means that the zero point measurements (except the first one after power-on) are always started at these times.

NOTE

The interval should be chosen so that the total cycle time is a multiple of it (in the example this is so $2\text{ h} * 4 = 8\text{ h}$).

7.4.3 Setting the cycle timer (example)

A measuring system consists of 3 units. The measuring cycle of the units is to be set so that the system is permanently monitored and the zero point measurements do not overlap. The 3rd unit serves as failure protection. This can be achieved, for example, by the following setting:

Unit	1st ending of phase	Interval
A	11:20	2 h
B	12:00	2 h
C	12:40	2 h

Tab. 1:

Without the cycle timer, all 3 units would run synchronously in the event of a power failure until the 1st zero point measurement is completed. Only then would the configured cycle start to run.

In the event of a power failure at 1 p.m., this means that all 3 units perform the self-test at the same time, the zeroing and the 1st measuring phase run synchronously. The 1st measuring phase would be finished at 20:50.

By activating the cycle timer, the following offset would be possible:

Unit	1st ending of phase	2nd zero phase begins at...
A	21:20	21:20
B	20:00	20:00
C	20:40	20:40

Tab. 2:

7.5 Update software

If necessary, the analyser and the various installed options can be updated. The following options are affected:

- The firmware of the analyser.
- The firmware of the main board.
- The firmware of the NDIR cuvette.
- The firmware for the I/O modules.

7.5.1 Overview: Possible system updates

To distinguish the individual firmware updates of the modules, they have typical file names. This always consists of a 4-digit number and an abbreviation of the respective module. The file attachment is always ".fwb".

NOTE

For example, a firmware update could have the following name: xxxxiom.fwb. The number depends on the unit family.

The table below shows the possible firmware names.

Module	Firmware name
Main unit	xxxx.fwb
Main board	xxxxmb.fwb
IO module	xxxxiom.fwb
NDIR cuvette	xxxxndir.fwb

7.5.2 Updating the main unit

STEPS

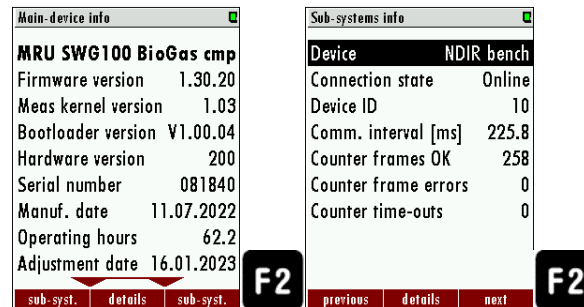

To update the main unit, proceed as follows.

- ▶ Copy the firmware directly to an SD card. Make sure that the firmware is copied in the main menu.
- ▶ Insert the SD card into the SD card reader of the unit. This is located behind the control unit.

The unit emits a sound.
- ▶ Open the menu "EXTRAS / DEVICE INFO".

The menu "Details main unit" appears.
- ▶ Press **F2** = Details.

The unit info window appears.
- ▶ Press **F2** = FW update
- ✓ The update is carried out. The unit restarts.

7.5.3 Updating the different modules

In addition to the main unit, the individual BUS modules can also be updated. Proceed as follows.

STEPS

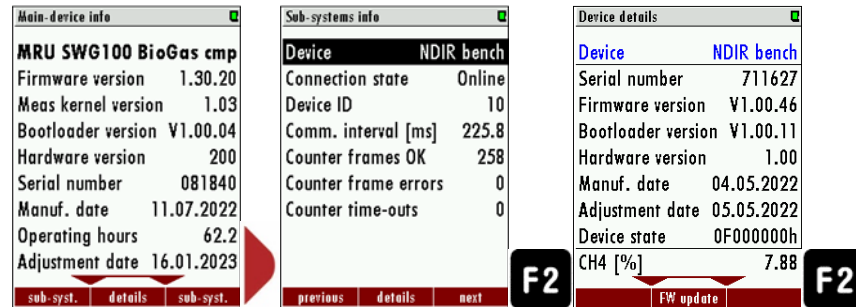

- ▶ Copy the firmware directly to an SD card. Make sure that the firmware is copied in the main menu.

- ▶ Insert the SD card into the SD card reader of the unit. This is located behind the control unit.

The unit emits a sound.

- ▶ Open the menu "EXTRAS / DEVICE INFO".

- ▶ Press the *left/right arrow key*.

The menu "INFO SUB.-SYSTEM" menu appears.

- ▶ Select the menu item "DEVICE".

- ▶ Change to the respective module with the left / right arrow key.

- ▶ Press **F2** = DETAILS.

The menu "Device details" appears.

- ▶ Press **F2** = FW UPDATE.

- ✓ The update is carried out. The unit restarts in the process.

8 Option

8.1 Option: IO module

IO modules are the interface for signal transmissions, remote control and for reading signals from transmitters.

IO modules have the following features:

- Transmission of measurement signals, through four separate 4-20 mA outputs,
- Two alarm outputs,
- One PT-1000 input,
- One thermocouple input (type: K),
- Four inputs, for standard 4-20 mA transmitters (2-wire, 3-wire, 4-wire) with an extra power supply.
- Two inputs, for voltage transducers.
- Remote control function for the analyser.

8.1.1 IO module position

Optionally, an device can be equipped with IO modules (max.: 10 pieces).
The IO modules are located on the top-hat rail.

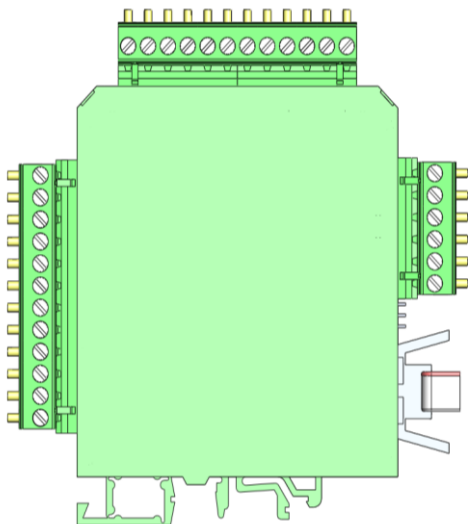

8.1.2 Pin assignment

The following pin assignment diagram shows where the different pins, with their respective functions, can be found and which pins have a double assignment.

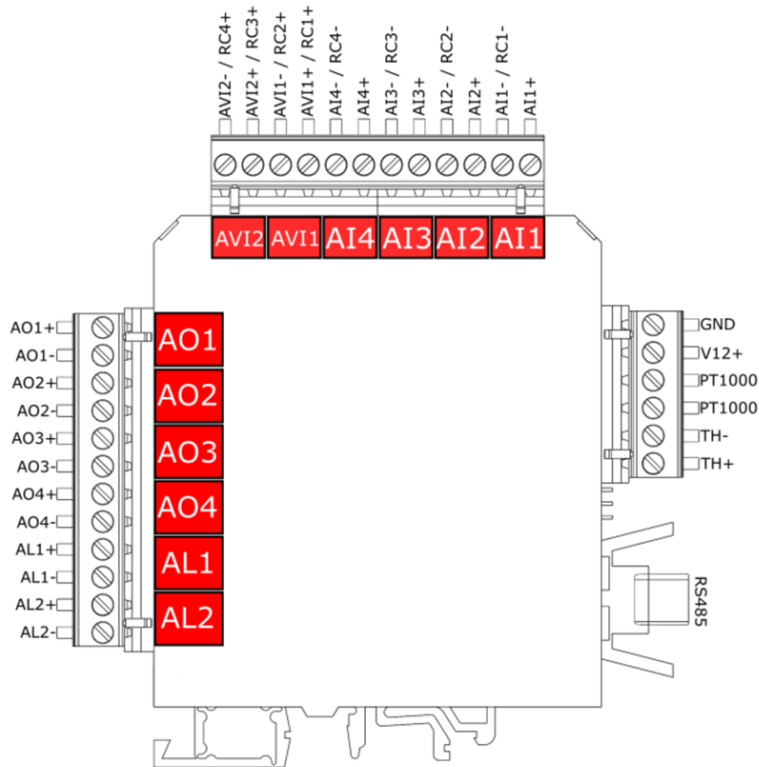

Pin assignment of IO modul

The table shows the assignment of the respective individual pins.

Description	Abkürzung	PINs	Max. externe Spannung	Bürde	Messwiderstand	Doppeltbelegung
Analoge-Ausgänge 4-20 mA	AO1	AO1+ / AO1-	--	500R	--	Nein
	AO2	AO2+ / AO2-	--	500R	--	Nein
	AO3	AO3+ / AO3-	--	500R	--	Nein
	AO4	AO4+ / AO4-	--	500R	--	Nein
Alarmausgänge	AL1	AL1+ / AL1-	24 VDC	500R	--	Nein
	AL2	AL2+ / AL2-	24 VDC	500R	--	Nein
Analoge Eingänge 4-20 mA	PWROUT	V12+ / GND	--	--	--	Nein
	AI1	AI1+ / AI1-	--	--	50R	AI1- = RC1-
	AI2	AI2+ / AI2-	--	--	50R	AI2- = RC2-
	AI3	AI3+ / AI3-	--	--	50R	AI3- = RC3-
	AI4	AI4+ / AI4-	--	--	50R	AI4- = RC4-
Fernbedienung	RC1	RC1+ / RC1-	--	--	--	RC1- = AI1-
	RC2	RC2+ / RC2-	--	--	--	RC2- = AI2-
	RC3	RC3+ / RC3-	--	--	--	RC3- = AI3-
	RC4	RC4+ / RC4-	--	--	--	RC4- = AI4-
Analoge Eingänge 0-10 V	AVI1	AVI1+ / AVI1-	--	--	--	JMP1_out = AVI1+ JMP2_out = AVI1-
	AVI2	AVI2+ / AVI2-	--	--	--	JMP3_out = AVI2+ JMP4_out = AVI2-

8.1.3 Analogue outputs 4-20 mA (AO1-AO4)

Installation/Connection

🔗 Assignment: See 1.1.2 Pin assignment

Setting up analogue output

You can set up to 4 analogue outputs per IO module.

Precondition: The IO module option is installed.

- ▶ Open the path "EXTRAS / CONFIGURAT. ANALOGUE OUTPUTS" path.
- ▶ Select the respective IO output and confirm with "DETAILS".

The setting window of the IO output appears.



Selection window: MS1 = measuring point 1 , I/O 1/1 = first IO module at the first 4-20 mA output.

- ▶ Select the measuring point and the measured variable.
- ▶ Apply the minimum (4 mA) and maximum (20 mA) for the measured variable.

The analogue output is now configured.

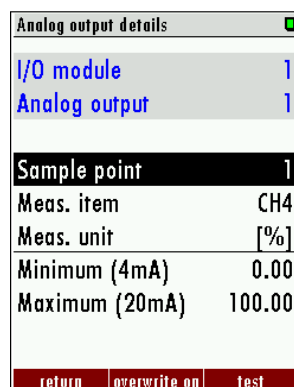

Setting the measuring point, the measured variable and the range for a 4-20 mA output.

8.1.4 Alarm Output Setting (AL1-AL2)

Installation/Connection

📄 Assignment: See 8.1.2 Pin assignment.

Setting the alarm output

You can set up 2 alarm outputs per IO module.

Precondition: The IO module option is installed.

- ▶ Open the path "EXTRAS / CONFIGURAT. Open the path "EXTRAS / CONFIGURE ALARM OUTPUTS".
- ▶ Select the respective alarm output and confirm with "Details".

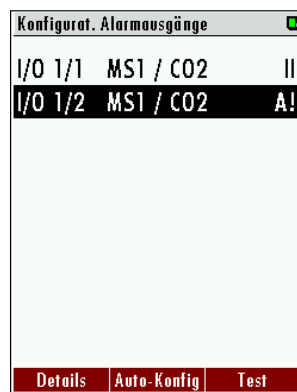

Selection window: MS1 = measuring point 1, I/O 1/1 = first IO module at the first alarm output.

The setting window of the alarm output appears

- ▶ Select the measuring point and the measured variable here.
- ▶ Enter the limit value.

Under "Alarm if value..." you can set whether the alarm is triggered below the limit value or when the limit value is exceeded.

- ▶ Under "If value invalid" you can set whether an alarm is triggered or the unit switches off.

The alarm output is now configured.

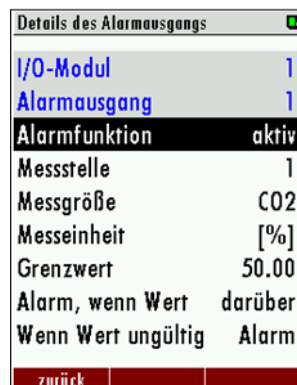

Setting the measuring point, the measured variable, the limit value and the alarm side (exceeding or falling below).

8.1.5 AUX input for transmitter (AI1-AI4)

📄 Assignment: See 8.1.2 Pin assignment

The following 4-20 mA transmitters can be read in at the AUX inputs:

- 2-wire
- 3-wire
- 4-wire.

The IO module has a separate 12V power supply for the connected transmitters.

AUX input: Technical data

- Measuring resistor: 50 Ohm
- Power supply: 12 VDC / 200 mA

Connection: 2-wire transmitter

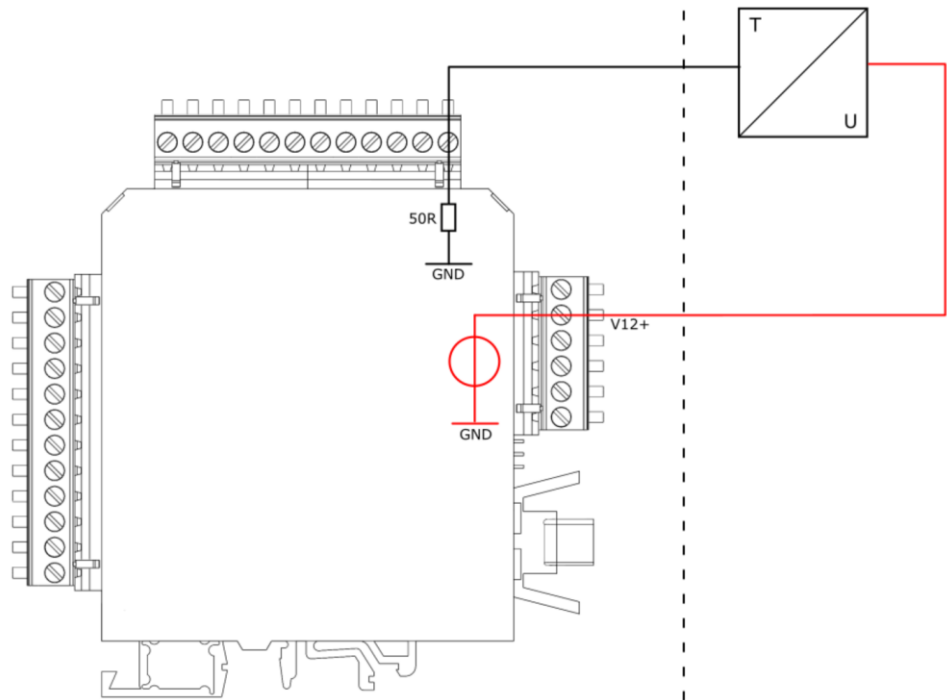

2-wire transmitter, connected to the 12 VDC of the IO module.

Connection: 4-wire transmitter

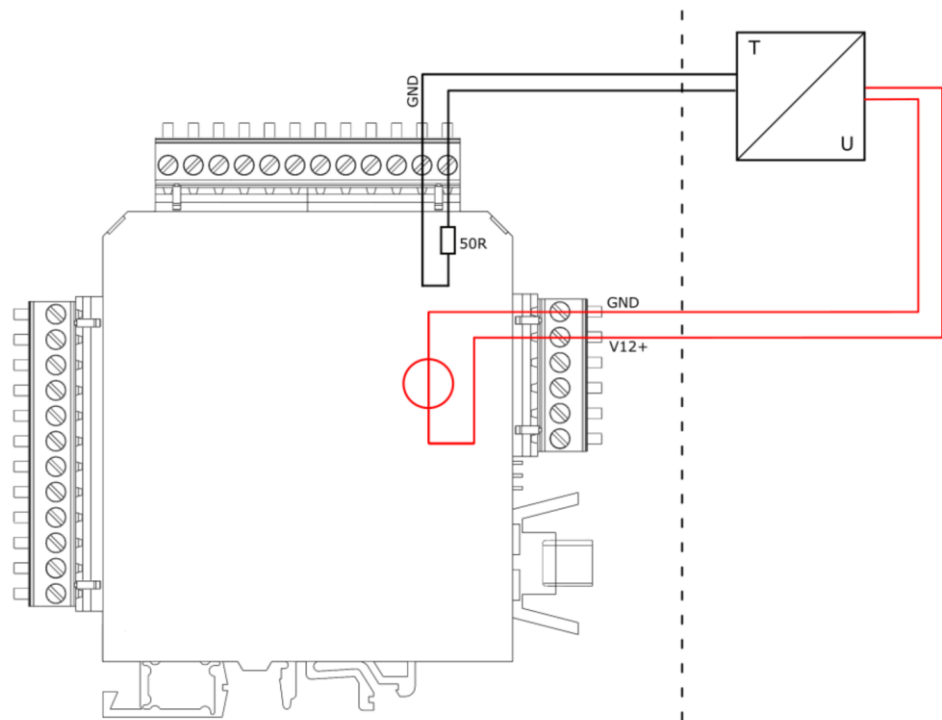

4-wire transmitter, connected to the 12 VDC supply of the IO module.

8.1.6 Set up AUX input

You can assign 4 AUX inputs per IO module.

Precondition: An IO module is installed.

- ▶ Open the path "EXTRAS / CONFIGURATION AUX INPUTS".
- ▶ Select and activate the respective AUX input.

Details des AUX-Eingangs		Konfiguration AUX-Eingänge	
I/O-Modul	1	I/O 1/1	AUS
AUX-Eingang	1	I/O 1/2	AUS
		I/O 1/3	AUS
Messgröße	AUS	I/O 1/4	AUS

AN Details Auto-Konfig

Selection window example: I/O 1/1 = first IO module at the first AUX input.

The setting window of the AUX input appears.

- ▶ In this window, the measured variable can be selected. In addition, an individual AUX input can be created under "ADJUSTABLE".
- ▶ Create the minimum (4 mA) and maximum (20 mA) for the measured variable.

8.1.7 Configuration External Control (Option: I/O Module)

To use this function, an I/O module must be present and the function must be enabled.

With this function it is possible to control the analyser remotely. The following operations can be carried out with the help of the external control:

- Sampling.
- Triggering a stand-by mode.

The commands are given by a 4-digit binary code, which is transmitted by four external signals. There are a total of three different transmission paths:

- Through four potential-free relays.
- Through four 4...20 mA inputs.
- Through one 4...20 mA input.
- Through the RS 485 interface.

Setting up external control

An external control can be set up on an IO module via the upper analogue outputs.

- ▶ Open the path "EXTRAS / GENERAL SETTINGS".
- ▶ Select "EXTERNAL CONTROL" here.
- ▶ Use the *left/right arrow keys* to select the desired external control.

By selecting the external control, the unit can be controlled remotely.

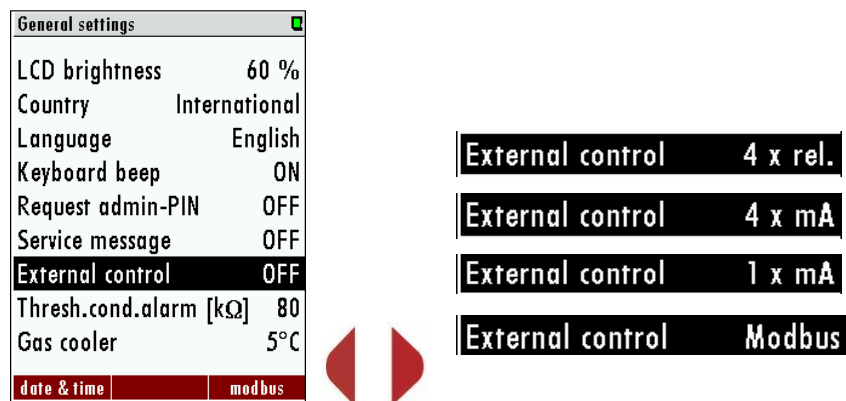

General settings	
LCD brightness	60 %
Country	International
Language	English
Keyboard beep	ON
Request admin-PIN	OFF
Service message	OFF
External control	OFF
Thresh.cond.alarm [kΩ]	80
Gas cooler	5°C

External control	4 x rel.
External control	4 x mA
External control	1 x mA
External control	Modbus

Activating the external control with the respective 4 possible options.

By activating the external control, a small arrow appears in the upper bar.

- ▶ You can set the zero point time, the suction / reaction time or the rinsing time before stand-by in the menu "General settings" with F2 (=ext Ctrl.).

After everything has been set, the external remote control must be wired.

Connecting the external control through 4 relays

This function can be used for external switching between the tapping points. For this purpose, four external relays (e.g. from a PLC) are connected to the module inputs.

The four relays together form a binary 4-bit code: RC4-RC3-RC2-RC1.

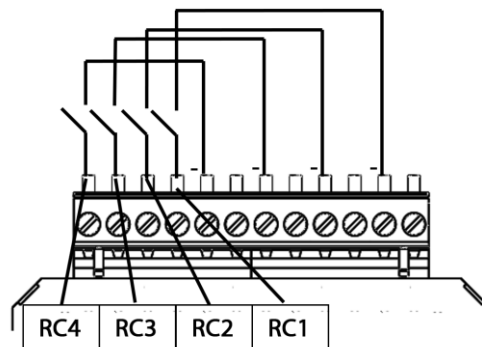

Status of external signal source				Status number	Description
RC4	RC3	RC2	RC1		
0	0	0	0	0	Automatic sampling point switching
0	0	0	1	1	Analyzer is sampling the point SP1 (*1, *2)
0	0	1	0	2	Analyzer is sampling the point SP2 (*1, *2)
0	0	1	1	3	Analyzer is sampling the point SP3 (*1, *2)
0	1	0	0	4	Analyzer is sampling the point SP4 (*1, *2)
0	1	0	1	5	Analyzer is sampling the point SP5 (*1, *2)
0	1	1	0	6	Analyzer is sampling the point SP6 (*1, *2)
0	1	1	1	7	Analyzer is sampling the point SP7 (*1, *2)
1	0	0	0	8	Analyzer is sampling the point SP8 (*1, *2)
1	0	0	1	9	Analyzer is sampling the point SP9 (*1, *2)
1	0	1	0	10	Analyzer is sampling the point SP10 (*1, *2)
1	0	1	1	11	Analyzer is "stand-by" (*3)
1	1	0	0	12	Purge phase for H2S-low-sensor **
1	1	0	1	13	Auto-Calibration
1	1	1	0	14	Remote reset of all system alarms
1	1	1	1	15	Analyzer is "stand-by" (*3)

**only SWG100-BIOGAS.

Here means: 0= Open / 1=Closed.

Connecting an external control through four 4-20 mA input signals

The 4-bit status number is formed by four 4...20 mA signals. I4-I3-I2-I1 are:
0-11 mA = 0 signal (low) / 11/12-20 mA = 1 signal (high).

General settings	
LCD brightness	60 %
Country	International
Language	English
Keyboard beep	ON
Request admin-PIN	OFF
Service message	OFF
External control	4 x mA
Thresh.cond.alarm [kΩ]	80
Gas cooler	5°C

date & time ext. ctrl. mod bus

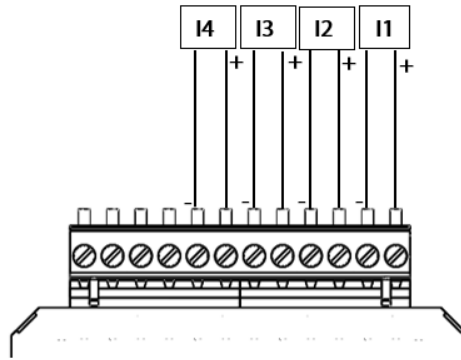

Status of external signal source				Status number	Description
I4	I3	I2	I1		
0	0	0	0	0	Automatic sampling point switching
0	0	0	1	1	Analyzer is sampling the point SP1 (*1, *2)
0	0	1	0	2	Analyzer is sampling the point SP2 (*1, *2)
0	0	1	1	3	Analyzer is sampling the point SP3 (*1, *2)
0	1	0	0	4	Analyzer is sampling the point SP4 (*1, *2)
0	1	0	1	5	Analyzer is sampling the point SP5 (*1, *2)
0	1	1	0	6	Analyzer is sampling the point SP6 (*1, *2)
0	1	1	1	7	Analyzer is sampling the point SP7 (*1, *2)
1	0	0	0	8	Analyzer is sampling the point SP8 (*1, *2)
1	0	0	1	9	Analyzer is sampling the point SP9 (*1, *2)
1	0	1	0	10	Analyzer is sampling the point SP10 (*1, *2)
1	0	1	1	11	Analyzer is "stand-by" (*3)
1	1	0	0	12	Purge phase for H2S-low-sensor **
1	1	0	1	13	Auto-Calibration
1	1	1	0	14	Remote reset of all system alarms
1	1	1	1	15	Analyzer is "stand-by" (*3)

Connecting an external control 4-20 mA input signal (via one input)

The user has the possibility to control the analyser externally by only one input signal (see sketch below). Different commands are given by the current level at measurement input I1. The zero signal corresponds to 4 mA. Each 1 mA level describes a state. Thus, the external control can assume up to 16 states. The first state corresponds to 5 mA (4 mA+1 mA) the second to 6 mA (4 mA+2mA) etc. until the signal reaches 20 mA.

General settings	
LCD brightness	60 %
Country	International
Language	English
Keyboard beep	ON
Request admin-PIN	OFF
Service message	OFF
External control	1 x mA
Thresh.cond.alarm [kΩ]	80
Gas cooler	5°C

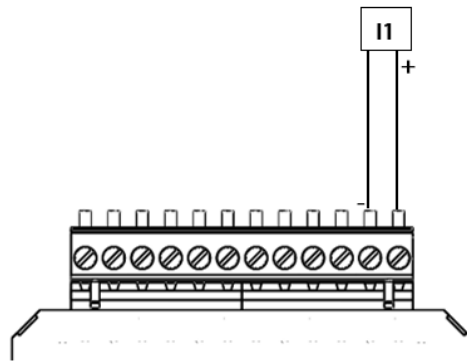

Status der externen Signalquelle	Status Nummer	Bechreibung
4	0	Automatic sampling point switching
5	1	Analyzer is sampling the point SP1 (*1, *2)
6	2	Analyzer is sampling the point SP2 (*1, *2)
7	3	Analyzer is sampling the point SP3 (*1, *2)
8	4	Analyzer is sampling the point SP4 (*1, *2)
9	5	Analyzer is sampling the point SP5 (*1, *2)
10	6	Analyzer is sampling the point SP6 (*1, *2)
11	7	Analyzer is sampling the point SP7 (*1, *2)
12	8	Analyzer is sampling the point SP8 (*1, *2)
13	9	Analyzer is sampling the point SP9 (*1, *2)
14	10	Analyzer is sampling the point SP10 (*1, *2)
15	11	Analyzer is "stand-by" (*3)
16	12	Purge phase for H2S-low-sensor **
17	13	Auto-Calibration
18	14	Remote reset of all system alarms
19	15	Analyzer is "stand-by" (*3)

General notes on external control

Case 1: Stand-by

The stand-by mode is activated when the status number exceeds the number of installed measuring points (example: 4 installed measuring points and active status number is 5). A stand-by mode has the following sequence:

- Purging via zero gas connection (depends on configured time).
- Stand-by mode until a status number is entered that corresponds to an installed measuring point.

Case 2: Active external control for a measuring point

- Zero point: First a zero point is taken. The running time of the zeroing can be set in the ext.Str menu.
- Gas aspiration: During the gas aspiration phase, the entire system is purged with sample gas to reach the T90 time of the analyser.
- Measurement: The measurement is started after the "gas aspiration" phase. The unit remains in measurement mode until the signal from the external control is changed. The table below shows the possible status numbers that can be assumed by the analyser.

(*1): Each time the measuring point is changed, the analyser takes a zero before measuring at the next measuring point.

(*2): Not only 11 to 15, but all status numbers greater than the number of installed measuring points will start the "stand-by" status.

(Example: if there are 4 measuring points, status numbers 5 to 15 will be set to "stand-by").

(*3): When the status number changes to a "stand-by" number, the sensors are purged, all solenoid valves are closed and the gas pump is switched off. If the status number changes to a smaller or the same number of installed measuring points, then a zeroing cycle begins and then measurement starts at the selected measuring point.

NOTE

The "stand-by" status can simply be used to start only one zero point measurement without "stand-by" and without changing the measuring point.

Example: - Status number=1 (for each time period, recommended max. 1 hour)

- Status number=15 (for a few seconds, recommended min. 10 seconds).

8.2 TCP to Modbus RTU Converter

PREREQUISITE:

- Micro USB cable.
- Ethernet cable
- Seneca Software Device Discovery or Software Easy-Setup (included on SD card).
- MRU4Win or Modbus Poll software.

8.2.1 Ethernet different states

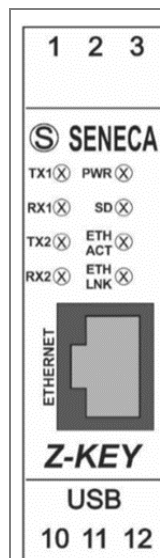

LED	Status	Description
TX1	---	No connection
RX1	---	No connection
TX2 (Red)	Flashing	Data reception at port # 2 RS485
RX2 (Red)	Flashing	Data reception at port # 2 RS485
PWR (Green)	On	Power on
SD (Red)	Flashing	Access to Mirco SD card
ETH ACT (Green)	Flashing	Übertragung an Ethernet Port
ETH ACT (Green)	On	No activity on Ethernet port
ETH LNK (Yellow)	On	Connected to Ethernet port
ETH LNK (Yellow)	Off	No Ethernet connection

8.2.2 Setting up Ethernet

The first step is to connect the TCP/RTU Modbus converter. 1.

▶ Switch on the unit.

▶ Connect the converter module to the network.

The power LED of the converter module will light up. In the next steps, configure the module with the programme "Seneca Discovery Device".

▶ Start the programme "Seneca Discovery Device".

▶ Press the "Scan..." button.

The converter is searched for in the network and indicated in the list.

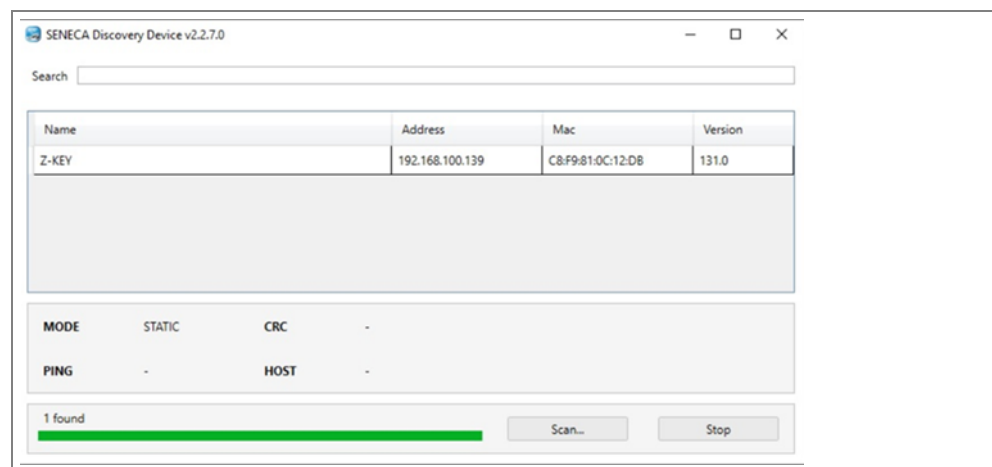

▶ The "Assign IP" button appears after the scan. Press the "Assign IP" button.

An input window appears.

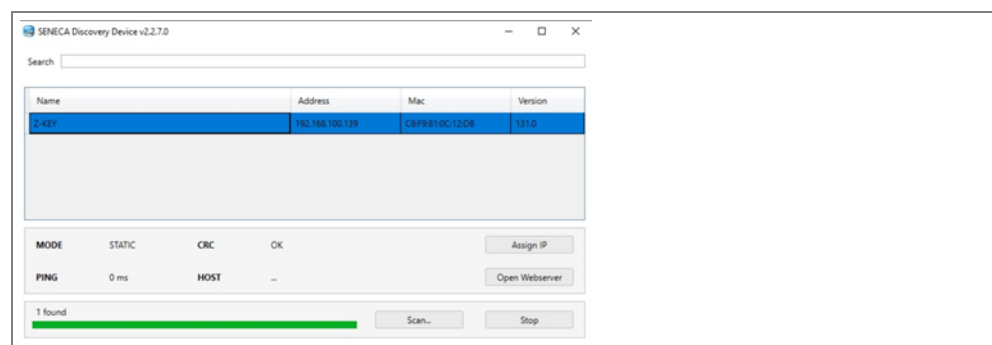

▶ Enter the IP address, submask and gateway in the input window. Alternatively, you can activate DHCP.

▶ Press the "Open Webserver" button.

The web server opens.

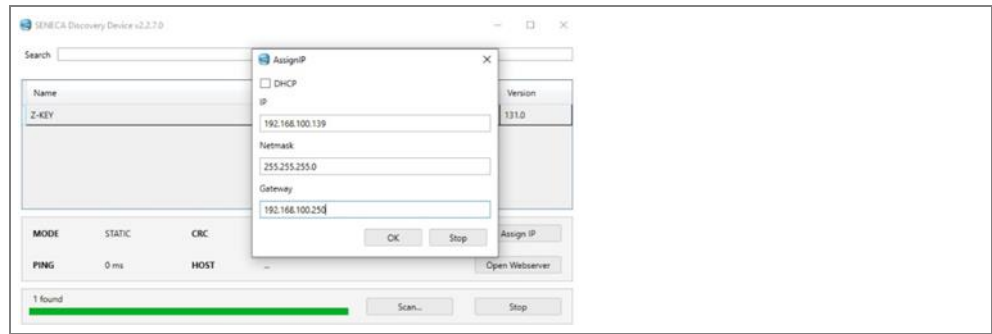

- ▶ Enter the user name "admin" and the password "admin".
An input field appears in which you can make the settings.
- ▶ Go to the menu "Setup".
- ▶ In this setting field, enter both the TCP data and the Modbus RTU data of your unit.

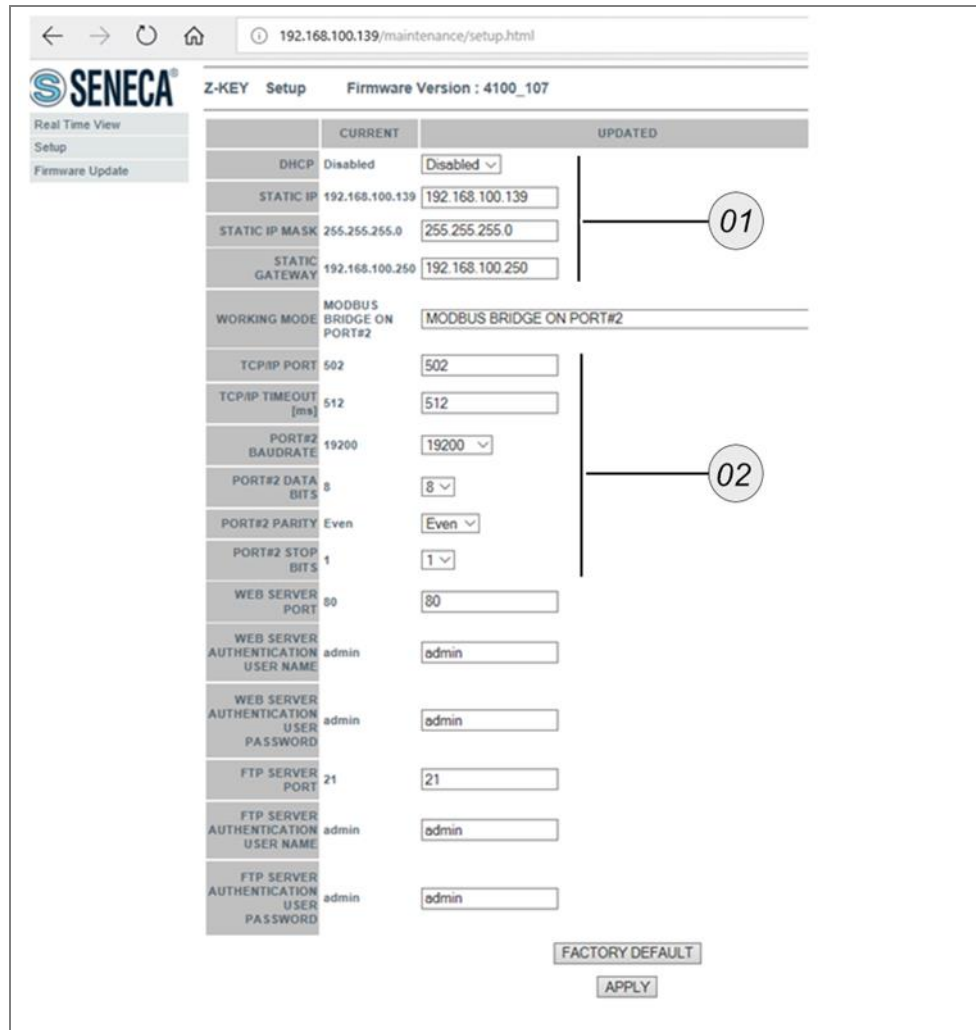

#	Description
1	Enter TCP data: IP address, submask, gateway
2	Enter RTU data of device: baud rate, stop bits, parity, data bits.

In the next step, adjust the Modbus RTU settings on the device.

- ▶ Open the menu EXTRAS / GENERAL SETTINGS F3 = MODBUS.
- ▶ In this menu, adjust the Modbus RTU settings so that the settings match the RTU settings on the web server.
- ✓ The converter is set. The counter counts up in the Modbus window.

8.3 Option: Profibus-converter

The Profibus converter allows a direct communication between Modbus (RTU) and a Profibus interface.

- The option is only available from firmware V1.01.70.
- Transfer multibyte values in Motorola[®] Order (Big Endian).
- CRC16 at the end of each frame is transmitted with Intel[®] Order (Little Endian). In case the master system needs Little Endian Order.
- 16bit values in frame swap bytes 01.
- 32bit values in data swap byte 03 and bytes 2.
- All addresses shown here are decimal and not hexadecimal.
- All readable addresses are 32bit values.
- The meter accepts for reading only even addresses and even register numbers.

The data types used are:

- U32: 32 bit unsigned integer values (0...4,292,967,259).
- FL: 32 bit floating point values (reads -1E38 if not included).
- Some values are only optional (e.g. gas cooler).

The data types used are:

- U32: 32 bit unsigned integer values (0...4,292,967,259).
- FL: 32 bit floating point values (reads -1E38 if not included).
- Some values are only optional (e.g. gas cooler).

8.3.1 Connect device with Profibus

Prerequisite

- 9-Pin SUB connector cable.

8.3.2 Connection to device

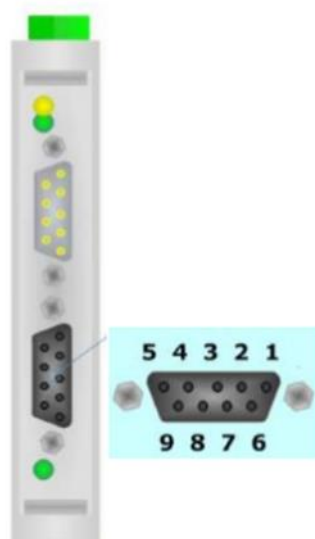

03 = Connection A, 04 = , 05 = GND (insolate Ground), 06 = Positiv Connection, 07 = , 08 = Connection B

8.3.3 Device settings

The settings are as followed:

Under the menu EXTRAS/GENERAL SETTINGS → MODBUS (F3) set the parameters.

The request parameters rise by a correct connection.



Modbus-Slave-Einstellungen	
Baudrate	19200
Slave-Adresse	238
Stoppbits	1
Parität	gerade
Datenbits	8
Anfragenanzahl	1425
zurück	

8.3.4 Special information about Modbus-Slave function

The device can work as a Modbus slave via RS232 or RS485 (possible with an external RS232/RS485 adapter).

- Supports RS485 interface with 2/4 wire function (half/full duplex).
- Supports Modbus binary protocol (RTU) only.
- Supports the Modbus command Read Holding Register (command no. 3).
- Supports the Modbus command Read Input Register (command no. 4).
- The slave Modbus address can be set by the user between 1 and 238.

The communication parameters can be defined by the user as follows:

- 9600 or 19200 baud (recommend 19200)
- Even , odd or none parity
- 1 or 2 Stopp-Bits.
- With a read command max. 63 32-Bitvalues can be read (126 Modbus registers).

8.3.5 Special information about Profibus – Slave function

- The Profibus slave function requires a Modbus Profibus converter "Seneca HD67561" installed and configured in the measuring device.
- The Profibus ID is normally set to 84 by MRU.

8.4 Option: RS-485 to USB converter

The RS485/USB converter enables the communication of the device via the Modbus location with a RS-485 compatible device. The receiving device can be e.g. a normal PC.

8.4.1 RS-485 Converter connection and configuration

STEPS:

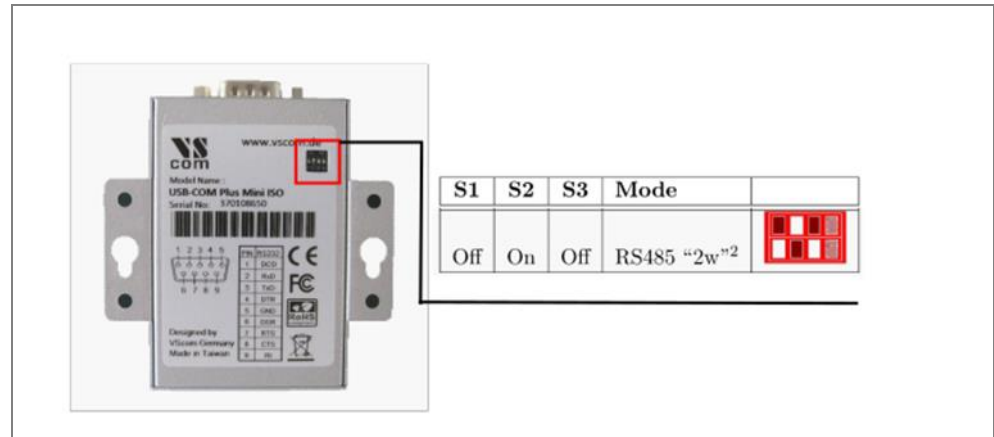

Fig. 1

- ▶ Set the DIP switch to RS-485 mode. The DIP switch is located on the back of the RS converter (Fig.1).

NOTE

Install the USB driver on the computer. The driver is already installed on most PCs. The driver can be downloaded from the homepage: <http://www.visionsystems.de/produkte/usb-com-plus-mini-usb-com-plus-mini-iso.html>.

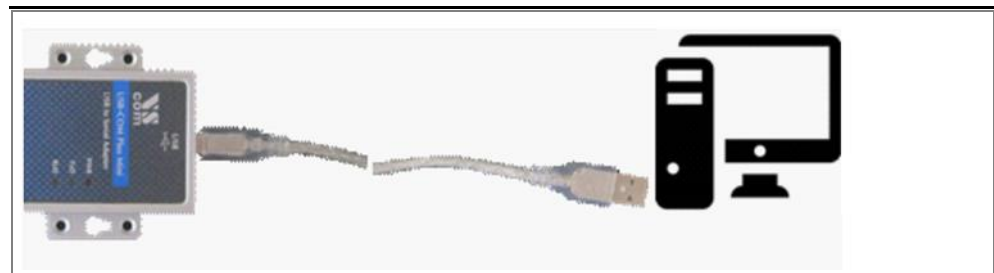

Fig.2

- ▶ Connect the RS-485 converter with an USB cable to the PC (Fig. 2).

The PC recognise the RS-485 converter. You can find the device in the device management of the PC.

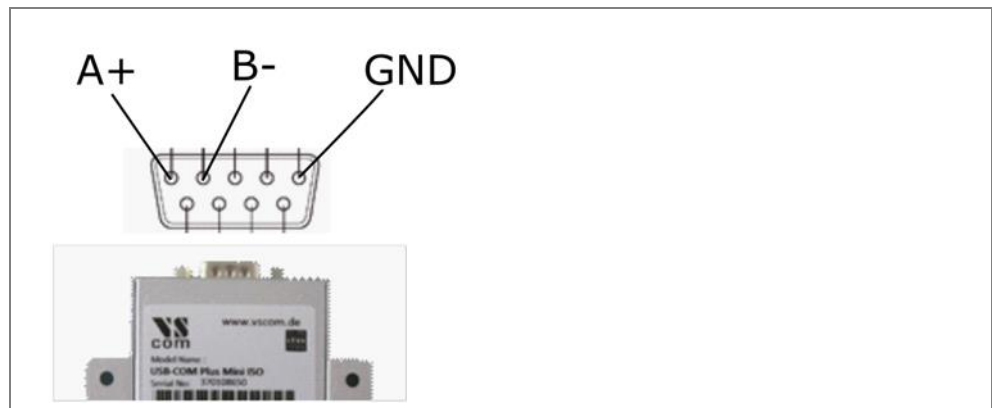

Fig. 3

- ▶ Connect the RS485- converter with the device. The connection will be built between the converter and the PC (Fig. 3).
- ▶ Open the menu Extras on the device: EXTRAS/GENERAL SETTINGS
- ▶ Open the submenu Modbus (F3).
- ▶ Make the settings into the menu. These includes: Baudrate, parity, Stop- Bits etc.
- ✓ The device is connected to the RS- 485 converter.

NOTE

Data can be viewed and logged by suitable software on the PC. If you do not have software, you can buy and use the MRU4Win software.

8.5 Option: MRU4Win

MRU4Win is a log software. Through the software you can log and save data from the device. The software can detect devices with TCP protocol and RS-485 Modbus protocol (RTU).

8.5.1 MRU4Win start and settings

PREREQUISITE:

- The device must be connected to a suitable converter and be able to communicate.

STEPS:

- ▶ Open the software on your PC. 2.

- ▶ Open "Create Modbus Device".

An input window appears in which you can select the respective protocol.

- ▶ For RS-485: select Modbus RTU. Set the same settings here as in the device. Baud rate, parity etc. must match.

- ▶ For TCP: select TCP. Set here the same settings as in the device. IP address, submask etc. must match.

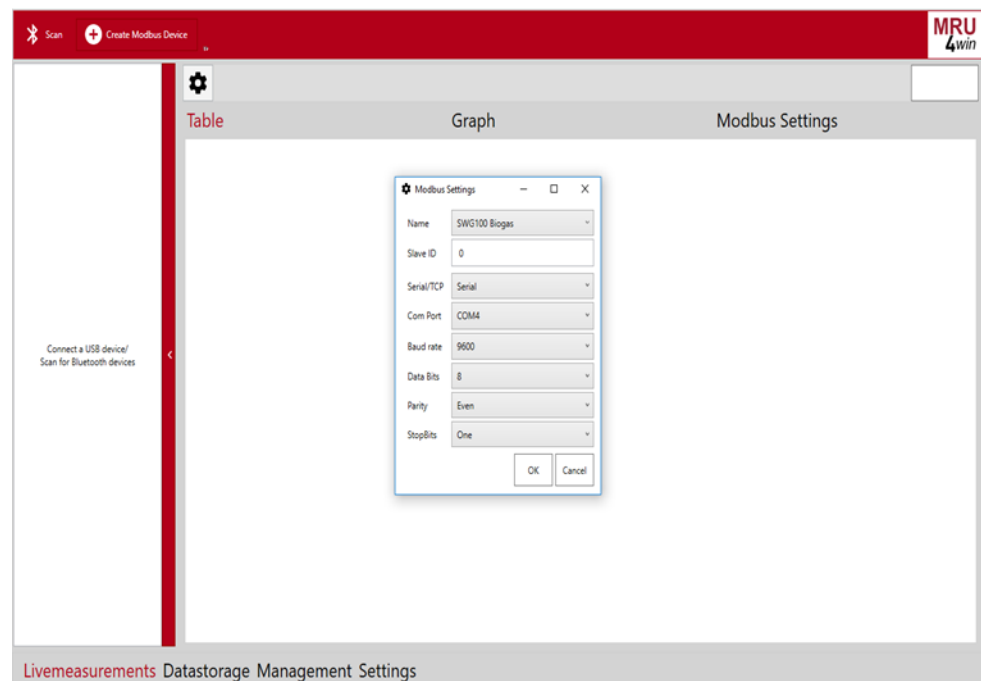

The connected device is displayed on the left side.

- ▶ Press the Connect icon.

- ▶ The live values from the device are visible on the PC. The values can be displayed as a curve or as a number. Logging and saving is possible.

8.6 Flame arrester

A flame arrester is a close-meshed metallic structure that must have a certain length depending on the volume flow. If a flame hits the structure, it is cooled down and extinguished.

Here you will learn how to fit a flame arrester.

PREREQUISITE

- Open-end spanner SW 18
- Open-end spanner SW 21

STEPS

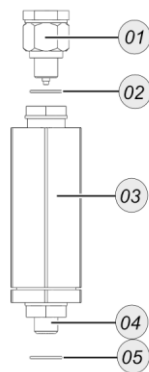

#	Description
1	DN6/4 filter-nozzle-unit
2	G1/8 copper seal
3	Flame arrester
4	G1/8 outer thread
5	G1/8 copper seal

- Put the large copper seal over the thread of the flame arrester (05) and (04).
- Tighten the flame arrester with an open-end spanner SW 21.
The flame arrester is mounted.
- Put the small copper seal over the thread of the flow limiter.
- Tighten the flow limiter with an open-end spanner SW 18.
- The assembly is mounted.

NOTE

You can connect the gas inlet with a DN4/6 mm PTFE hose.

8.7 Option: LEL-Sensor

8.7.1 Safety device: LEL sensor



⚠ WARNING

Maintenance of safety-related equipment

The unit is equipped with LEL sensor that measures the leakage of CH₄ inside the cabinet. The sensor is designed to detect explosive atmospheres inside the unit and will trigger an alarm relay in case of danger.

- Connect the system alarm relay to a PLC if possible.
- Check the display information and warnings at regular intervals.



The unit has an internal LEL sensor (pellistor) that monitors the CH₄ concentration inside the unit. The pellistor is intended to warn the operator when the CH₄ concentration exceeds a critical value.

The following table shows the different states for the different possible cases.

Status	Display Message	System Alarm Relais contact	Modbus Device Status	Modbus System Alarm	Device
Measured pellistor value > Alarm threshold	Yes	open	set	Bit Pellistor alarm set	Gas inlet closed, pump off
Any period without exceeding a minimum gas concentration, user setting "Pellistor Check Alarm = OFF"	No	closed	not set	-	Measuring operation
5 months without exceeding a minimum gas concentration, user setting "Pellistor Check Alarm = ON"	Yes	closed	not set	-	Measuring operation
7 months without exceeding a minimum gas concentration, user setting "Pellistor Check Alarm = ON"	Yes	open	set	Bit Pellistor Checkreq. set	Measuring operation

8.7.2 Maintaining and calibrating the LEL sensor

Here you will learn how to maintain an LEL sensor.

- The LEL sensor should be serviced regularly every month, at least every 6 month.
- After 5 months, the unit will give a warning message on the display that you need to service the sensor.

PREREQUISITE:

- LEL-calibration cap (can be ordered → see current price list)
- CH4-gas can with CH4=1-2 vol.% / rest synthetic air.

LEL-Sensor cap #12397	CH4-gas can (example MINICAN from Linde) must be organised by user
	

STEPS:

ATTENTION

Sensor damage

CH4 concentrations above 100 % LEL can cause long-term damage to the sensor.

- CH4 concentrations of 5 % by volume corresponds to 100 % LEL.

▶ Open the menu: EXTRAS / ABGLEICH PELLISTOR.

<p>Adjustment menu OFF 0.0</p> <p>EC adjustment by factor</p> <p>EC adjustment by nom. value</p> <p>Adjustment Multi Gas Bench</p> <p>Adjustment H2-TCD</p> <p>Adjustment p-barometric</p> <p>Adjustment pellistor</p> <p>Adjustment smp. flow meas.</p> <p>Adjustment case flow</p> <p>Hardware state & tests</p>	<p>Adjustment pellistor</p> <p>CH4 internal -0.010 %</p> <p>CH4 internal (LEL) 0.00 %</p> <p>Pellistor [mV] -0.24</p> <p>Zero offset [mV] -3.50</p> <p>Factor 1.000</p> <p>Alarm level [%LEL] 5</p> <p>Next check alarm 06/01/2023</p> <p>default zero point</p>
---	---

i All values are given in LEL. The table below shows you which LEL value corresponds to which vol.%, as on most gas cans the information is in ppm.

LEL [%]	CH4 concentration [%]
100 % LEL	5 vol. %
50 % LEL	2,5 vol. %
25 % LEL	1,25 vol. %

- ▶ Press F3 = Zero point.
The zero point is taken. In the menu you see the value 0.000%.
- ▶ Go to the menu item Alarm threshold [%LEL].
- ▶ Set your desired alarm threshold [%LEL] with **the left / right arrow key**.
- ▶ Connect the calibration adapter to the pressure reducer of the CH4 gas can.

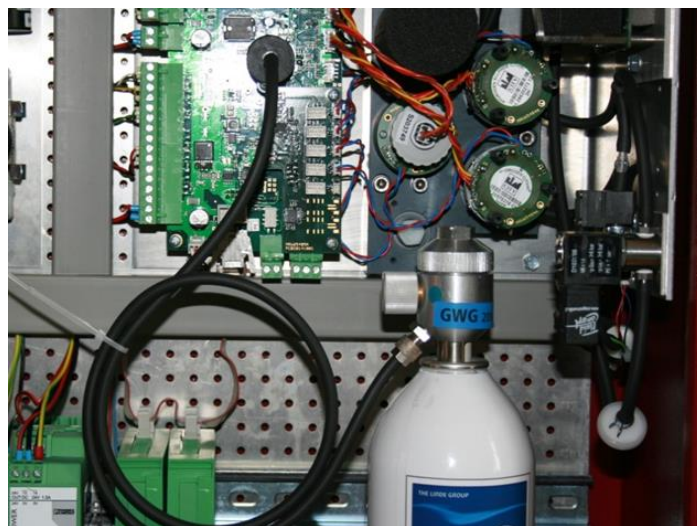

Fig.1

- ▶ Put the calibration adapter on the LEL sensor (see fig.1 here in a biogas unit).
- ▶ Open the CH4 gas can.
The LEL actual concentration changes.
- ▶ Wait until the gas concentration is stable.
- ▶ Change the factor with **the left / right arrow key** until the displayed LEL actual value corresponds to the setpoint value of the cylinder.
- ▶ Exit the menu.
- ▶ Confirm the saving.
- ✓ The LEL sensor is calibrated.

8.7.3 Replacing the LEL sensor

Here you can find out how to replace an LEL sensor.

STEPS:

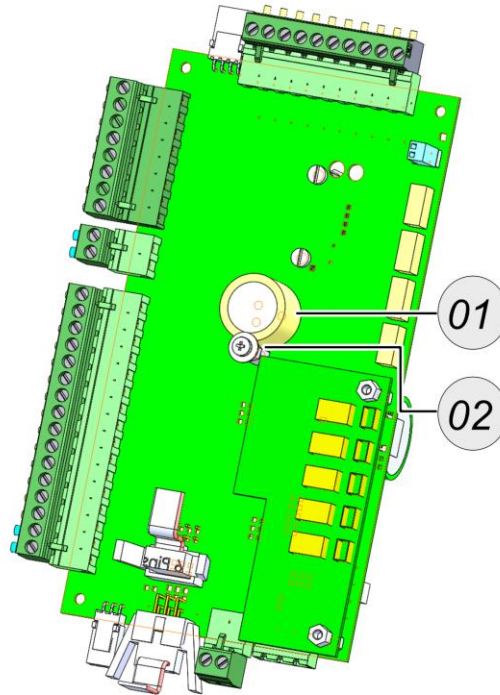

#	Description
1	LEL-Sensor
2	Retaining screw

- ▶ Unscrew the retaining screw from the LEL sensor.
- ▶ Pull the LEL sensor out of the board.
- ▶ Insert the new LEL sensor into the circuit board.
- ▶ Screw the retaining screw back onto the LEL sensor.
- ▶ Adjust the sensor.
 - ↳ See chapter 8.7.2.
- ✓ The LEL sensor is adjusted.

8.8 Option: 11247A Condensate Trap with Filter

The external condensate trap is a pre-filter unit that is used for humid and polluted flue gas.

8.8.1 Fitting the condensate trap

Here you will learn how to mount the condensate trap.

PREREQUISITE:

- Stopcock for DN4/6 mm PTFE hose.

STEPS / ASSEMBLY

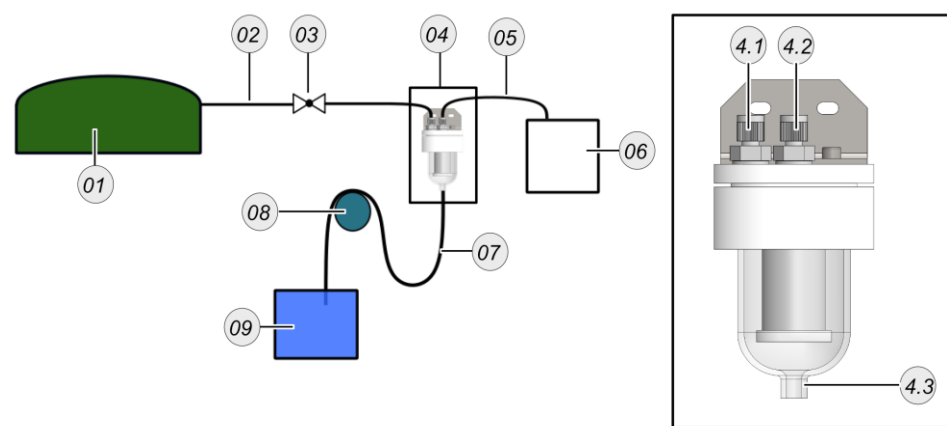

#	Description
1	Sample measurement point (for example fermenter)
2	Sample gas inlet (DN 4/6 mm PTFE-line)
3	Absperrhahn für DN4/6 mm PTFE-line
4	Condensate trap
4.1	GAS-IN = Condensate trap inlet DN 4/6 mm
4.2	GAS-OUT = Condensate trap outlet DN 4/6 mm
4.3	Condensate outlet DN 4/6 mm
5	Sample gas inlet-hose (DN 4/6 mm PTFE-line)
6	Device with Sample gas inlet for DN 4/6 mm PTFE-line
7	Condensate hose DN4/6 mm
8	Condensate hose holder
9	Condensate canister

Fig. 1

- ▶ Plan the correct mounting location in advance.
 - ◻ Ideally, the PTFE lines are mounted horizontally and at the same level as the gas inlet.

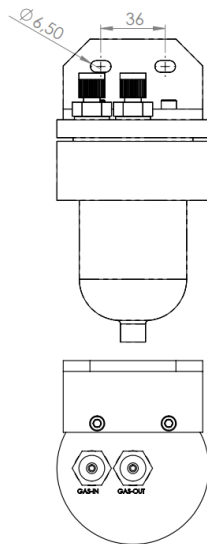

Fig. 2

- ▶ Screw down the condensate trap with suitable screws / fastening measures.
- ▶ Screw the condensate hose holder horizontally to the condensate trap outlet.
- ▶ Place a 1 m loop from the condensate trap outlet over the condensate hose holder.
 - ◻ 1 m = 100 hPa.
- ▶ Connect the condensate trap outlet to the sample gas inlet of the unit.
 - ◻ Please note: Line length l max. < 100 m.
- ▶ Connect the inlet of the condensate trap to the measuring probe on the fermenter.
- ▶ Install a stopcock between the condensate trap-fermenter line at an easily accessible point.
- ✓ The condensate trap is mounted.

9 Service and maintenance

⚠ WARNING

Risk of electric shock from the power system voltage

This may result in severe injuries or death.

- Disconnect the device from the power supply before doing maintenance work.
- Check that the system is deenergized.

⚠ CAUTION

Risk due to incorrect maintenance

Malfunctions may occur.

- Scheduled maintenance must be performed by qualified technicians.

⚠ CAUTION

Risk of burn during maintenance work

Burn may result.

- Disconnect the device from the power supply before doing maintenance work.
- Let hot components cool down sufficiently.

The reliable function and measurement quality of the unit can only be guaranteed with regular inspection and maintenance.

In addition to regular routine checks by the operator, the manufacturer recommends regular ½-yearly maintenance (2x per year) of the analyser by a qualified specialist company to maintain reliable function and high measurement quality.

9.1 Preparation and instruction for maintenance

For maintenance work, the main fuse in the unit must be switched off. Even when the main fuse is switched off, dangerous electrical voltages are present on the primary fuse side.

If necessary, disconnect the unit from the electrical supply and secure it against being switched on again.

Dangerous gases may escape during maintenance work on the gas system. The gas supply to the unit must be switched off.

For electrical work as well as for work on the gas system, all nationally applicable directives must be observed at the installation site.

9.2 Regular maintenance work by the operator

All inspection and maintenance work is highly dependent on the individual conditions of use and operation on site. The specified intervals are therefore to be understood as guidelines.

Check	Recommended Interval	Action
Humidity in the device	Weekly	Remove humidity. Remove the cause of the humidity penetration.
Dirt and deposits in the application	Weekly	Remove dirt, prevent further penetration of dirt.
Dirt or humidity on fan filter	Weekly	Replace the fan filter mat.
Visually check gas lines for leaks and seating	Weekly	Replace gas lines if necessary
Inspect condition of gas filters and critical parts (see table)	Monthly	Exchange if necessary

The following lists the parts of the analyser that are critical to the reliable operation of the unit. These parts must be replaced at intervals independent of the regular inspection.

9.3 Maintenance parts: Position overview

9.3.1 The spare parts set #66114

The spare parts set #66114 contains all important spare parts.
You can see them in the table below:

Service-set: 66114

#	Element	Quantity	Article number
1	Maintenance set for nozzle-filter unit	1	11525
1.1	Sinter filter	2	65988
1.2	Sealing ring copper 1/4	2	61947
1.3	O-Ring	2	64798
1.4	Sealing ring copper 1/8	2	64509
2	Filter mats for fan	5	60320
3	Filter-inline PTFE 2...5µm	1	65533
4	Condensate pump head	1	60421
5	Filter-inline 0,3µm PTFE	1	66088
6	Fine filter assembly	1	65884



9.3.2 Spare part position outside

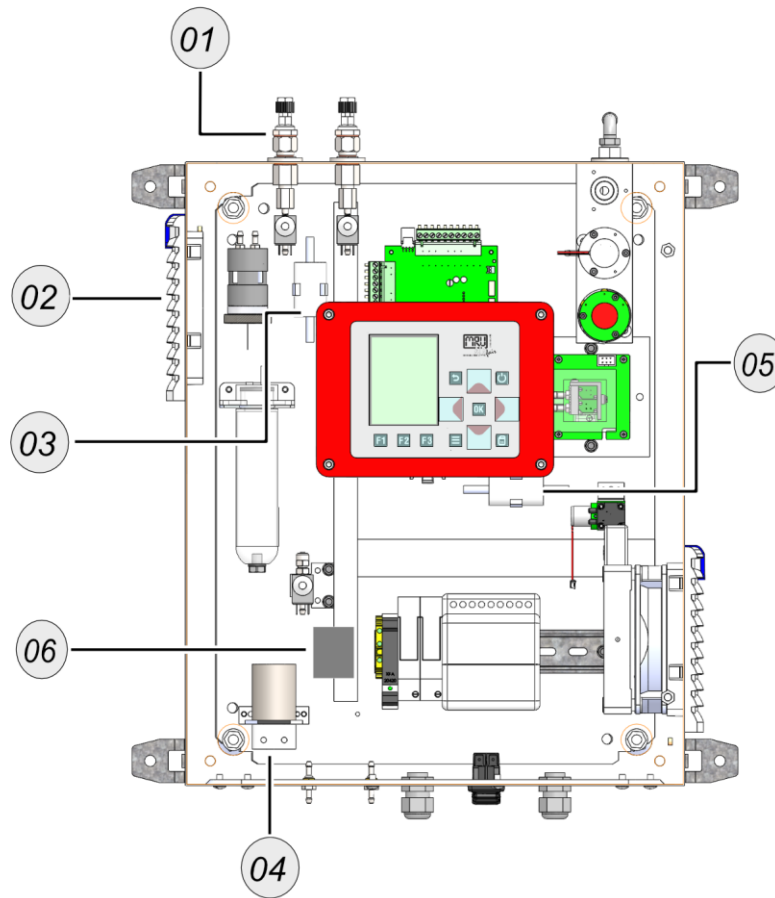

#	Element	Article number
1	Maintenance set for nozzle-filter unit	11525
2	Filter mats for fan	60320
3	Filter-inline PTFE 2...5µm	65533
4	Condensate pump head	60421
5	Filter-inline 0,3µm PTFE	66088
6	Fine filter assembly	65884

9.3.3 Replace filter-mat



PREREQUISITE

- New filtermat

STEPS



- ▶ Push the blue tab **01** of the filter housing.
The filter housing opens.
- ▶ Replace the filter-mat **02**.
- You have replaced the filter-mat.

9.3.4 Replacing the inline filter activated carbon



Inline filter activated carbon

Here you will learn how to replace an **inline filter**.

PREREQUISITES

- The device must be de-energised before replacement.

STEPS

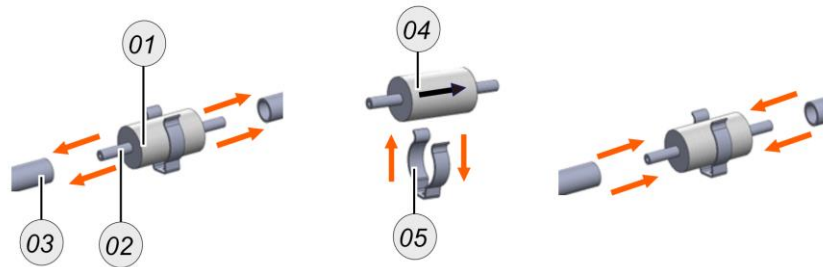

#	Description
1	Filter element
2	Inline filter connector
3	Hose
4	Installation direction
5	Clamp

- Pull the hoses **03** from the **inline filter connections 02**.
- Remove the used **Inline filter** from the clamp **05** if necessary.
The old **Inline filter 01** is removed.
- Attach a new **inline filter** to the clamp **05** if necessary.
- Reconnect the **Inline filter** connections to the hoses.
- You have replaced the **inline filter**.

9.3.5 Replacing the inline Sox / NOx filter



Inline-Filter SOx/NOx

Here you will learn how to replace an **inline filter**.

STEPS

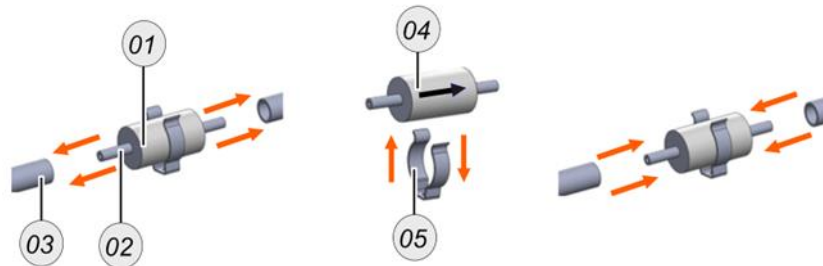

#	Description
1	Filter element
2	Inline filter connection
3	Hose
4	Installation direction
5	Clamp

- ▶ Pull the hoses **03** from the **inline filter connections 02**.
- ▶ Remove the used **Inline filter** from the clamp **05** if necessary.
The old Inline filter is removed.
- ▶ Attach a new **inline filter** to the clamp **05** if necessary.
- ▶ Reconnect the **Inline filter connections** to the hoses.
- ✓ You have replaced the **inline filter**.

9.3.6 Change filter-unit on nozzle

Here you will learn how to change the sinter-filter on the nozzle-filter unit.

PREREQUISITES:

- Spanner
- Sinter-filter
- O-Ring
- G1/8 copper seal
- G1/4 copper seal

STEPS:

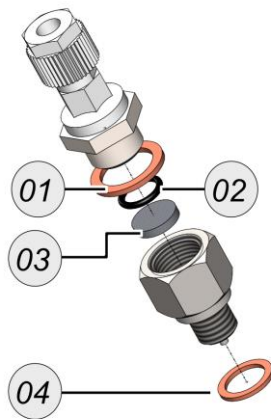

#	Article-name	Article-number
1	G1/4 copper seal	61947
2	O-ring	64798
3	Sinter-filter	65988
4	G1/8 copper seal	64509

- Remove the nozzle with a spanner.
- Remove the hose connector DN6/4 from the nozzle-filter unit.
- Replace the G1/4 copper seal (01), the O-ring (02), the sinter filter (03) and the G1/8 copper seal (04).
- The filter-unit on the nozzle is change.

9.4 Gas adjustment

The adjustment of the individual measuring sensors is described here.

The procedure is always the same, regardless of the measuring sensor:

- Connect the adjustment gas cylinder.
- Open the adjustment menu.
- Adjust the sensor in the right menu.

9.4.1 Connect adjustment gas cylinder

⚠ WARNING

Connecting calibration gas without pressure

The calibration gas must be connected to the zero gas / calibration connection without pressure via a bypass system.

⚠ WARNING

Adjustment installation not for permanent use

The adjustment device is intended for a permanent adjustment installation, as zero gas and adjustment gas share the same connection piece.

ATTENTION

Settings

- Pressure reducer Max.500 hPa
- Flow meter Approx. 60 l/h

Zero gas inlet and span gas inlet share one gas inlet. In most cases, the meter requires the zero gas inlet for its zeroing. In some cases it may be necessary to calibrate the meter with a calibration gas cylinder. Here it is important to know that the analyser needs a bypass system to calibrate the metrology with gas.

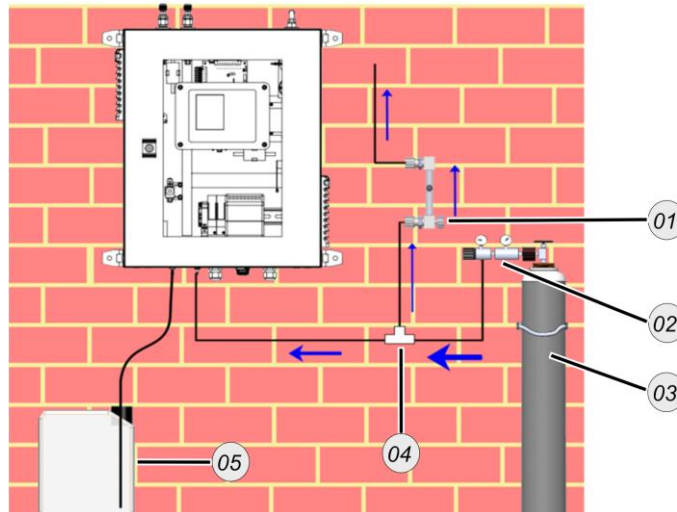

#	Description	#	Description
1	Flow meter	2	Pressure reducer = Set pressure reducer to 500 hPa
3	Adjustment gas cylinder	4	T-piece for gas division
5	Condensate container		

9.4.2 Adjust Multi Gas Bench

You can adjust the NDIR gas bench.

PREREQUISITE:

- Adjustment device must be mounted.



- Adjustment gas cylinder with following concentrations is needed:

CO2	39,95 Vol.%
CH4	60,00 Vol.%
H2S	500 ppm

ATTENTION

The adjustment gas cylinder must remain closed until you are instructed to open the adjustment gas cylinder.

STEPS:

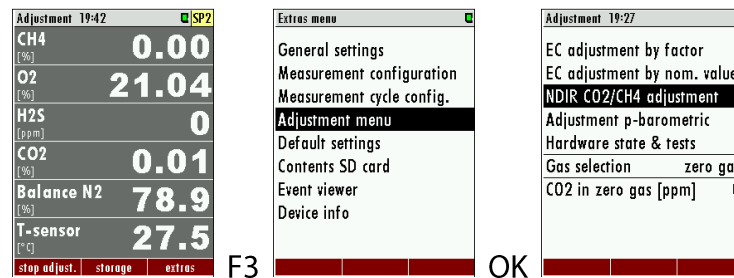

Fig. 1

- Open the menu: EXTRAS / ADJUSTMENT MENU.
- Open the adjustment menu IR CO2 / CH4 ADJUST (Fig.1).

The adjustment menu opens. The adjustment menu has the following structure.

NDIR CO2/CH4 adjustment	
CH4 [%]	-0.162
CH4 factor	0.984
CH4/CO2 cross sens.	0.186
CO2 [%]	0.059
CO2 factor	1.035
CO2/CH4 cross sens.	0.090
O2 [%]	21.07

#	Description
1	Gas name with actual value
2	Factor: Start value always 1,000
3	Cross sensity
4	Average (F1-Key)
5	Zero point (F2-Key)

- Open the adjustment gas cylinder.

The actual value in the adjustment window changes.

4 5

- ▶ Wait until the actual value no longer change.

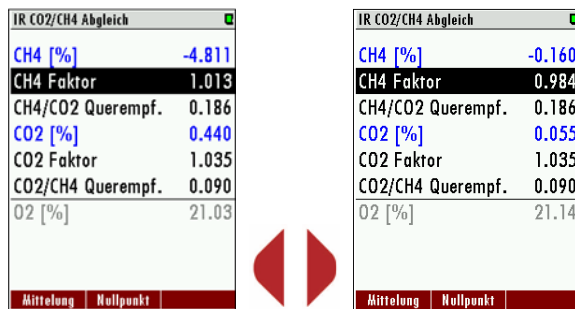

IR CO2/CH4 Abgleich	
CH4 [%]	-4.811
CH4 Faktor	1.013
CH4/CO2 Querempf.	0.186
CO2 [%]	0.440
CO2 Faktor	1.035
CO2/CH4 Querempf.	0.090
O2 [%]	21.03
Mittelung	Nulldpunkt

IR CO2/CH4 Abgleich	
CH4 [%]	-0.160
CH4 Faktor	0.984
CH4/CO2 Querempf.	0.186
CO2 [%]	0.055
CO2 Faktor	1.035
CO2/CH4 Querempf.	0.090
O2 [%]	21.14
Mittelung	Nulldpunkt

Fig. 2

- ▶ Select the gas to be adjusted (Fig.2).
- ▶ Change the factor with the left / right arrow key until the actual value corresponds to the adjustment gas cylinder.
 - Close the adjustment window.
 - You will be asked if you want to save the adjustment.
- ▶ Confirm that you want to save the adjustment.
 - The adjustment is saved.
- ✓ The adjustment is finished.

9.4.3 Adjust the electrochemical O2-sensor

Here you will learn how to replace and calibrate an electrochemical oxygen sensor.



O2-sensor

PREREQUISITE:

- O2 sensor (spare part)
- 100 vol. % N2 adjustment gas cylinder.
- Adjustment set-up must be set up

STEPS: INSTALL SENSOR

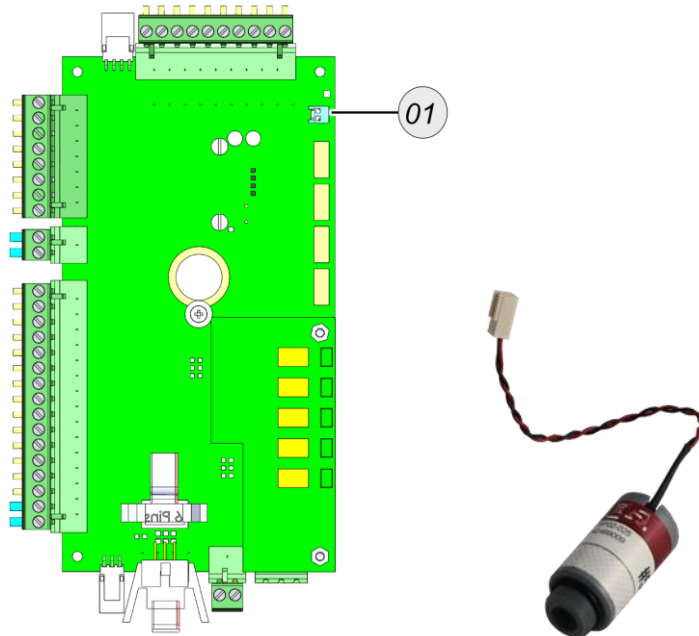

Fig. 1

- Unplug the O2 sensor to be replaced from the circuit board (Fig.1 (1)).

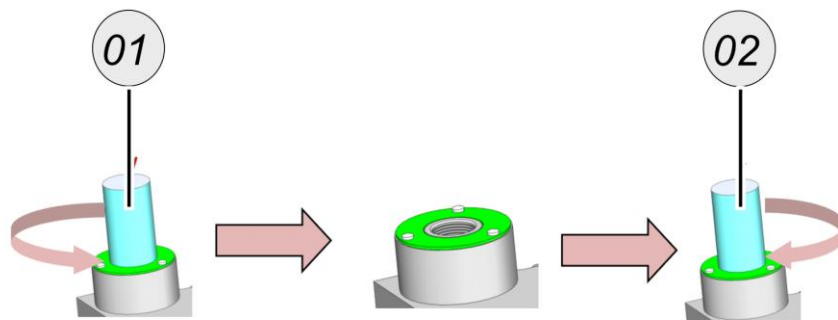

Fig. 2

- ▶ Rotate the O2 sensor to be submerged out of the sensor chamber (Fig.2 (1)).
- ▶ Turn the new O2 sensor into the sensor chamber (Fig.2 (2)).
- ▶ Insert the new O2 sensor into the circuit board.
- ✓ The O2 sensor is installed.

STEPS: ADJUSTMENT

- ▶ Open the adjustment menu: EXTRAS / ADJUSTMENT MENU .

A zero point measurement starts.

The O2-sensor is adjusted at 21 vol. % oxygen.

EC adjustment by factor			
O2	20.88 %		
H2S	-0.3 ppm	1.000	
O2=air			

Fig. 1

- ▶ Open the EC ADJUSTMENT BY NOM. VALUE menu item (Fig.1).

The ECS adjustment menu appears.

- ▶ Connect the 100 vol.% N2 gas cylinder to the adjustment setup.
- ▶ Open the N2 gas cylinder.

EC adjustment by factor			
O2	0.27 %	0.099	
H2S	-0.4 ppm	1.000	
set O2=0			

Fig. 2

The O2 value drops (Fig.2).

- ▶ Wait until the O2 value no longer changes.

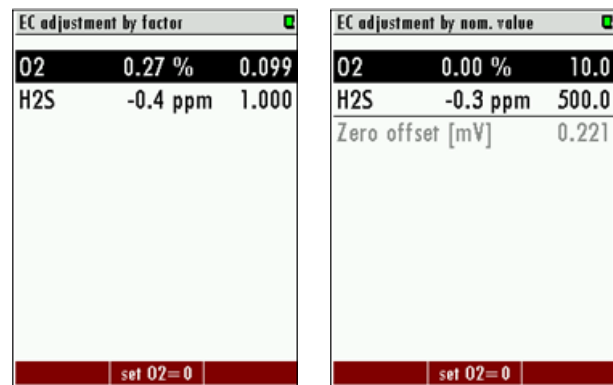

EC adjustment by factor		
O2	0.27 %	0.099
H2S	-0.4 ppm	1.000

EC adjustment by nom. value		
O2	0.00 %	10.0
H2S	-0.3 ppm	500.0
Zero offset [mV]	0.221	

Fig. 3

▶ Press F2. (Fig.3).

The O2 sensor is calibrated at the value O2=0 vol.%.

▶ Exit the menu.

▶ Confirm save.

✓ The O2 sensor is adjusted.

9.4.4 Adjustment electrochemical sensors



⚠ WARNING

Connect the adjustment gas-cylinder correctly

Adjustment gas-cylinder are under high pressure and may contain toxic gases. Can lead to death.

- Only trained personnel may connect adjustment gas-cylinder:

Here you will learn how to replace and adjust an electrochemical sensor. There are generally the following sensor designs:

#	Model	Removal instruction
1	A	👉 See section:
2	B	👉 See section:
3	C	👉 See section:



PREREQUISITE:

- Respective sensor
- Adjustment gas-cylinder with 70 % of the upper measuring range
- Adjustment setup must be set up

STEPS: INSTALLING SENSORS MODEL A

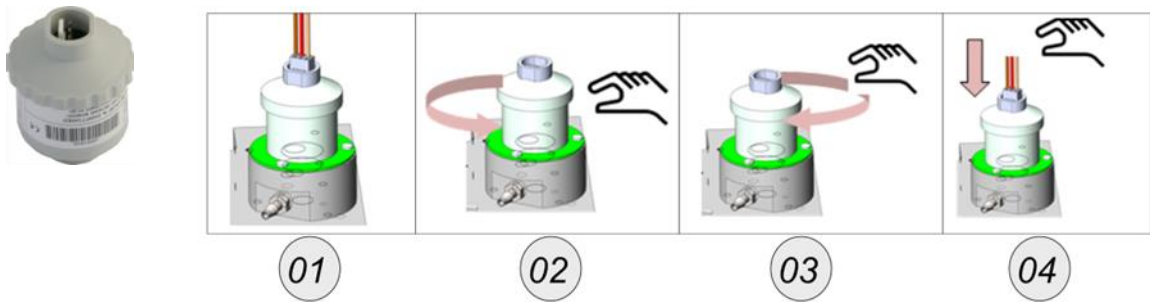

- Remove the plug from the sensor (1).
- Turn the sensor to be immersed out of the sensor chamber (2).
- Turn the new sensor into the sensor chamber (3).
- Put the plug back on the sensor (4).

✓ You have replaced the sensor.

STEPS: INSTALLING THE SENSORS MODEL B

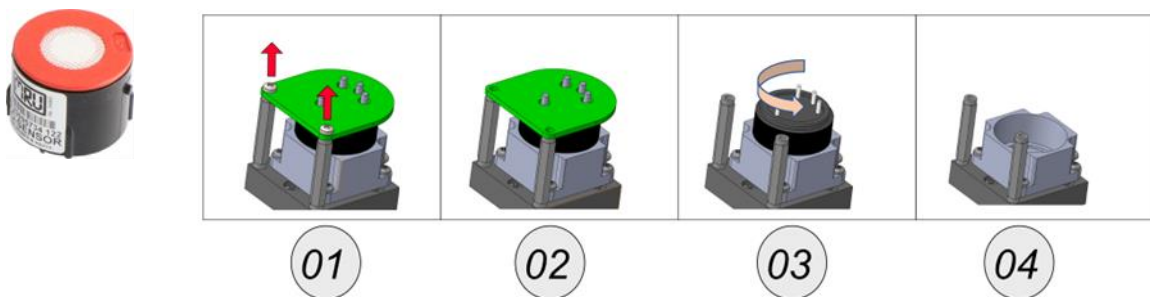

- Loosen the screws from the sensor board (1).
- Remove the sensor board from the sensor (2).
- Turn the sensor out of the sensor chamber (3).

The sensor chamber can be fitted with a new sensor.

- Install the new sensor.

✓ You have replaced the sensor.

STEPS: INSTALLING THE SENSORS MODEL C

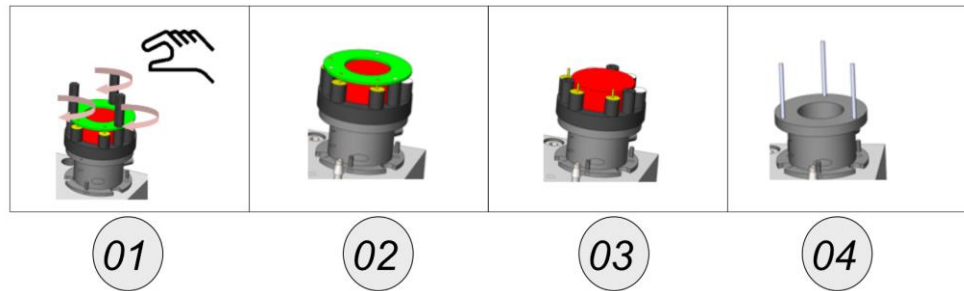

- Rotate the plastic holders from the circuit board (1).
- Remove the sensor board from the sensor (2).
- Remove the sensor from the sensor chamber (3).

The sensor chamber can be fitted with a new sensor.

- Install the new sensor.
- ✓ You have replaced the sensor.

STEPS: ADJUSTMENT



Abgleichflasche jetzt öffnen

- Open the settings menu: EXTRAS / SETTINGS MENU.
- Open the ECS ADJUSTMENT menu item.

The ECS setting menu appears.

▲ WARNING - High pressure. Connect the gas gas-cylinder correctly as described in the instructions.

- Connect the respective adjustment gas-cylinder to the adjustment fitting.

Now open the adjustment gas-cylinder

- Open the adjustment gas-cylinder.

The actual value changes in the adjustment window.

- Wait until the gas value no longer changes.
- Change the factor with the arrow key left/right until the setpoint of the gas gas-cylinder is reached.

The sensor is adjusted to the setpoint.

- Exit the menu.
- Confirm saving.
- ✓ The sensor is adjusted.

10 Technical data

10.1 General technical data

Deutsch	Daten / Data	English
Betriebsstemperatur(ohne Frostschutzheizung)	+5°C ... +45 °C / 41 °F ... 113 °F	Operating temperature (w/o heating)
Betriebstemperatur (mit optionaler Frostschutzheizung)	-10 °C ... +45°C / 14 °F ... 113 °F	Operating temperature (with internal heating, option)
Rel. Luftfeuchtigkeit bei Betrieb, nicht-kondensierend	< 95%	Rel. Humidity, non-condensing
Lagertemperatur	-20°C ... +50°C / -4°F ... 122°F	Storage Temperature
Schutzart	IP54	Protection Class
Aufstellbedingungen	geschützt vor direkter Sonneneinstrahlung und Regen / do not expose to direct sun light or rain	Installation Requirements
Akku intern, Pufferzeit für Sensor Bias	NiMH, 3 Monate / 3 months	Internal Battery Pack, buffer time for sensor bias
Stromversorgung	100 - 240 V, 200 W	Power supply
Gewicht, typisch mit Sensoren, Gaskühler	25 kg / 55 lbs	Weight, typically incl 2 sensors
Maße	500x400x210 mm (HxBxT) 19.69x 15.75 x8.27 in	Size
Gehäusematerial	lackierter Stahl/lacquered steel	Housing material
max. Unterdruckbereich der Gaspumpe	300 hPa	Max suction range gas pump
typischer Gasdurchfluss	50 l/h	gas flow typ.
Gerät ist für Intervallbetrieb, nicht für Dauerbetrieb, ausgerüstet		The unit is intended to be operated in intervals, non continuously

10.2 Technical data: NDIR-bench

Nicht-dispersive Infrarotmessung (NDIR)	CO₂	Non-dispersive Infrared Measurement (NDIR)
Nominaler Messbereich	0 .. 100 Vol%	Nom. Measuring Range
Auflösung	0,01 Vol%	Resolution
Genauigkeit abs. /vom Messwert	± 0,3 Vol% / 3%	Accuracy abs./reading
Ansprechzeit T90	< 35 s	Response Time T90
Nicht-dispersive Infrarotmessung (NDIR)	CH₄	Non-dispersive Infrared Measurement (NDIR)
Nominaler Messbereich	0 .. 100 Vol%	Nom. Measuring Range
Auflösung	0,01 Vol%	Resolution
Genauigkeit abs. /vom Messwert	± 0,3 Vol% / 2%	Accuracy abs./reading
Wiederholbarkeit abs. /v. Messwert (d.h. Genauigkeit nach Kalibrierung an diesem Punkt)	± 0,01 Vol% / 0,1%	Repeatability abs./reading (i.e. accuracy after calibration at this point)
Ansprechzeit T90	< 35 s	Response Time T90

10.3 Technical data: electrochemical sensors

Technische Daten	O2-Long Life #65419	Technische Daten
Elektrochemischer Sensor	O2 Long Life	Electrochemical Sensor
Messbereich	0 .. 21%	Measuring Range
Auflösung	0,01%	Resolution
Genauigkeit abs.	± 0,2 Vol%	Abs. Accuracy
Ansprechzeit T90	< 20s	Response Time T90
Jahre erwartete Lebensdauer an Luft	2	Years expected lifetime (@air)

Elektrochemischer Sensor	H2	Electrochemical Sensor
Nominaler Messbereich	0 - 1 Vol%	Nom. Measuring Range
Überlastbereich	< 2 Vol%	Overload Range
Auflösung	0,01 Vol%	Resolution
Genauigkeit abs. /vom Messwert	0,2 Vol% / 5%	Accuracy abs./reading
Ansprechzeit T90	< 90s	Response Time T90
Jahre erwartete Lebensdauer an Luft	2	Years expected lifetime (@air)

Elektrochemischer Sensor	H2	Electrochemical Sensor
Nominaler Messbereich	0 - 1000 ppm	Nom. Measuring Range
Überlastbereich	< 2000 ppm	Overload Range
Auflösung	1ppm	Resolution
Genauigkeit abs. /vom Messwert	± 10 ppm / 5% (0 ... 1000 ppm) 10% (> 1000 ppm)	Accuracy abs./reading
Ansprechzeit T90	< 110s	Response Time T90
Jahre erwartete Lebensdauer an Luft	2	Years expected lifetime (@air)

Elektrochemischer Sensor	H2S #13705 H2 immune	Electrochemical Sensor
Nominaler Messbereich	0 - 2000 ppm	Nom. Measuring Range
Überlastbereich	< 5000 ppm	Overload Range

Auflösung	1 ppm	Resolution
Genauigkeit abs. /vom Messwert	± 5 ppm / 5% (0 ... 500 ppm), 10% (≥ 500 ppm)	Accuracy abs./reading
Ansprechzeit T90 typisch	< 40s	Response Time T90 typ.
Jahre erwartete Lebensdauer an Luft	2	Years expected lifetime (@air)
keine Querempfindlichkeit auf	100%H ₂ , 100%O ₂ , 100%CO, 100%CO ₂ , 100%N ₂ O	no cross sensitivity at

Elektrochemischer Sensor	H2S #13836 Wide range H ₂ immune	Electrochemical Sensor
Nominaler Messbereich	0 - 5000 ppm	Nom. Measuring Range
Überlastbereich	< 50000 ppm	Overload Range
Auflösung	1 ppm	Resolution
Genauigkeit abs. /vom Messwert	± 5 ppm / 5% (0 ... 5000 ppm), 10% (≥ 5000 ppm)	Accuracy abs./reading
Ansprechzeit T90 typisch	< 60s	Response Time T90 typ.
Jahre erwartete Lebensdauer an Luft	2	Years expected lifetime (@air)
keine Querempfindlichkeit auf	100%H ₂ , 100%O ₂ , 100%CO, 100%CO ₂ , 100%N ₂ O	no cross sensitivity at

Elektrochemischer Sensor	H2S #10479	Electrochemical Sensor
Nominaler Messbereich bei Nutzung der Verdünnung	0 - 2000 ppm	Nom. Measuring Range when using dilution unit
Überlastbereich bei Nutzung der Verdünnung	< 4000 ppm	Overload Range when using dilution unit
Auflösung	1 ppm	Resolution
Genauigkeit abs. /vom Messwert	± 5 ppm / 5% (0 ... 2000 ppm), 10% (≥ 2000 ppm)	Accuracy abs./reading
Ansprechzeit T90	< 40s	Response Time T90
Jahre erwartete Lebensdauer an Luft	2	Years expected lifetime (@air)

Elektrochemischer Sensor	H2S very low #12260 H ₂ immune	Electrochemical Sensor
--------------------------	--	------------------------



Nominaler Messbereich bei Nutzung der Verdünnung	0 - 50 ppm 0 - 2500 ppm	Nom. Measuring Range when using dilution unit
Überlastbereich bei Nutzung der Verdünnung	250 ppm 12500 ppm	Overload Range when using dilution unit
Auflösung	1 ppm	Resolution
Genauigkeit abs. /vom Messwert bei Nutzung der Verdünnung	± 2 ppm / 5% (0 ... 50 ppm) 10% (≥ 50 ppm) ± 5 ppm / 10%	Accuracy abs./reading when using dilution unit
Ansprechzeit T90	40s	Response Time T90
Jahre erwartete Lebensdauer an Luft	2	Years expected lifetime (@air)
keine Querempfindlichkeit auf	100% H ₂ , 100% O ₂ , 100% CO, 100% CO ₂ , 100% N ₂ O	no cross sensitivity at

11 Appendix

The appendix has the follow contents:

- Mechanical drawing
- Gas flow diagram
- Wiring diagram
- Position plan

11.1 Mechanical drawing

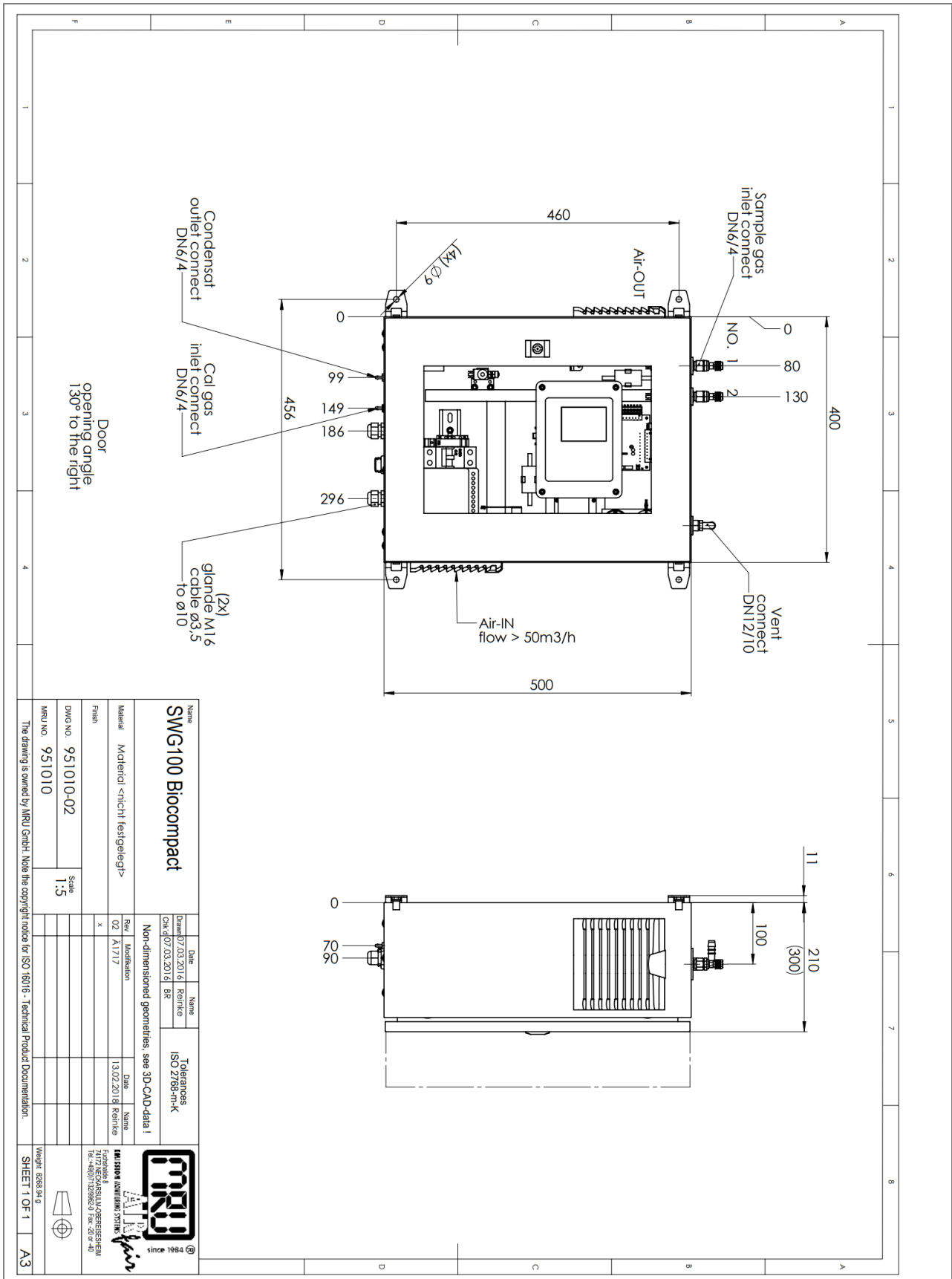

11.2 Gas flow diagram

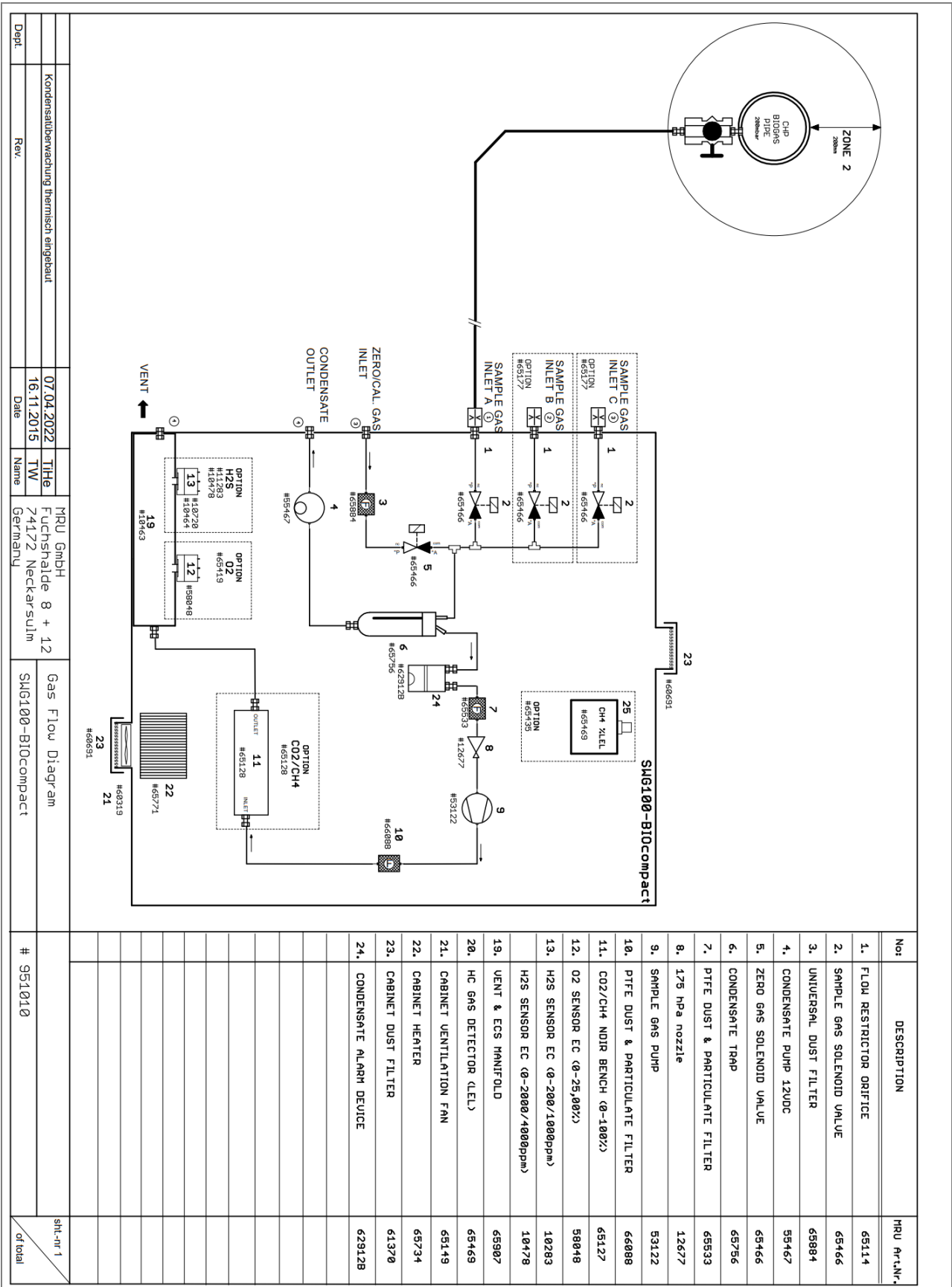

Dept.	Rev.	Date	Name	MRU GmbH Fuchshalde 8 + 12 74172 Neckarsulm Germany	Gas Flow Diagram SMG100-BIOcompact	# 951010
		07.04.2022	TJH			
		16.11.2015	TW			

SHL-nr. 1	of total
-----------	----------

11.3 Wiring diagram

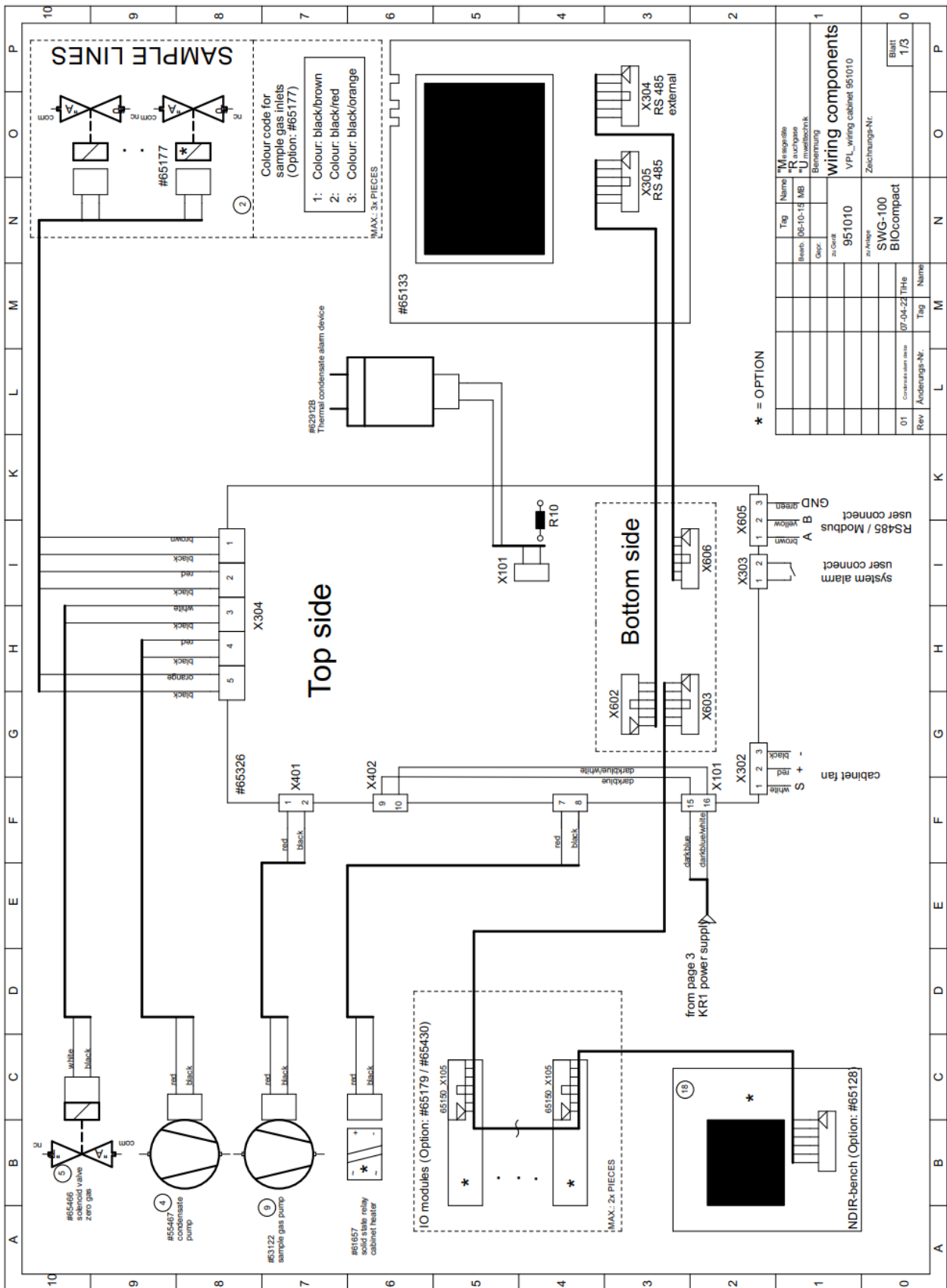

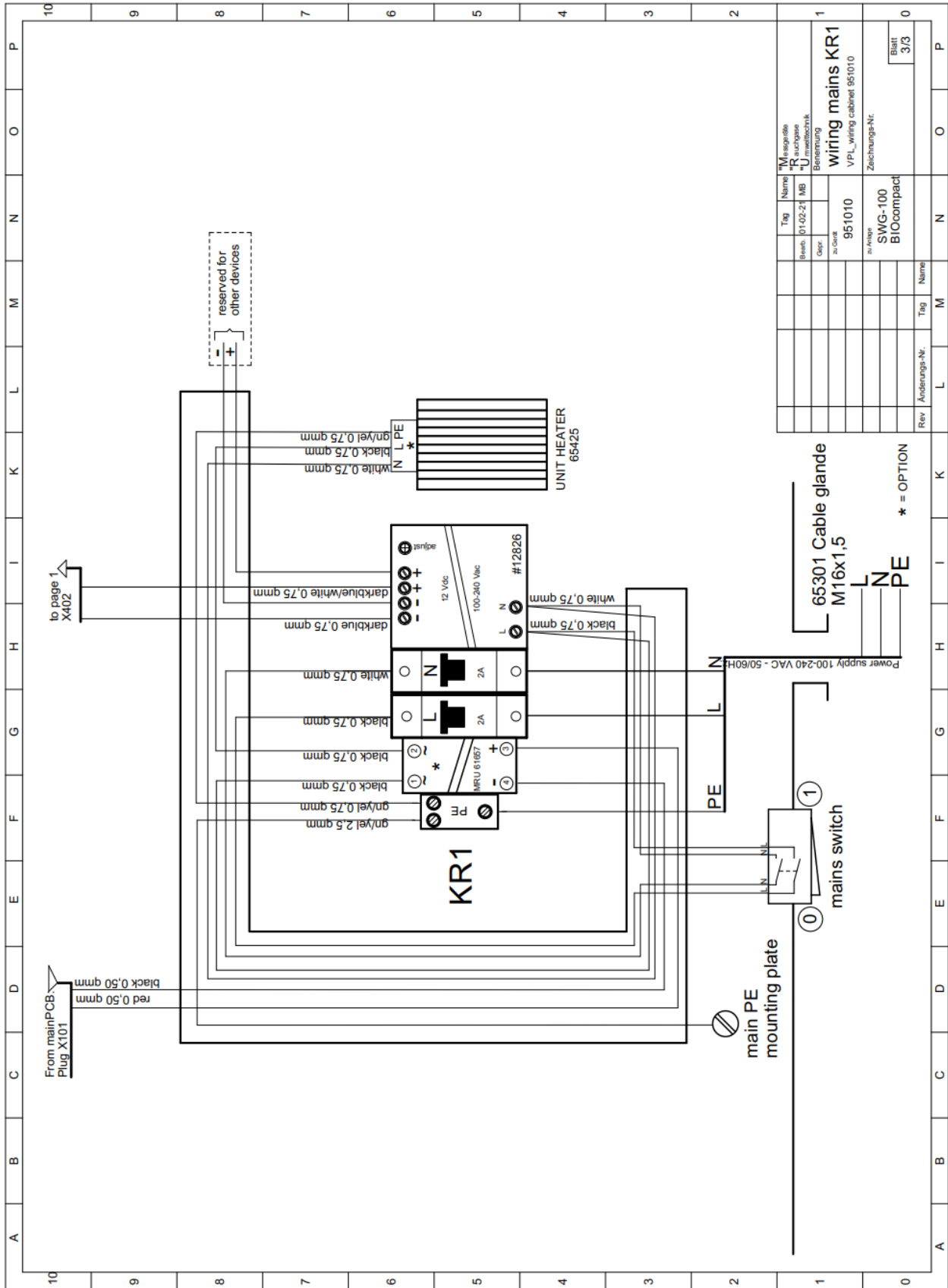

11.4 Position plan

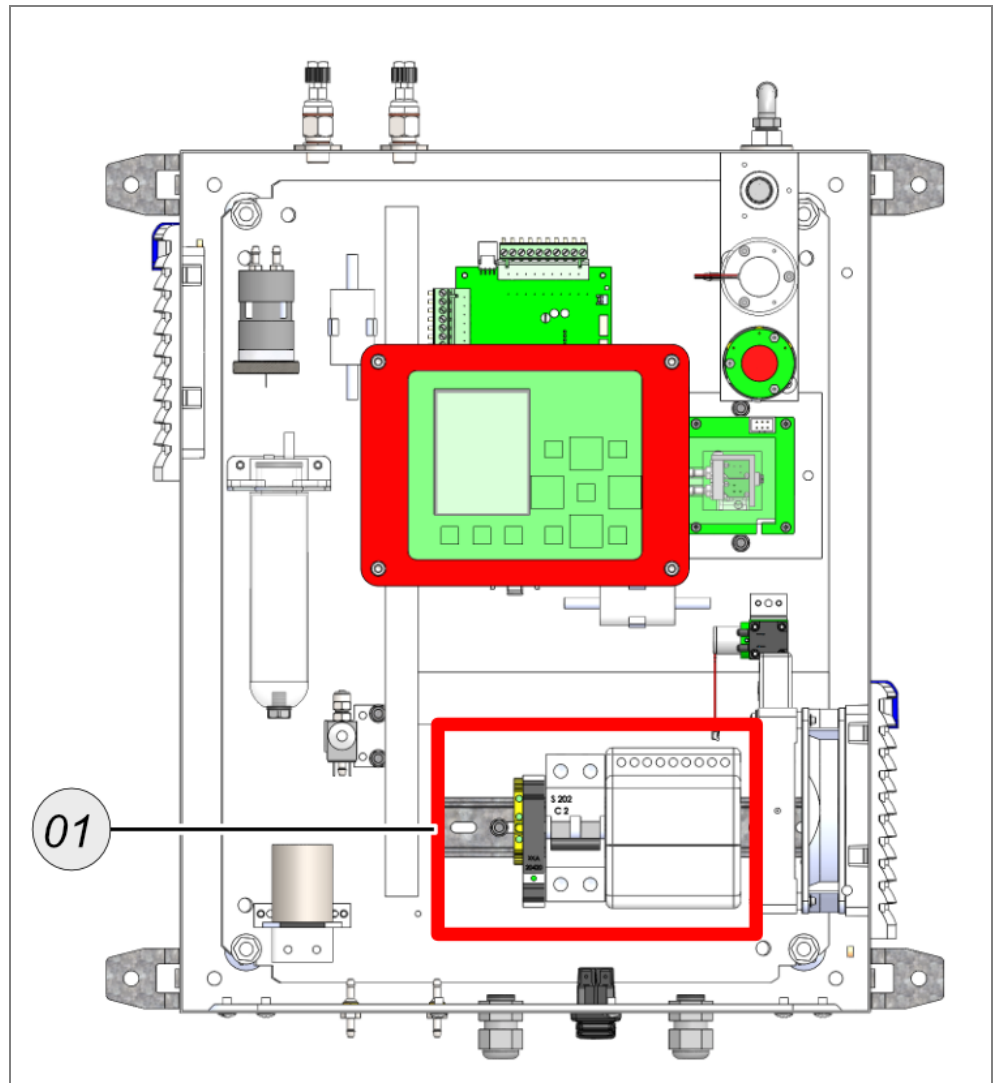

Position	Connection-name	Description
1	X0	Mains