

SWG 200 CEM USER MANUAL



Preamble

This manual includes a description of the product but no guarantees of specific qualities or results of use. Unless otherwise stated, the relevant state of engineering is that at the time of the joint delivery of the product and operating instructions by MRU GmbH.

The design and circuitry are subject to ongoing development and improvement. Subject to technical changes.

This manual is protected by copyright. All rights reserved. Copying, reproduction, translation, or conversion to any type of electronic medium or machine-readable form in its entirety or in parts without the prior written approval by MRU GmbH is not permitted.

Version:

Producer:



MRU · Messgeräte für Rauchgase und Umweltschutz GmbH

Fuchshalde 8 + 12

74172 Neckarsulm-Obereisesheim

Fon 07132 99620 · Fax 07132 996220

info@mru.de · www.mru.eu

Version: 1.0

CONTENT

1	About this manual	7
1.1	Storage location of the manual	7
1.2	General information about the manual	7
1.3	Packaging	7
1.4	Taking back parts containing harmful substances	7
1.5	Taking back electrical equipment	8
1.6	Weather and environmental conditions	8
1.7	General important instructions for the plant operator	9
1.8	MRU Warranty conditions	10
1.9	Representation of safety and warning notes	11
2	Information on the unit and safety	12
2.1	Safety manual	12
2.2	General information	12
2.3	Qualified personnel	13
2.4	Intended use	14
3	Performance description	15
3.1	Configurations and type plate	16
4	Device description	17
4.1	Unit description	17
4.2	Operation unit	18
4.3	Measuring princip	19
5	Installation	21
5.1	General installation rules	21
5.2	Components and terms used	22
5.3	Mounting the device	23
5.3.1	Door distance	24
5.3.2	Dimensions and drilling plan	24
5.4	Connecting power supply	25
5.5	Connecting the vent, condensate outlet and H3PO4 inlet	27
5.6	Mounting the heated sampling line on the sample gas inlet	30
5.7	Connecting the alarm relay	41
5.7.1	Connecting the RS-485 interface	42
5.8	Switching on the unit	43
6	Operation	45
6.1	Operating and display elements	45
6.2	Menu structure	46
6.2.1	Measuring menu structure	47

6.2.2	Open submenu	47
6.3	Setting options Measuring menu	48
6.3.1	Switch to Zoom/Standard display mode	48
6.3.2	Change measurement page	48
6.3.3	Displaying the last Measuring Point Values	49
6.3.4	Configuring the Measurement Window	50
6.4	Menu: Extras	51
6.4.1	General settings	51
6.4.2	Measurement configuration	52
6.4.3	Adjustment menu	52
6.4.4	Factory settings	52
6.4.5	Contents SD card	52
6.4.6	Event viewer	53
6.4.7	Device Info	53
6.4.8	Set the Modbus	54
6.4.9	Set Date & Time	55
6.4.10	Menu: Data-store	56
6.4.11	Calling up the data memory menu	57
6.5	Displaying stored values in text mode	58
6.5.1	Displaying stored values in graphic mode	59
6.5.2	Export measurement to SD card	59
6.5.3	Setting the CSV format	60
7	Setting the measuring cycle	61
7.1	Menu path and basic structure	61
7.1.1	Navigating in the menu	61
7.1.2	Delete Phase	62
7.1.3	Insert phase	62
7.1.4	Insert Autoconfiguration	62
7.2	Phase submenus: Setting options	64
7.2.1	Zeroing (Cycle Phase Details)	64
7.2.2	Measurement SP.x (Cycle Phase Details)	64
7.2.3	Stand by (cycle Phase details)	65
7.2.4	Purging (Cycle Phase Details)	65
7.3	Example for a measurement cycle configuration	66
7.4	Update software	67
7.4.1	Overview: Possible system updates	67
7.4.2	Updating the main unit	68
7.4.3	Updating the different modules	69
8	Service and maintenance	70
8.1	Preparation and instruction for maintenance	70

8.2	Regular maintenance work by the operator	71
8.3	Maintenance parts: Position overview	72
8.3.1	The spare parts set #13430	72
8.3.2	Spare part position outside	73
8.3.3	Spare part position inside	74
8.3.4	Replace filter-mat	76
8.3.5	Replacing the inline filter activated carbon	77
8.3.6	Replacing the inline Sox / NOx filter	78
8.3.7	Replacing the PTFE filter water stop	79
8.3.8	Replacing the PTFE element of the dust filter	80
8.3.9	Replacing the condensate pump hose	81
8.4	Gas adjustment	82
8.4.1	Connect adjustment gas cylinder	83
8.4.2	Adjust Multi Gas Bench	85
8.4.3	Adjust the electrochemical O2-sensor	88
8.4.4	Adjust electrochemical O2 sensor	88
8.4.5	Adjustment electrochemical sensors	91
8.4.6	Adjust paramagnetic O2-sensor	94
9	Option	96
9.1	Option: IO module	96
9.1.1	IO module position	96
9.1.2	Pin assignment	97
9.1.3	Analogue outputs 4-20 mA (AO1-AO4)	99
9.1.4	Alarm Output Setting (AL1-AL2)	100
9.1.5	AUX input for transmitter (AI1-AI4)	101
9.1.6	Set up AUX input	103
9.1.7	Configuration External Control (Option: I/O Module)	104
9.2	Option: Profibus-converter	112
9.2.1	Connect device with Profibus	112
9.2.2	Connection to device	112
9.2.3	Device settings	113
9.2.4	Special information about Modbus-Slave function	113
9.2.5	Special information about Profibus – Slave function	113
9.3	TCP to Modbus RTU Converter	114
9.3.1	Ethernet different states	114
9.3.2	Setting up Ethernet	114
9.4	Option: RS-485 to USB converter	118
9.4.1	RS-485 Converter connection and configuration	118
9.5	Option: auto calibration	120
9.5.1	General warnings	120

9.6	Option: MRU4Win	123
9.6.1	MRU4Win start and settings	123
10	Technical data	125
10.1	General technical data	125
10.2	Technical data: NDIR-bench	126
10.3	Technical data: electrochemical sensors	126
10.3.1	Different measurement techniques	128
11	Appendix	129
11.1	Mechanical drawing	130
11.2	Gas flow diagram	131
11.3	Wiring diagram	132
11.4	Position plan	142
12	Maintenance: Option HD Probe with back-purge	143
12.1	Contents: Spare parts set HD probe SWG #60912-3	144
12.2	HD probe: Replace ceramic filter	145
12.3	HP probe: Replacing the flange seals	147
13	Maintenance: Option HD Probe with back-purge	148
13.1	Contents: Spare parts set HD probe SWG #60912-3	149
13.2	HD probe: Replace ceramic filter	150
13.3	HP probe: Replacing the flange seals	152
13.4	HD-probe dimensions	153

1 About this manual



This manual enable the safe and efficient handling of the product.

The user must read these instructions carefully and understand them before starting work.

The basic prerequisite for safe working is compliance with all the safety manual given.

1.1 Storage location of the manual

The manual is an integral part of the product and must be kept in the immediate vicinity of the product and accessible to personnel at all times.

1.2 General information about the manual

- Read and observe the separately supplied Safety manual.
- This manual enables you to understand and safely operate this MRU Analyser.
- Please read this manual with great vigilant.
- Get familiar with the product before using it.
- This analyser may only be operated by competent personnel and for its intended use.
- The analyser may only be used by qualified personnel for the intended use.
- Please pay special attention to all safety directions and warnings to prevent personal injuries and damaging of the product.
- We cannot be held responsible for any injuries and/or damages that occur by not following the instructions in this manual.
- Always keep the manual near you when working with the analyser, to be able to read instructions as needed. Please ensure to hand over all documents to when handing the analyser over to others.
- Hand over all documents when passing on the analyser to third parties.

1.3 Packaging

Keep the original carton and packaging material to avoid damage in transit in case you have to send the unit to the factory.
to the factory.

1.4 Taking back parts containing harmful substances

MRU GmbH undertakes to take back all parts supplied by us which contain hazardous substances and which cannot be disposed of in the normal way.

Parts containing hazardous substances are, for example, electrochemical sensors, batteries and accumulators.

The return delivery must be free of charge for MRU.

1.5 Taking back electrical equipment

MRU GmbH undertakes to take back for disposal all electrical appliances sold after 13 August 2005. The return of the appliances must be free of charge for MRU.

1.6 Weather and environmental conditions

NOTE

IP class and permissible ambient temperature see technical data.

This degree of protection is only given when the door is closed.

- Protect the inside of the appliance from moisture and dirt.
- Before opening the appliance door, make sure that the external atmosphere is not explosive. To do this, the environment must be measured with a measuring device certified for this purpose.
- The analyser can only be switched on when the door is closed and the purging phase has been completed, or when the unit is in service mode.

1.7 General important instructions for the plant operator

To guarantee continuous operation of the analyser, the functions, processes, and operation of the analyser must be monitored regularly by the plant operator – especially in case of any initial installation. Thus, it will be possible to take suitable measures to improve the availability and lifetime of the analyser.

As the plant operator gains more experience concerning the maintenance requirements of the analyser, the monitoring frequency may be reduced to more extended periods of time.

NOTE

In case of **not intended** use the guarantee will void. Regular controls, inspections and the exchange from polluted and exhausted filters by the operator are also an important part of the determinations “**not determined use**”- see chapter “Maintenance” for regular maintenance work.

1.8 MRU Warranty conditions

The warranty is 12 months.

- 1 The warranty on spare parts is 6 months.
- 2 The term of the warranty conditions starts as of the invoice date.
- 3 The warranty is void under the following conditions:
 - Improper use.
 - Improper application.
 - Improper mounting.
 - Deliberate or negligent destructions.
 - External influence like dropping, impact, solvents, acids, gases, or transport damages. This includes damage, which is caused by exposure to high pollution and/or moisture (condensate) in the gas path.
- 4 As well excluded from the guarantee conditions are typical consumable- and spare parts.
- 5 Use of original MRU consumable parts and sensors is required to maintain the warranty.
- 6 Removal of tampering of the serial number type plate will void the warranty.
- 7 The service of a guarantee conditions will not enlarge the guarantee time. Demands because of consequential damages are excluded.
- 8 MRU is not responsible for the transport costs for the warranty or replacement.
- 9 MRU reserves the right, to determine individual conditions or exceptions. These will be separately communicated.

MRU GmbH

01.09.2014

1.9 Representation of safety and warning notes

Unit-specific safety instructions are placed before dangerous action.

DANGER

Indicates an imminently hazardous situation which, if not avoided, will result in death or serious injury.

WARNING

Indicates an imminently hazardous situation which, if not avoided, could result in death or serious injury.

CAUTION

Indicates a potentially hazardous situation which, if not avoided, may result in minor injury.

ATTENTION

Indicates a harmful situation which, if not avoided, may result in damage to the unit or its surroundings.

NOTE

Identifies user tips and other important information.

 See 8 / Service and maintenance Seite 70

See 8 / Service and maintenance Seite 70

2 Information on the unit and safety

2.1 Safety manual

The safety manual supplied with the unit contains all the general information and safety instructions for the units.

- ! Read and observe the safety manual before the first use of the unit.

2.2 General information

- ! Read and observe separately supplied safety manual
- ! The user manual enables you to operate the unit safely.
- ! Read the user manual carefully.
- ! Get familiar with the unit before you use it.
- ! Before turning on the unit, carry out an overall visual inspection of the unit, the gas sampling probe and any attachments.
- ! Do not operate the unit if there is any damage to the housing, power supply unit, supply cables or other damage.
- ! Operate the unit only with the supplied power supply adapter.
- ! Do not use the metal tube of the gas sampling probe or other metallic parts as electrical conductors.
- ! Do not exceed the specified temperature range of the gas sampling probe. The temperature sensor and probe tube will be destroyed if the temperature range is exceeded.
- ! The unit may only be used by qualified personnel for the intended use.
- ! Operate the unit only within the parameters specified in the technical data.
- ! Do not use any violence.
- ! Only carry out maintenance and servicing work described in the user manual. Observe the specified action steps. Only use original spare parts.
- ! Do not store the unit together with solvents, acids or other aggressive substances.
- ! Keep this user manual close at hand so that you can refer to it whenever necessary.

- ! Ensure to hand over all documents to when handing the unit over to others.

2.3 Qualified personnel

⚠ WARNING

Qualified personnel

The units may only be installed and commissioned by qualified and competent personnel.

For the purposes of these instructions, qualified personnel are persons who are familiar with the installation, commissioning and operation of this product and who have qualifications appropriate to their work, such as:

- ! Training or instruction or authorisation to install circuits and devices or systems and systems in accordance with the current standards of safety technology, to earth and and mark them.
- ! Training or instruction in accordance with current safety engineering standards in Care and use of appropriate safety equipment.
- ! Training in first aid.

2.4 Intended use

DANGER

Risk of explosion in explosive atmospheres

There is a risk of explosion in explosive atmospheres.

- The measuring device is approved only for use in nonexplosive atmospheres.

The unit is a gas analyser with which emission values for various gases can be determined. Mainly typical combustion gases and their concentrations are determined with the device. These can be e.g. CO₂, CO and O₂.

The gas components are detected with different measurement sensors, such as NDIR technology, electrochemical sensors, heat conduction detectors or paramagnetic sensors.

The device must not be used for personal protection. The device is not a substitute for prescribed safety devices.

The warranty becomes void if the device is not used for its intended purpose.

Regular checks, inspections and replacement of dirty and used filters by the operator of the unit also fall under the provision "improper use" - see chapter "Regular maintenance by the operator".

👉 See 8 / Service and maintenance Seite 70

3 Performance description

The SWG200-CEM is a stationary gas analysis system for continuous emission monitoring.

It is intended for clean applications, these can be exemplified by:

- clean flue gases / exhaust gases / exhaust emission points,
- natural gas, biogas and diesel units and CHP plants,
- methane/natural gas boilers and steam power plants,
- iron and steel furnaces, surface treatment, process heaters,
- gas turbines, gas-fired power plants and purified power plants.

A defined gas flow is extracted, filtered and further processed by a measuring probe.

Depending on the configuration, the gas analyser can measure the following gas components:

- Carbon monoxide (CO)
- carbon dioxide (CO₂)
- Nitrogen monoxide (NO)
- nitrogen dioxide (NO₂)
- Sulphur dioxide (SO₂)
- Oxygen (O₂)
- Methane (CH₄)
- Propane (C₃H₈)

Depending on the configuration, different measurement principles can be used in your unit to determine the gas concentrations.

These can be exemplary

- NDIR measuring cells,
- paramagnetic sensors,
- thermal conductivity sensors.

3.1 Configurations and type plate

You can read the respective configuration of your unit on the type plate.

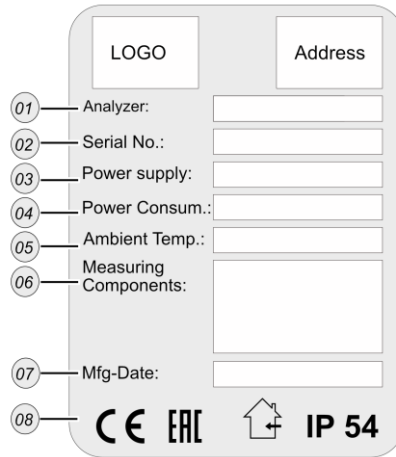

Number	Description
1	Product name
2	Serial number
3	Power supply
4	Electrical power
5	Permissible ambient temperature
6	Detectable sample gases and their measuring ranges
7	Manufacturer's date
8	Markings here as example

4 Device description

4.1 Unit description

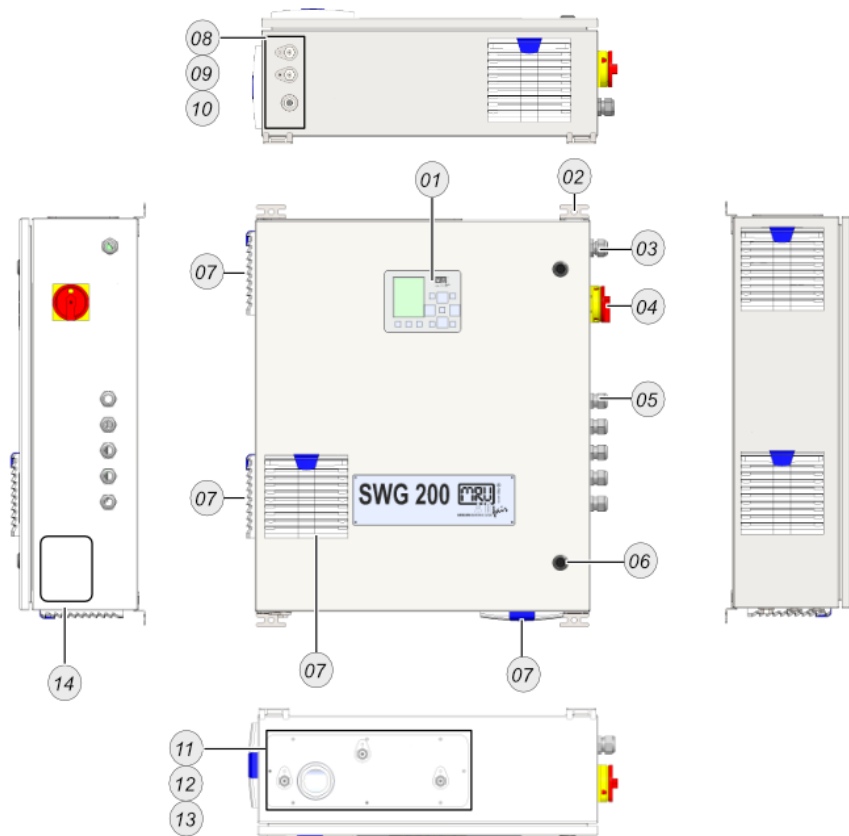

#	Description	#	Description
1	Operation unit	10	H3PO4 inlet*
2	Wall hanging	11	Zero gas inlet*
3	M32 Gland for mains	12	Calibration gas inlet*
4	Main switch	13	Sample gas inlet*
5	M12 Glands for Modules	14	Type plate
6	Lock		
7	Filter-unit		
8	Condensate outlet*		
9	Vent**		

*The positions of the inlets and outlets are printed on the unit. All inlets and outlets have a G1/8 inner thread.

**The position of the vent is printed on the unit. The vent has a G1/4 inner thread.

4.2 Operation unit

The control unit is used to operate the unit. In addition, the SD card slot is located on the back of the control unit.

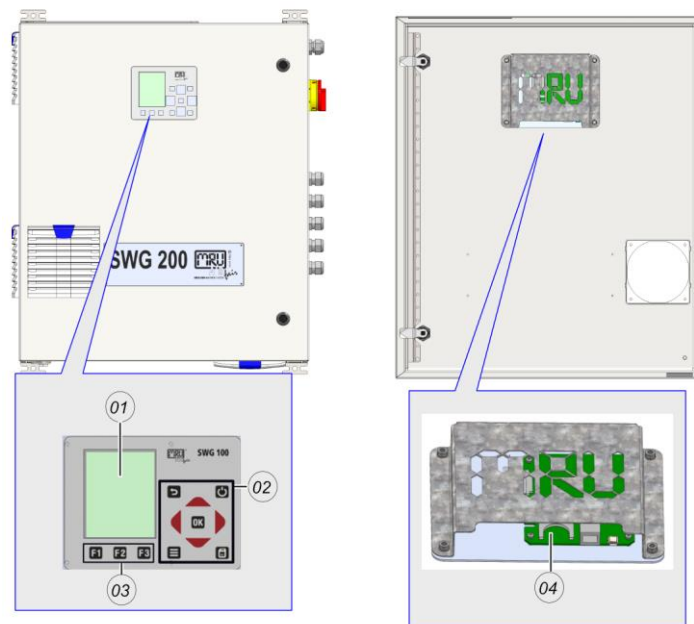

#	Description
1	TFT-Display
2	Control-keys
3	Function keys
5	SD-card slot.

4.3 Measuring princip

In general, the unit works according to the following measuring principle.

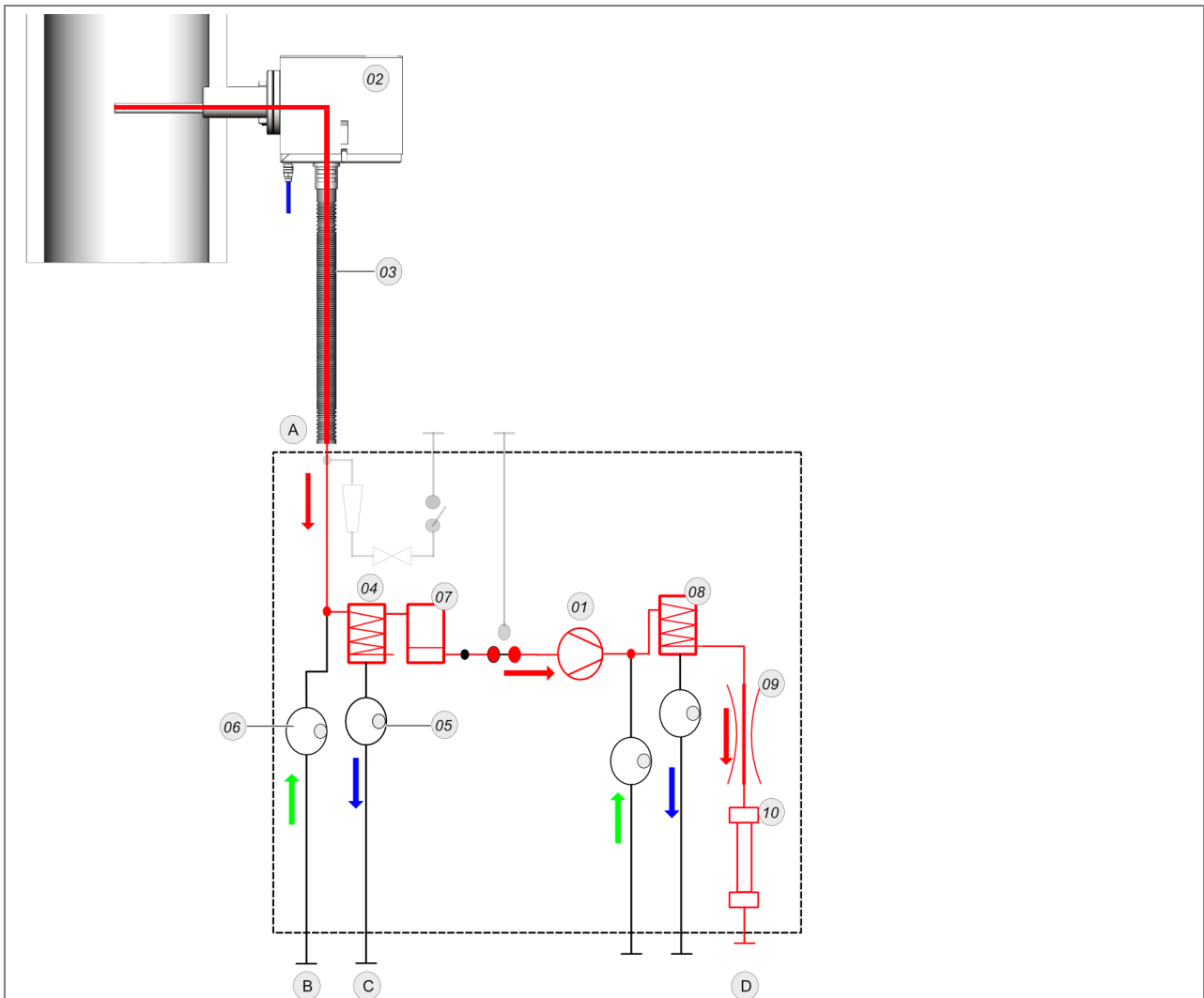

#	Description	Default settings	#	Description	Default settings
1	Sample gas pump	---	10	Gas measurement unit	
2	Sample gas probe	160°C	A	Sample gas inlet	
3	Heated sampling line	160°C	B	H3PO4 inlet	
4	Gascooler unit	20°C dew point	C	Condensate outlet	
5	Condensate pump	14 ml/ min	D	Vent	
6	Phosphoric acid pump	1 ml/h H3PO4			
7	Gas-filter	---			
8	Gascooler unit	5°C dew point			
9	Flow control	50l/h			
10		---			

- With the help of a sample gas pump **01**, the sample gas is sucked into the device via a heating sample gas probe **02** and a heating sample line **03**. The heated measuring section prevents the sample gas from condensing out.
- In the unit, the sample gas is first pre-dried to a dew point of 20°C. This is done with the help of the first gas cooler **04**. The moisture precipitates and is transported out of the unit by a condensate pump **05**.
- By dripping a 10 vol% phosphoric acid solution **06** into the gas cooler, certain water-soluble gas components, such as SO₂ and NO₂, are prevented from being washed out.
- The pre-dried sample gas can now be cleaned of particles by a PTFE filter **07** without the filter becoming clogged.
- In the second gas cooler **08**, the sample gas is dried to a dew point of 5°C.
- The cleaned and dry sample gas enters the measuring equipment **09** via a measuring cannula.
- Depending on the options, the measuring equipment **10** can be different NDIR cells, electrochemical sensors or thermal conductivity sensors.

5 Installation

You will learn how to assemble and install the device correctly. The installation work includes:

- Set up the device,
- Wire the unit electrically,
- Connect the tubing to the unit,
- Connect the sampling line.

5.1 General installation rules

For outdoor installation, mount the unit in a rain-protected and sun-protected location.

NOTE

If necessary, fit a rain and sun roof over the unit.

For indoor installation, mount the unit in a clean and dry place. Ensure that the room is constantly ventilated with fresh air.

Other general rules are:

- Mount the unit on a solid wall or steel beam.
- Make sure that the air circulation is not obstructed.
- Provide sufficient space for the piping.

5.2 Components and terms used

The components and the terms used are presented here. You will need these components for on-site installation.

#	Description	#	Description
1	HD-probe	2	DN4/6 mm Filter-nozzle unit
1.1	DN65 Graphite seal	3	1/8G Zero-gas-filter
1.2	M12-bolt	4	DN10/12 mm vent-fitting
1.3	M12-Threadlocker	5	DN4/6 mm-H3PO4-fitting
1.4	M12-washer	6	DN4/6 mm-condensate-fitting
1.5	M12-nut	7	H3PO4-canister
1.6	HD-probe	8	DN4/6 mm-Support sleeve
1.7	Probe sealing	9	HD-heated sampling line

1	1.1	1.2	1.3
			
1.4	1.5	1.6	1.7
			
2	3	4	5
			
6	7	8	9
			

5.3 Mounting the device

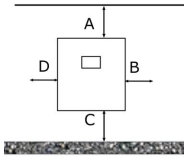

CAUTION

Risk from a net weight greater than 10 kg
 This may result in overloads or crush injuries.

- Move the measuring device with appropriate caution.

Your unit is designed as a wall-mounted housing. For installation, you must mount the wall-mounted enclosure on a stable wall using four M12 bolts (strength class: 8.8).

A suitable installation location must meet the following criteria:

- The installation location should be protected from direct sunlight.
- The installation site should be protected from direct rain.
- The installation site should be easily accessible.
- The installation site should be well ventilated.
- The installation site should have enough space for installation and operation.

ATTENTION

Keep attention to the minimum distance.

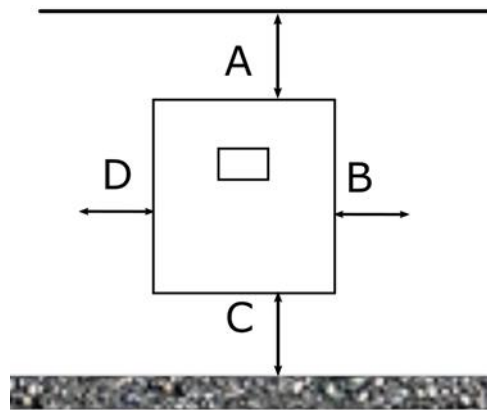

Position	Description
A	Min. 500 mm
B	Min. 300 mm
C	Min. 1000 mm
D	Min. 300 mm

5.3.1 Door distance

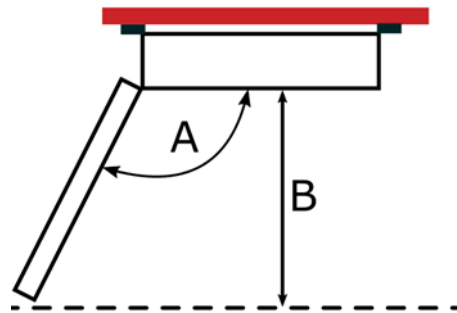

Position	Description
A	120°-180° depending on the type of device
B	Min. 1000 mm. Door hinges are on the right.

5.3.2 Dimensions and drilling plan

Wallmounting with:

- 4xM12 screws with strength class 8.8.
- 👉 See 11.3 / Wiring diagram Seite 132

5.4 Connecting power supply

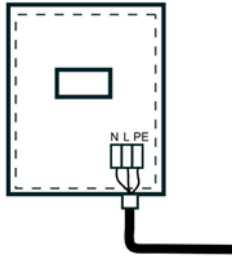

Connect the power supply to terminal block X-0.

This section tells you where to connect the power supply.

- See 11.3 / Wiring diagram Seite 132
- See also Position plan, page 142

⚠ WARNING

Risk of serious damage to property and personal injury due to improper electrical installation.

Safe electrical installation can only be guaranteed if the person carrying out the installation has proven knowledge in the following areas:

- Connection to the installation network.
- Connection of several electrical appliances.
- Laying electrical cables.
- As a rule, only trained specialists in the field of electrical installation technology have this knowledge and experience. If these minimum requirements are not met or disregarded, you may be personally liable for damage to property or personal injury.

⚠ WARNING

Country-special electrical installation requirements

Find out about your country-specific requirements for additional electrical protection devices.

PREQUESTION

- A suitable 3-core installation cable with PE, L and N conductors, with a cross-section of 1.5 mm² must be available.
- The unit is designed for 100 - 230 VAC / 47 - 60 Hz.
- The terminal block for the voltage is marked X-0.

STEPS

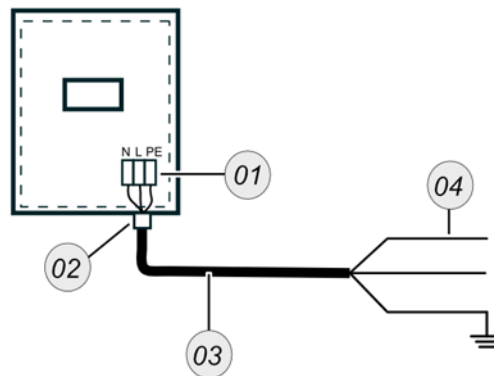

#	Description
1	Terminal block
2	Cable gland „Mains“
3	Core installation cable
4	Cable core L,N,PE

Fig.1

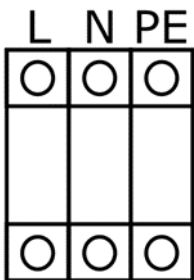

Terminal block X-0 for power supply.

- Route 3-wire installation cables through the "Main supply" cable gland (Fig.1 (2)).
- Find the terminal block X-0. On this block the 3-wire cable is installed (Fig1. (1)).
- Connect the PE conductor to the PE terminal.
- Connect the L conductor to the L terminal.
- Connect the N conductor to the N terminal.

You have installed the power supply.

See 11.3 / Wiring diagram Seite 132

5.5 Connecting the vent, condensate outlet and H₃PO₄ inlet

⚠ DANGER

Risk due to toxic gases

Noxious gases are sucked in by the measuring device and released into the ambient air.

- Only use the measuring device in well ventilated spaces.
- Always connect a hose to the vent.
- Always lead the hose into an area that is empty of people.

⚠ CAUTION

Acid from the condensate

Acid burns may result from weakly acidic liquids from the condensate.

- If you come into contact with acid, wash the area immediately using a lot of water.
- Note the safety data sheet for phosphoric acid (10%)

⚠ CAUTION

Chemical burns from H₃PO₄ acid

Acid burns may result from weakly acidic liquids from the 10 vol.% H₃PO₄.

- If you come into contact with acid, wash the area immediately using a lot of water.
- Always wear protection glasses.
- Note the safety data sheet for phosphoric acid (10%)

In this chapter you learn how to install and connect the right fittings on the vent, condensate outlet and the H₃PO₄ inlet.

👉 See in appendix X-X for the right position.

REQUIRED COMPONENTS

- Condensate connection DN4/6 mm (Fig1 (2))
- Phosphoric acid connection DN4/6 mm (Fig1 (1))
- Phosphoric acid canister
- Vent connection DN10/12 mm (Fig.1 (3))

STEPS: INSTALL FITTINGS

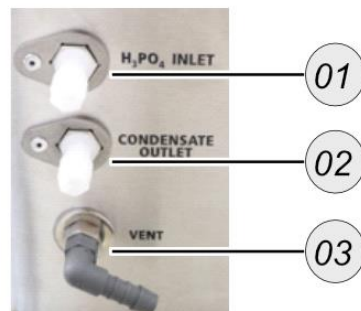

Fig. 1

NOTE

Seal all threads with a PTFE tape.

- Screw the condensate connection DN4/6 mm hand-tight into the Condensate Inlet (Fig.1 (2)).
- Screw the phosphoric acid connection DN4/6 mm hand-tight into the H₃PO₄ inlet (Fig.1 (1)).
- Screw the DN10/12 mm vent connection hand-tight into the vent (Fig.1 (3)).

The fittings are mounted.

STEPS: CONNECT THE HOSES ON THE FITTINGS

ATTENTION – Acid from condensate. Acid burns may result from weakly acidic liquids from the condensate.

- Connect a DN4/6 mm hose to the condensate outlet and lead the hose into a condensate container.

⚠ DANGER – Risk due to toxic gases. Noxious gases are sucked in by the measuring device and released into the ambient air.

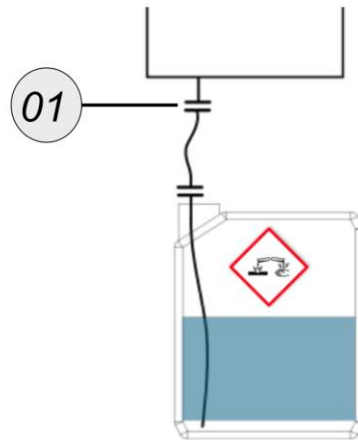

Fig. 2

- ▶ Connect the phosphoric acid canister to the H₃PO₄ Inlet (Fig. 2).
- ▲ **CAUTION** – Chemical burns from H₃PO₄ acid. Acid burns may result from weakly acidic liquids from the 10 vol.% H₃PO₄.
- ▶ Fill the phosphoric acid canister with 10% phosphoric acid by volume.
- ▶ Connect the hose of the phosphoric acid canister to the PTFE fitting.
- ✓ The vent is mounted.
- ✓ The phosphoric acid canister is mounted.
- ✓ The condensate outlet is mounted.

5.6 Mounting the heated sampling line on the sample gas inlet

⚠ DANGER

Fire hazard

Unrolled heated sampling line heats up and can catch fire. Burns can lead to death.

- Always unroll the heated sampling line.

⚠ WARNING

Risk of electric shock from the power system voltage

This may result in severe injuries or death.

- Do not connect or disconnect power cables or power supplies with wet hands.
- Do not use any cables that have been damaged by pulling, twisting, being tied together, or extreme bending.
- Do not connect to an outlet where several devices have already been connected using power strips or that has been extended several times using extension cords:

⚠ WARNING

Risk due to compressed air

This may result in injuries.

- <Connection with the specifications in the operating instructions.
- Depressurize the system before assembly installation or removal.

In this chapter you learn how to install the heated sampling line and the HD-probe with the device. The sketch below gives you a short introduction of the entire installation process.

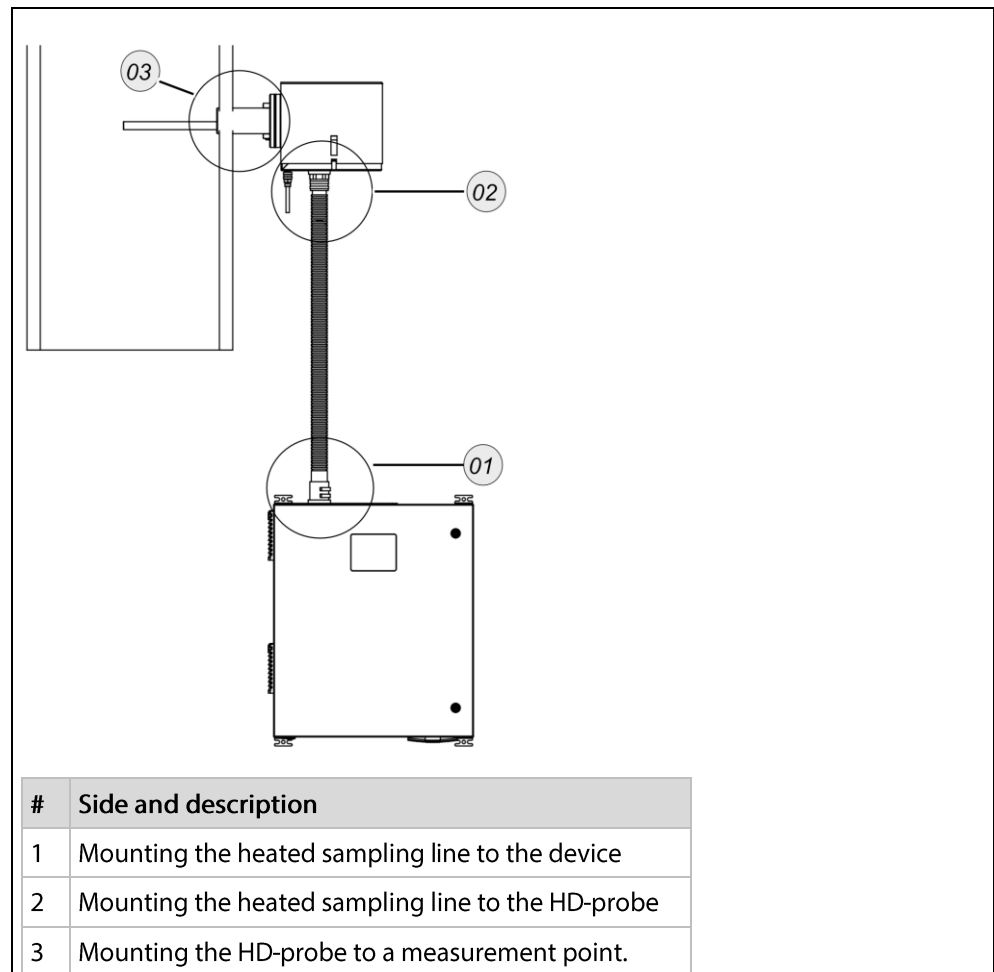

PREREQUISITE

- HD heated sampling line
- HD probe
- 1x support sleeves
- HD probe tube
- HD probe tube seal
- Female couple NS7,2 for compressed air connection

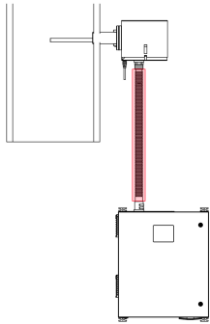

STEPS: UNROLL THE HEATED SAMPLING LINE

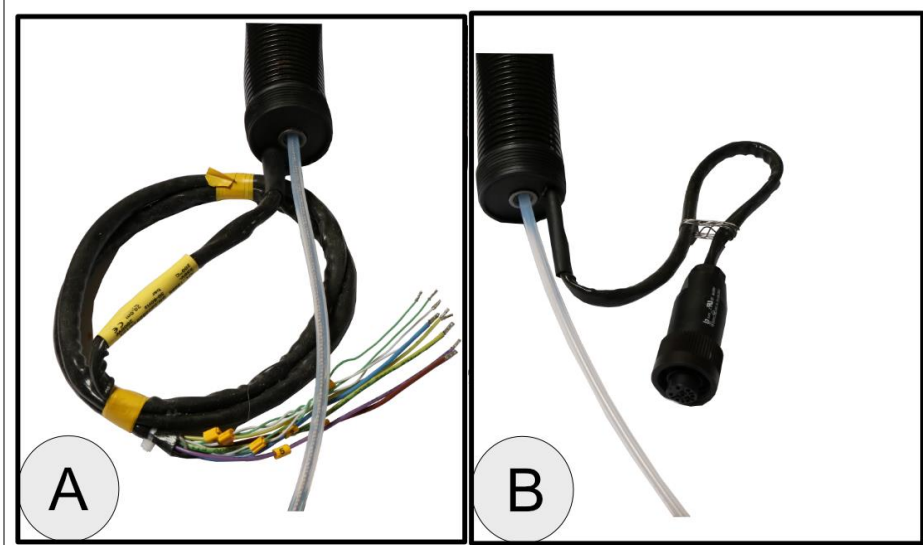

#	Side
A	To device
B	To HD-probe

Fig 1

⚠ DANGER – Fire hazard. Unroll the heated sampling line, before use it.

▶ Unroll the heating sampling line.

The 2 ends of the heated sampling line appears.

One side is for the device installation. This side has a harness (Fig1. A).

One side is for the prob installation. This side has a plug (Fig. (B))

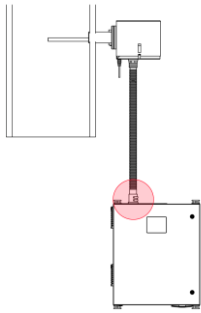

STEPS: MOUNTED HEADED SAMPLING LINE IN DEVICE (SIDE A)

- ▶ Insert *side A* of the heated sampling line into the *Sample gas Inlet* of the device.

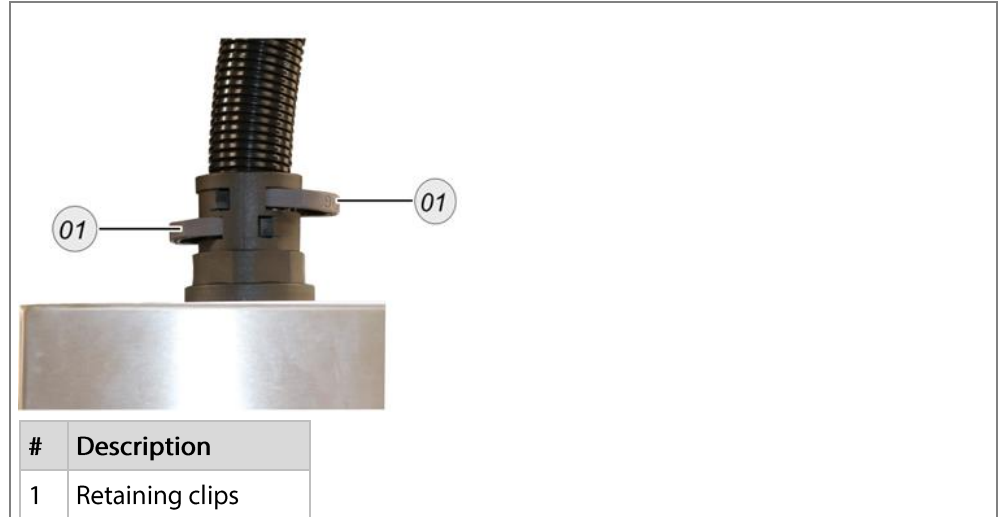

Fig.2

- ▶ Press the retaining clips of the heated sampling line adapter together (Fig.2 (1)).

The heating hose is fixed.

⚠ WARNING – Fire hazard. Wire the harness correctly. Wrong wiring cause fire.

▶ Wire the wiring harness to the X1 terminal Fig. 3).

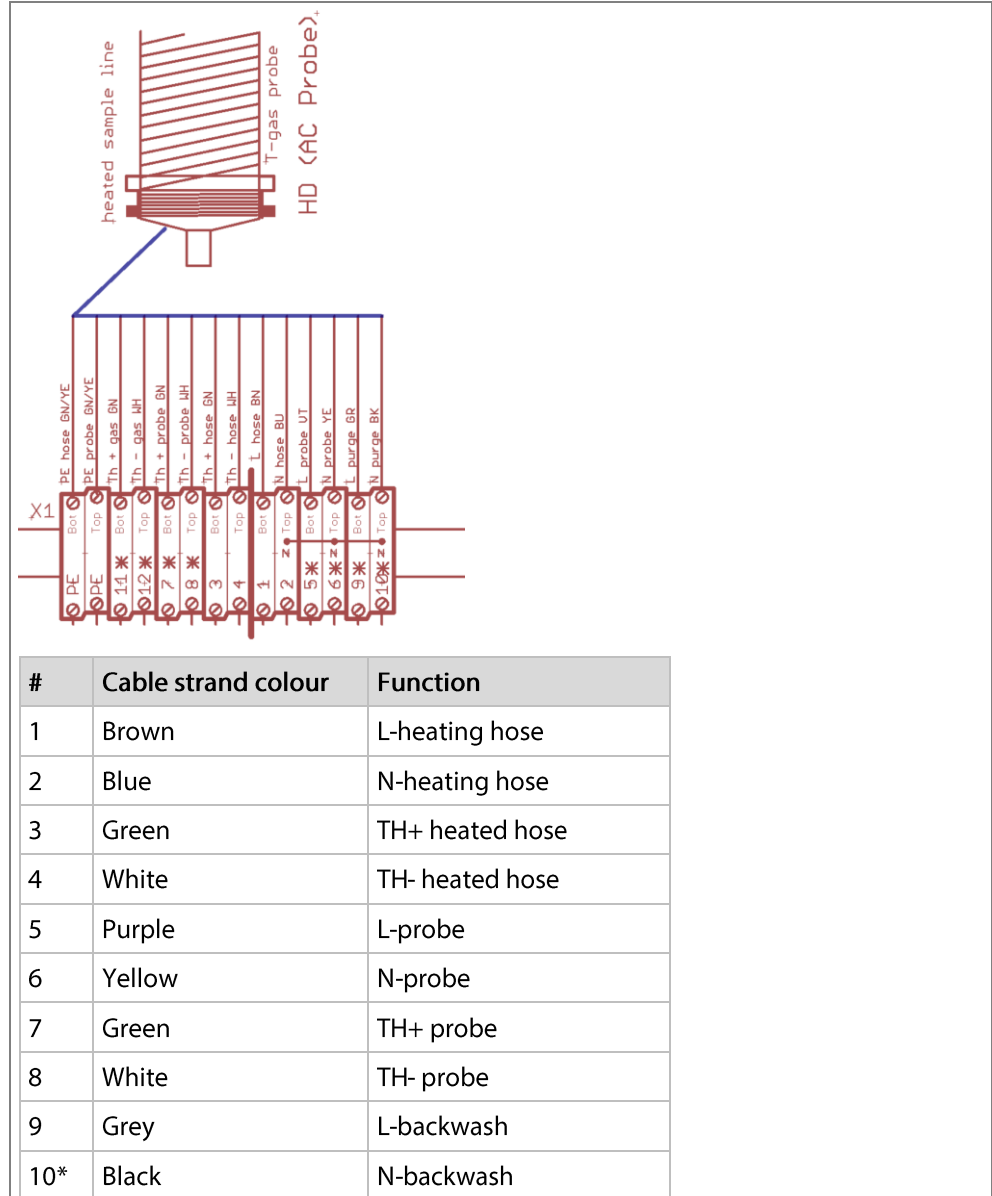

Fig. 3

👉 See appendix X-X for wiring diagram.

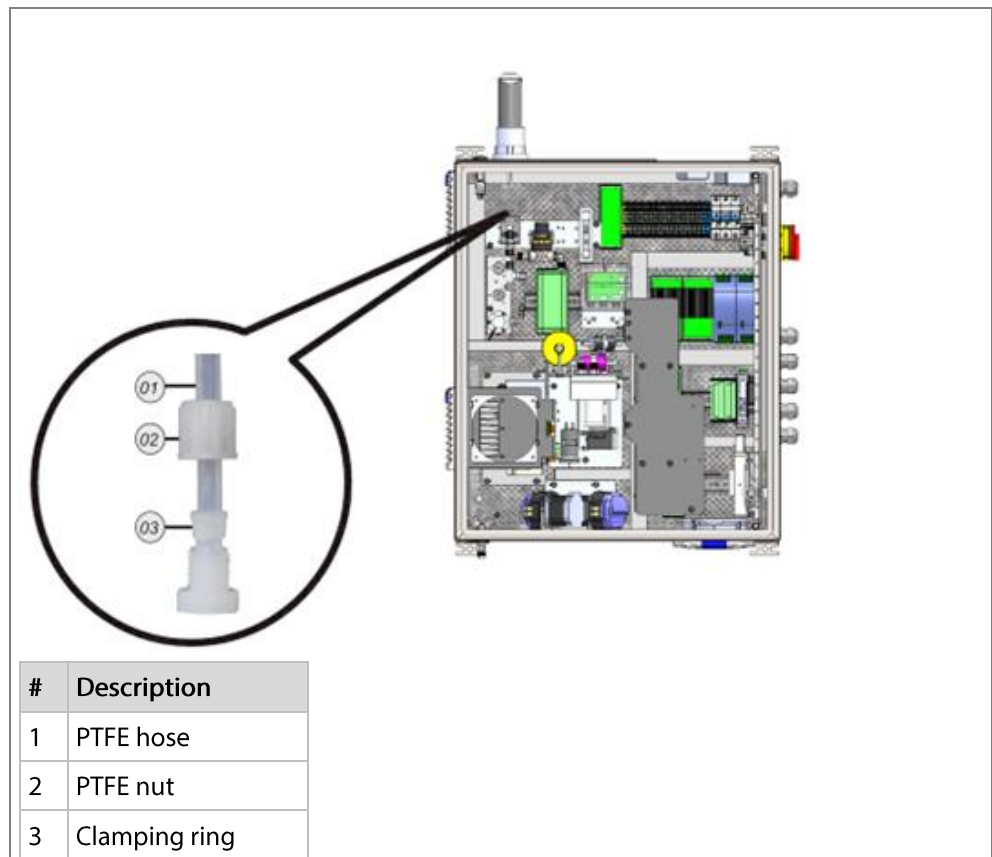

Fig.4

- ▶ Connect the PTFE hose to the gas inlet (Fig.3).
- ✓ Side A is ready mounted.

STEPS: MOUNTED HEATED SAMPLING LINE TO HD-PROBE (SIDE B)

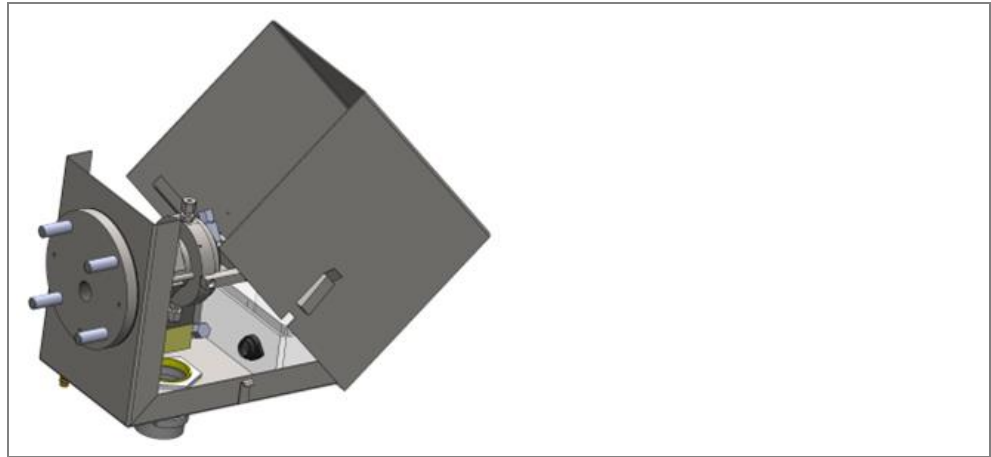
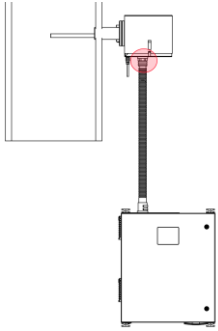

Fig.5

▶ Open the cover of the HD-probe (Fig.4).



Fig. 6

▶ Insert side B of the heated hose into the HD probe inlet (Fig. 5).

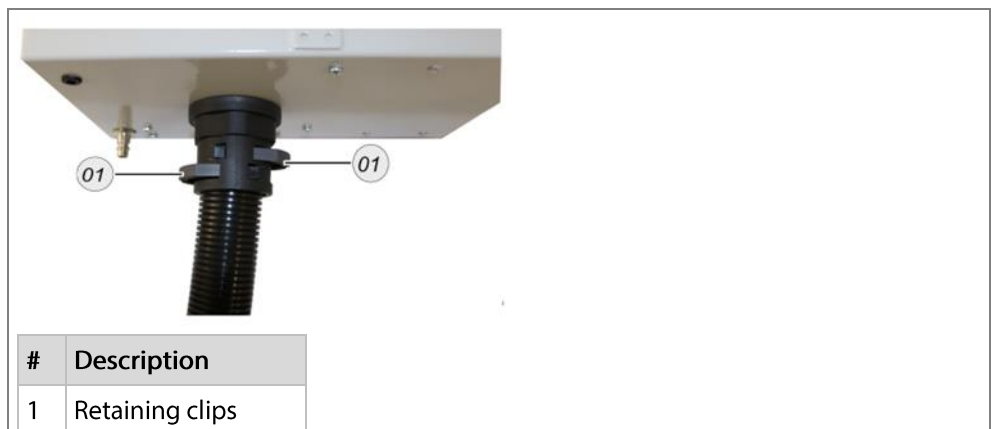

Fig. 7

▶ Press the retaining clips of the heated hose adapter together (Fig. 6 (1)).

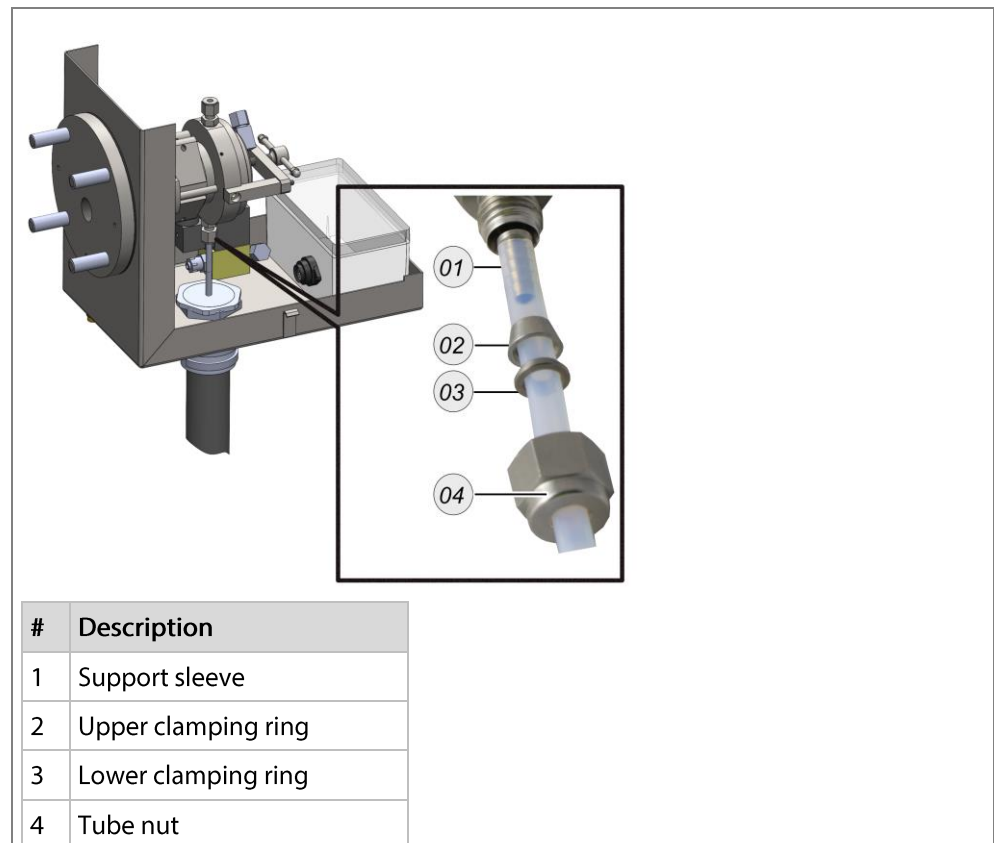

Fig. 8

- ▶ Connect the PTFE hose to the tube fittings (Fig. 7 (1-4)).
- ▶ Install the PTFE hose to the sample gas outlet of the HD-Probe (Fig. 7).

NOTE

To ensure that the tube fitting is properly tight, turn the tube nut 04 with a spanner SW 18 one and a half times.

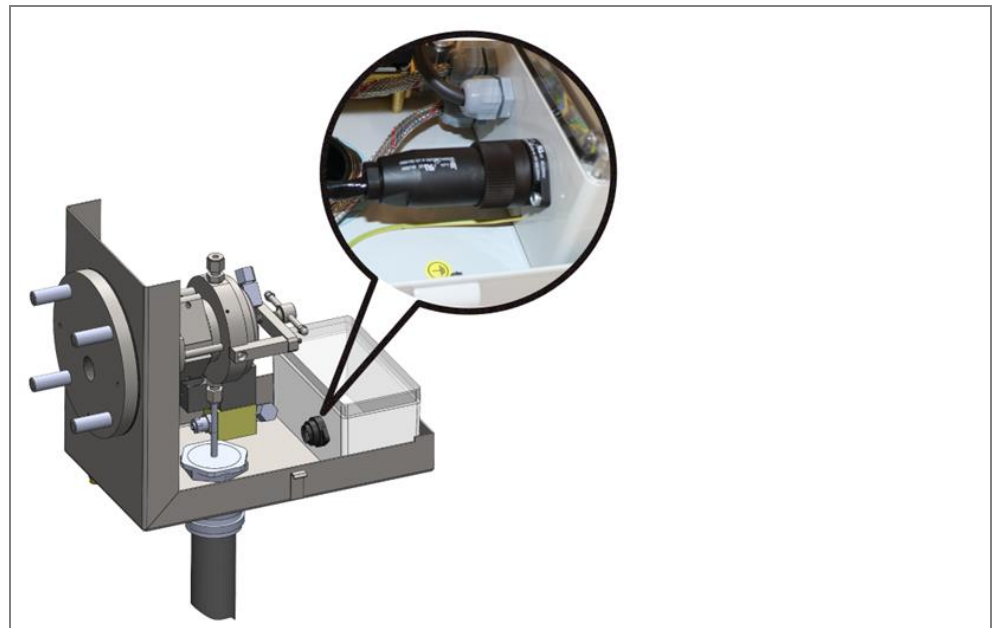
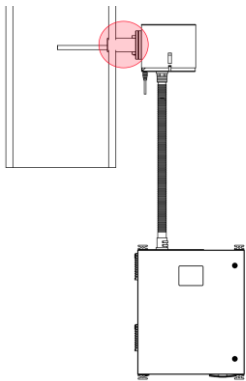

Fig. 9

- ▶ Insert the probe plug into the probe socket (Fig. 8)
- ▶ Close the cover of the HP probe.
- ✓ You have mounted the heating hose with the probe and the unit.



STEPS: MOUNTING THE ADAPTER FLANGE

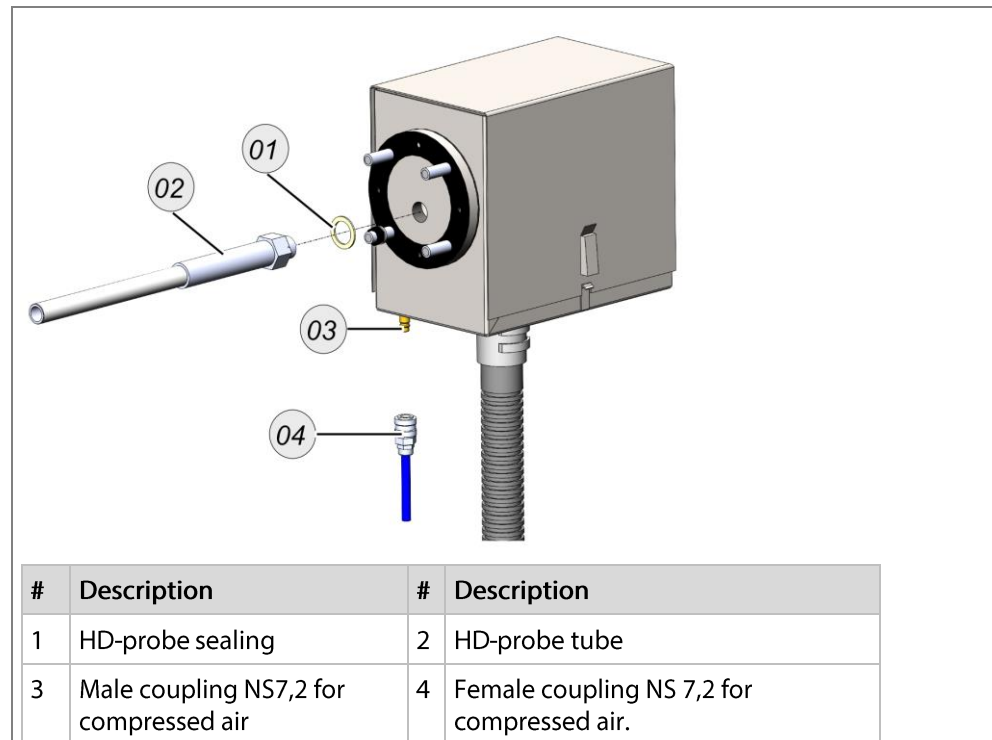

Fig. 1

👉 Technical data about the pressure quality and value, see appendix.

▶ Bring the HD-probe tube sealing on the probe-tube.

⚠ WARNING – High pressure. Pressure can cause injuries and death. Only qualified personnel may connect compressed air.

⚠ WARNING – Do not exceed pressure range. The device is constructed for a pressure range of 0,6 to 0,8 MPa.

▶ Install a female coupling NS 7,2 for Compressed air connection.

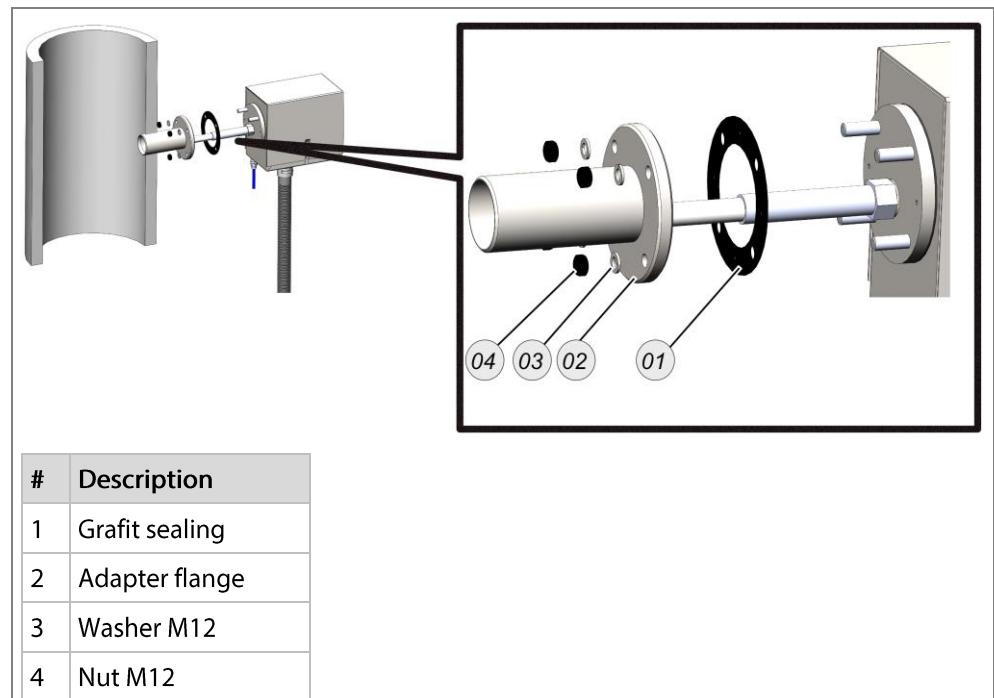

Fig. 2

- ▶ Screw the probe-tube on the HD-probe.
- ▶ Mount the HD-probe on the adapter flange.

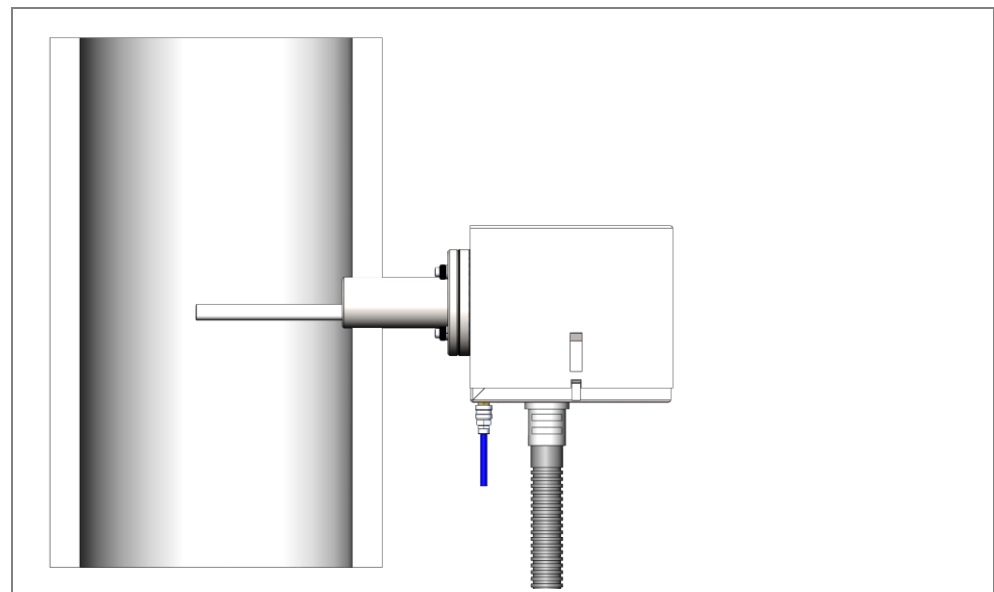

Fig. 3

- ✓ The HD-probe is mounted.

5.7 Connecting the alarm relay



The alarm relay is marked
ALARM.

Your unit has an alarm relay. The alarm relay is triggered when a system alarm is triggered in the unit.

PREREQUISITE

- i The alarm relay is marked "Alarm" in the control cabinet.
- i The alarm relay is tightened during operation.
- See in the appendix X-X for position of device.
- See in the appendix X-X for Modbus protocol and different alarms.

STEPS

- Wire to Connection 14 (Normally open).
- Wire to Connection 11 (COM).
- The alarm relay is connected.

5.7.1 Connecting the RS-485 interface



BUS module with RS-485 interface

The unit has an RS-485 interface. You have the option of retrieving different data via Modbus (RTU). You will find the RS-485 interface connection on the BUS module, inside the unit.

PREREQUISITE

- i The RS-485 interface is marked with X-X.
- 🔗 See in appendix X-X to find position of the device.

STEPS

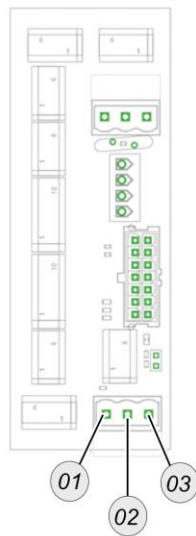

#	Description
1	GND
2	B_EXT-
3	A_EXT+

Fig.1

- ▶ Assign the RS-485 connector (Fig.1 (1-3)).

5.8 Switching on the unit

Here you will find out to switch on the main switch.

STEPS:

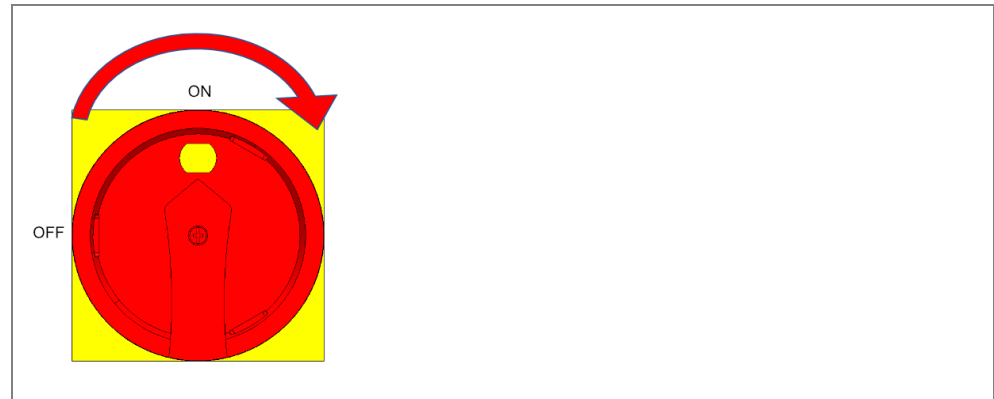

Fig. 1

- ▶ Turn the main switch to the "ON" position (Fig.1).

The boot process is started. The boot process takes about 15 seconds.

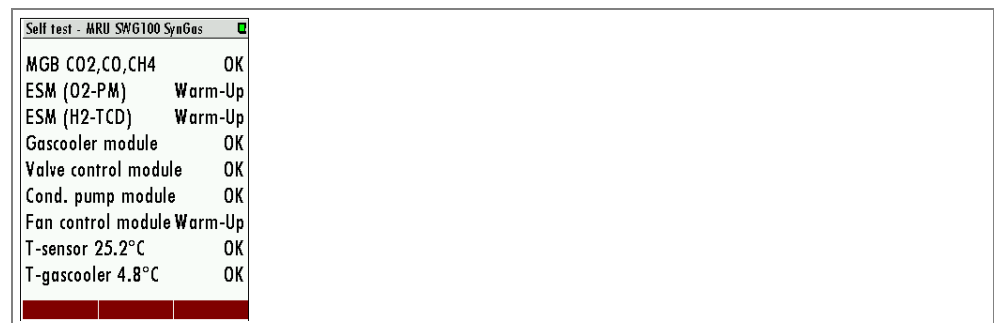

Fig. 2

The self-test is started (Fig. 2).

- ▶ Wait until the self-test is finished. Dependent from the options this may take longer.

NOTE

After the self test is finished, the device makes the follow steps automatically.



Fig. 3

The main measurement window appears. The grey background means that the measurement mode is not active (Fig. 3).

The first zero point measurement is started.

- ▶ Wait until the unit has completed the first purging phase and zeroing. This process takes about 5 minutes.

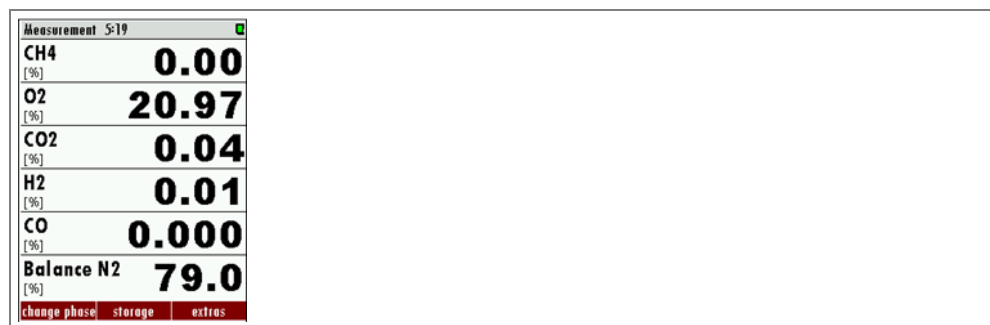

Fig. 4

The unit goes into measuring mode. You can recognise this by the white background (Fig. 4).

- ✓ The unit is ready to measure.

6 Operation





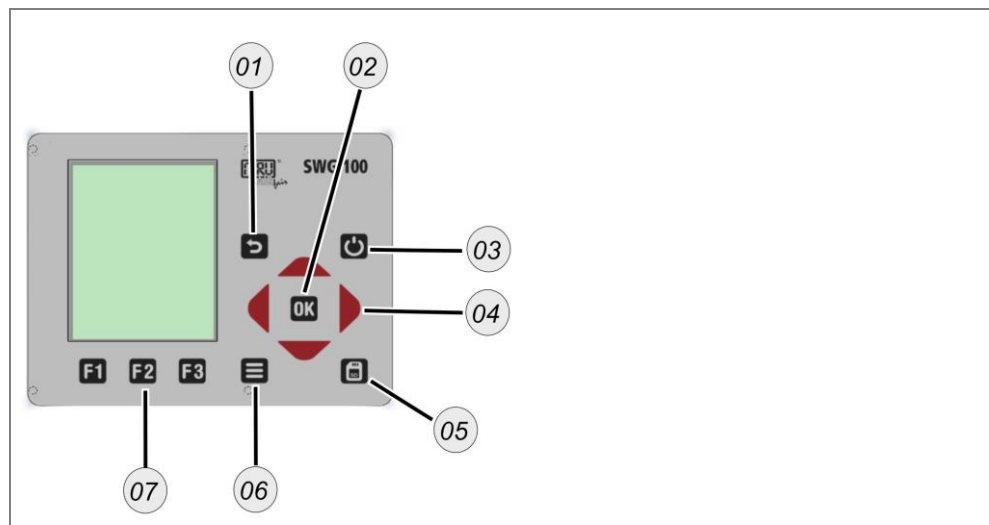

In this chapter you will learn how to operate the unit and make different settings.

It deals in particular with:

- The operation of the unit,
- The measuring menu structure,
- The menu navigation and the setting options.

6.1 Operating and display elements



#	Symbols	Description
1		ESC: abort or return to the menu above
2		OK: confirmation key, select a marked menu point.
3		Prepare Power-Down: Press this key before you disconnect mains. The device will store changed user settings and other operational data and will purge the sensors
4		Arrow keys: context dependent functions, e.g. scroll in between lines, change values, change view.
5		Screen shot: press this key in order to store a screen shot of the current display contents onto the SD card.
6		Menu key: Will show all available functions in the window that is currently in use – also those which have an individual key on the key pad like the printer and the three function keys.
7		Function Keys: Activates the functions seen on the display (2 function key bar)

6.2 Menu structure

After switching on, the unit is in the measuring menu.

- Press the function key **F2** to access the "STORAGE MENU".
- Press the function key **F3** to access the "EXTRAS MENU".

Here you can see the general menu structure.

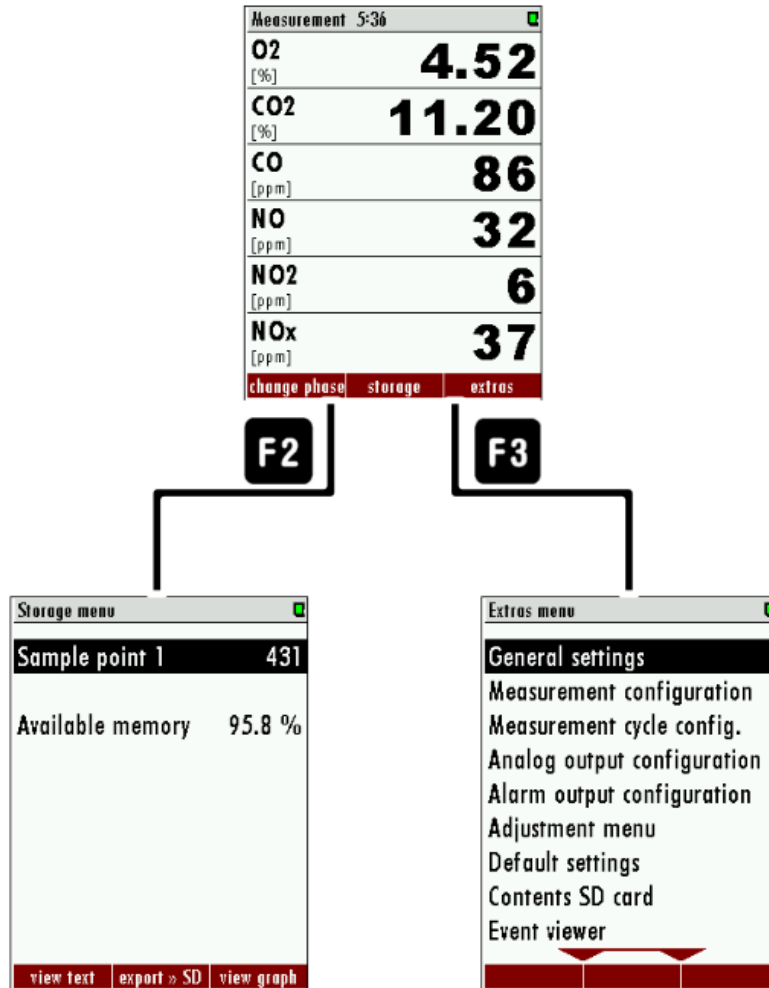

6.2.1 Measuring menu structure

Here you can see the structure of the measuring menu.

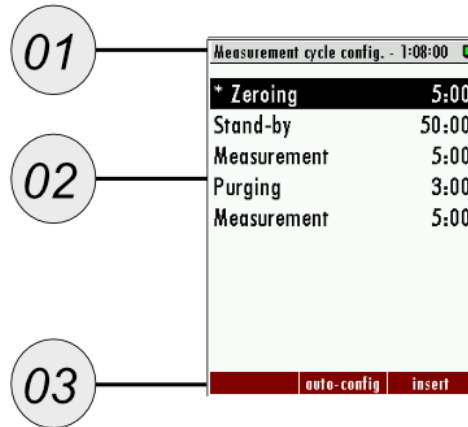

#	Description
1	Menu bar
2	Display field
3	Function bar

6.2.2 Open submenu

Each menu item has a submenu. The submenu may contain additional functions.

STEPS

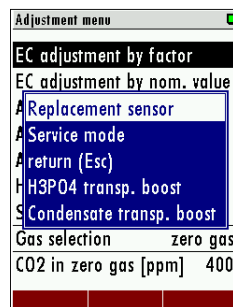

- ▶ Open the menu item you are interested in.

In this example, the menu "ADJUSTMENT MENU". You will find the menu under the path: EXTRAS / ADJUSTMENT MENU.

- ▶ Press the menu key .

A blue window opens with further menu items. The blue window is the submenu.

- ✓ You have called up the submenu.

6.3 Setting options Measuring menu

You can perform the following actions in the measurement window.

- Change the display mode: Zoom / Standard
- Change measurement page.
- Display last measurement point values
- Individual configuration of the measurement window content.

6.3.1 Switch to Zoom/Standard display mode

STEPS

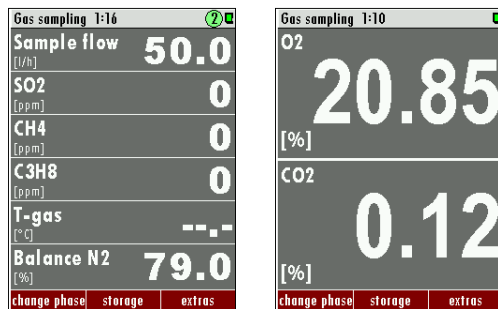

- ▶ Press the **menu button**  in the measurement window.

Submenu opens.

- ▶ Select between zoom view and standard view.

- ✓ The view is selected.

NOTE

For units with only one measuring point, switching is also possible with the *up/down arrow keys* (↑/↓).

6.3.2 Change measurement page

STEPS

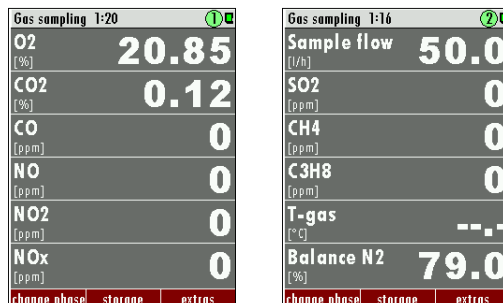

- ▶ Press the **right/left arrow key** (←/→).

- ✓ The page is changed. The page number is displayed in the title bar.

6.3.3 Displaying the last Measuring Point Values

You can display the last values of the measuring points that are not active.

PREREQUISITE

- Your unit has several measuring points.
- i** You do not interrupt the active measurement. However, you can view the last values of the last measuring points. This has no influence on the currently active measurement.

STEPS





- Press the *upper/lower arrow keys* (↔).
- In the menu you will see the values of the next measuring point.

6.3.4 Configuring the Measurement Window

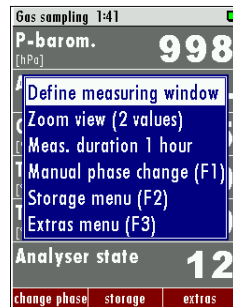
You can change the order of the displayed measurement values in the measurement window.

STEPS



- ▶ Press the **menu key**  in the measurement window.
The **blue submenu** appears.
- ▶ Select "DEFINE MEASUREMENT WINDOW".
The measurement window is active again.
- ▶ Mark the position to be changed with the **up/down arrow keys** ( ).
- ▶ Select the desired display value with the **left/right arrow key** ( .
- ▶ Press the **OK-key** to confirm the display value.
The selected display value appears in the desired position.
- ▶ Confirm the change.
- ✓ The display value in the measurement window is adjusted.
- ✓ Repeat the procedure if desired.

NOTE

With the function "Measurement window autoconfiguration" in the context menu, the measuring device can also make an adjustment independently, which is usually useful.

6.4 Menu: Extras

6.4.1 General settings

General settings	
LCD brightness	60 %
Country	England
Language	English
Keyboard beep	ON
Request admin-PIN	OFF
Service message	OFF
External control	OFF
Thresh.cond.alarm [kΩ]	50
Storage interval	1/m.phase
date & time	modbus

Menu path: EXTRAS / GENERAL SETTINGS.

Setting	Operation	Setting options
LCD Brightness	Arrow keys (←→)	20%...100%
Country	Arrow keys (←→)	Several
Language	Arrow keys (←→)	Several
Key signal	Arrow keys (←→)	ON / OFF
PIN query	Arrow keys (←→)	ON / OFF
Service message	Arrow keys (←→)	ON / OFF
External control	Arrow keys (←→)	Several
Condensate threshold	Arrow keys (←→)	20...100
Gas cooler	Arrow keys (←→)	5...15°C
Date & Time	Function key F1	
Modbus	Function key F3	Several

☞ For Date & Time see chapter: 6.4.9 Set Date & Time.

☞ For Modbus see chapter: 6.4.8 Set the Modbus.

6.4.2 Measurement configuration

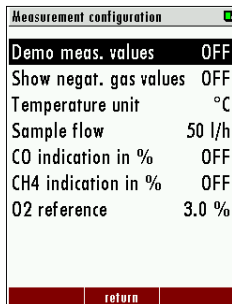

i Menu path: EXTRAS / MEASUREMENT CONFIGURATION.

In this menu you can set the temperature unit used and the volume flow.

Settings	Operation	
Temperature unit	Arrow keys (←→)	°C / F
Sample flow	Arrow keys (←→)	30...70 l/h

6.4.3 Adjustment menu

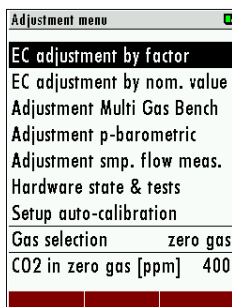

i Menu path: EXTRAS / ADJUSTMENT MENU.

In this chapter you will find all possible adjustment options. You will also find a Hardware Status & Tests menu here.

NOTE

The operation of the individual adjustment menus can be found in the respective measurement technology chapters.

6.4.4 Factory settings

ATTENTION

All saved settings are lost here.

i Menu path: EXTRAS / FACTORY SETTINGS.

This menu item allows you to reset all settings to the factory settings.

6.4.5 Contents SD card



i Menu path: EXTRAS / CONTENTS SD CARD.

This menu item shows you the contents of your SD card.

6.4.6 Event viewer



 Menu path: EXTRAS / EVENT VIEWER.

In this menu, you can view various events, such as times of zeroing or error messages.

6.4.7 Device Info

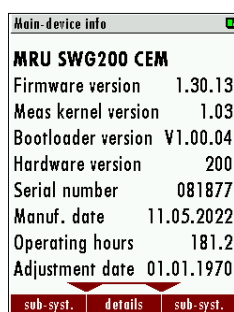

 Menu path: EXTRAS / INFO MAIN DEVICE.

In this menu you get general information about your unit. You can also update the various built-in modules here.

6.4.8 Set the Modbus

STEPS

General settings	Modbus slave settings
LCD brightness 60 %	Port selection 1
Country England	Baud rate 19200
Language English	Slave address 238
Keyboard beep ON	Stop bits 1
Request admin-PIN OFF	Parity even
Service message OFF	Data bits 8
External control OFF	Invalid value -1E38 (MRU)
Thresh.cond.alarm [kΩ] 50	Response delay [ms] 6
Storage interval 1/m.phase	Request count 0
date & time	modbus F3 default Start test user list

▶ Open the menu: Modbus: EXTRAS / GENERAL SETTINGS → **F3**.

The menu window Modbus Slave Settings opens.

▶ Set the required baud rate, slave address and parity / stop bits.

▶ Exit the menu.

▶ Confirm the saving.

✓ The Modbus settings have been made.

6.4.9 Set Date & Time

The unit automatically saves measured values including a time stamp. Therefore, the system clock of the unit should be set correctly.

STEPS

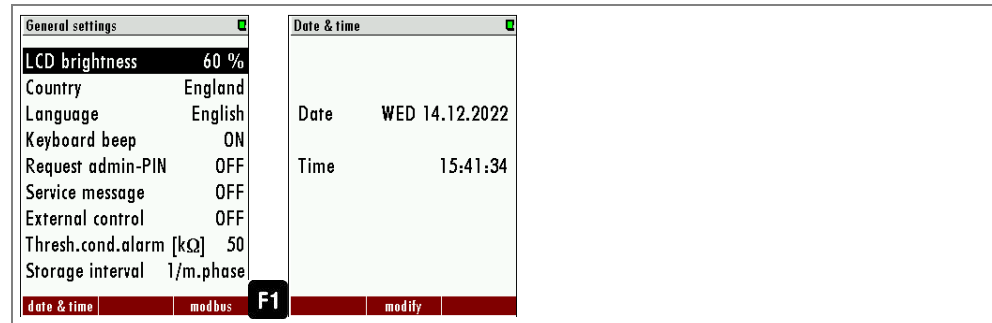

▶ Open the menu: Set date & time: EXTRAS / GENERAL SETTINGS → **F1**.

The menu window SET DATE & TIME opens.

▶ Set the date and time. Press the **F2**-key.

▶ Exit the menu.

▶ Confirm the saving.

✓ The date and time are set.

6.4.10 Menu: Data-store

Data storage	<p>The measured values are stored internally in the unit.</p> <ul style="list-style-type: none">• The unit can store up to 20 000 readings.• The unit stores the current measured values at the end of the measuring cycle for each measuring point.• As soon as the memory space is full, the unit overwrites the oldest measured values (ring memory principle).
Special features	<p>You can equip the unit with an SD card. We recommend that you do this. The unit has a data storage strategy:</p> <ul style="list-style-type: none">• If memory usage is 99%, the oldest 20% of the measurements are automatically saved to an SD card in CSV format and then deleted from the memory in the device.• If the export to the SD card fails (SD card is missing or write-protected), only 4 % of the old measurements are deleted. The file name shows the date of the last measurement exported in the file e.g. "20141031.csv".

NOTE

Example:

A device with 2 measuring points and a configured measuring cycle of 32 minutes stores $2 * 24 * 60/32 = 90$ measurements per day (45 per measuring point). The ring buffer provides capacity for measurements of $20000/90 = 222$ days (more than 7 months).

6.4.11 Calling up the data memory menu

In the memory menu, you can view your saved data:

- View
- Export
- Transfer to other data formats.

STEPS

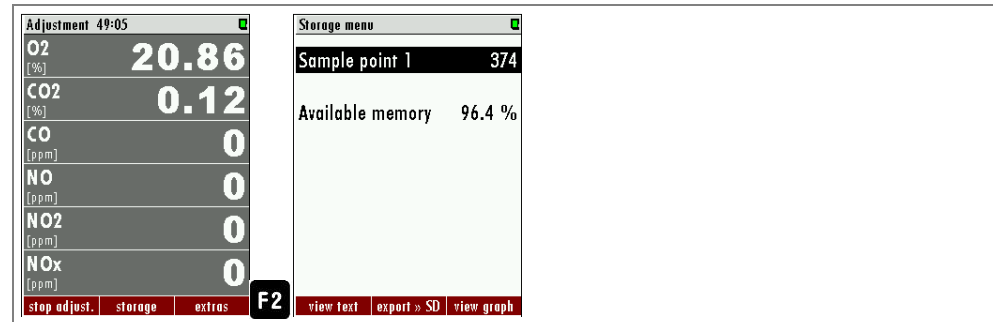

- ▶ Go to the MEASUREMENT WINDOW.
- ▶ Press the **F2**-key in the measurement window.
- ✓ You are in the DATA MEMORY MENU.

6.5 Displaying stored values in text mode

To read stored measurements in text mode, proceed as follows:

STEPS

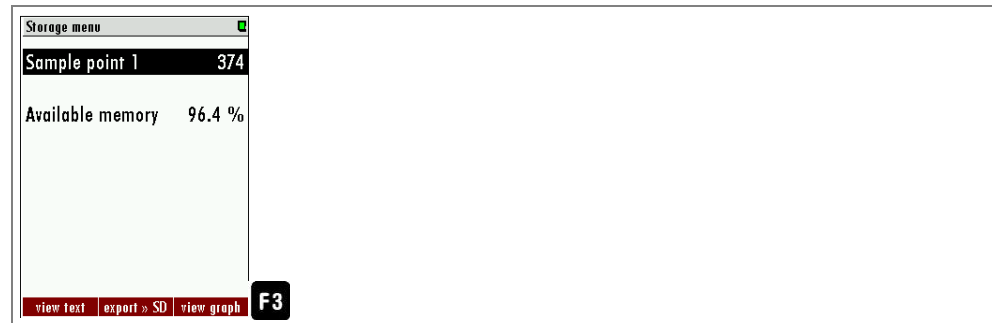

▶ Enter the **DATA MEMORY MENU**.

▶ Press the **F1**-key = „VIEW TEXT“.

The last stored measurement is displayed.

▶ Navigate through the measurements with the *right/left-keys* until you find your measurement.

NOTE

You can use the **F3**-key to go to the last measurement.

You can navigate further with the steps above.

✓ You can continue navigating with the steps above.

6.5.1 Displaying stored values in graphic mode

To read stored measurements in text mode, proceed as follows:

STEPS

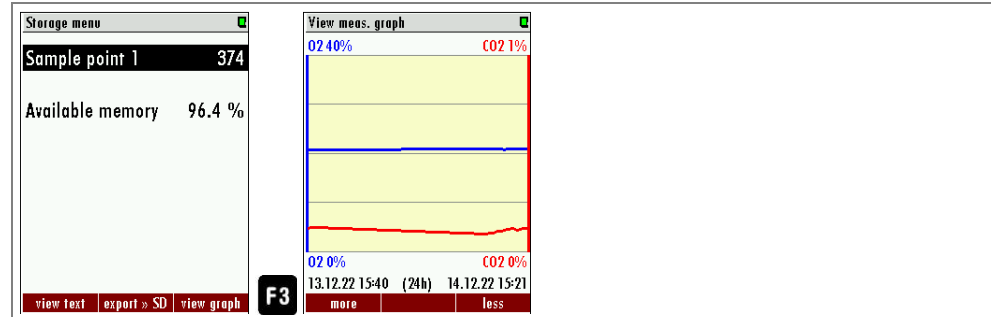

- ▶ Enter the DATA MEMORY MENU.
- ▶ Press the **F3**-key = "VIEW GRAPHIC".

The last stored measurement is displayed.

- ▶ Navigate through the measurements with the *right/left-keys* until you find your measurement.

NOTE

You can use the **F3**-key to go to the last measurement.
You can navigate further with the steps above.

- ✓ You can continue navigating with the steps above.

6.5.2 Export measurement to SD card

You can export your measurements as a CSV file to an SD card.

PREREQUISITE

- ✓ An SD card is in the unit.
- ✓ The SD card must not be write-protected.

NOTE

The CSV format is country-specific. The respective valid CSV format is set via the "General settings" menu.

- ▶ Call up the DATA MEMORY MENU.
- ▶ Press **F2**-key = "EXPORT >> SD".

The CSV files are written to the SD card. When the process is completed successfully, a message appears.

- ✓ The data is saved as CSV format on the SD card.

6.5.3 Setting the CSV format

You can set the CSV format directly on the unit.

Steps

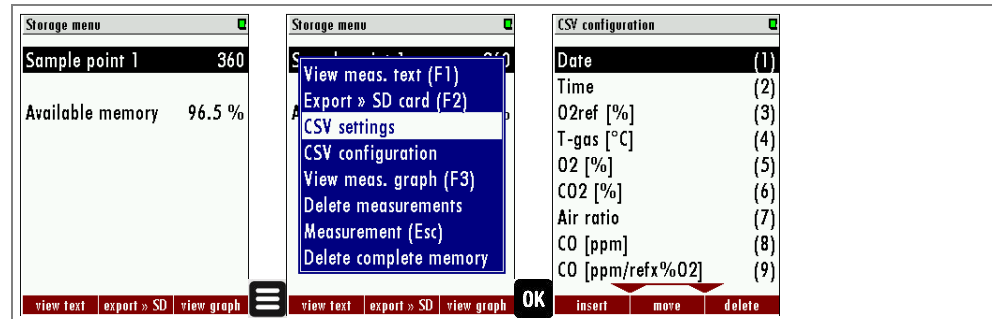

▶ Call up the **DATA MEMORY MENU**.

▶ Press the **menu key** .

The **SUBMENU** opens.

▶ Open the **CSV SETTINGS** menu item.

The **CSV SETTINGS** menu opens (see picture below).

▶ Set your individual settings here.

▶ Exit the menu.

▶ Confirm the saving.

✓ The CSV settings are changed.

See 7 / Setting the measuring cycle Seite 61

7 Setting the measuring cycle

You have the possibility to configure an individual measuring cycle.

There are the phases:

- Zeroing.
- Flush.
- Quiet mode.
- Measurement SP. x (SP.x stands for measurement point 1, 2).

7.1 Menu path and basic structure

Menu path: EXTRAS / CONFIGURATION MEASUREMENT CYCLE.

In this menu you can see the currently active measuring cycle of your unit.

The illustration below and the table show the meaning of the individual sections.

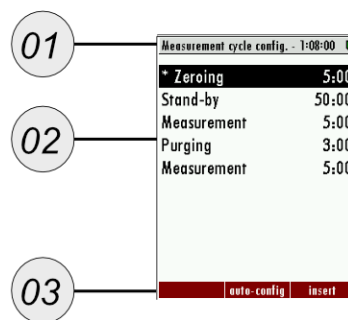

#	Description
1	Duration until end of measuring cycle
2	Measuring cycle list
3	Function keys

7.1.1 Navigating in the menu

You can set each phase individually. To do this, you must call up the phase submenu.

STEPS

- ▶ Select your desired phase with the *up/down arrow key*.
- ▶ Press the **OK**-key.

The phase submenu for the phase appears. In the example below for taking the zero point.

- You can make individual settings here. See the following chapters.

7.1.2 Delete Phase

STEPS

- ▶ Use the up/down arrow keys to select the phase to be deleted.
- ▶ Press the **function key** **F1** to delete the phase.
- ✓ You have deleted the phase.

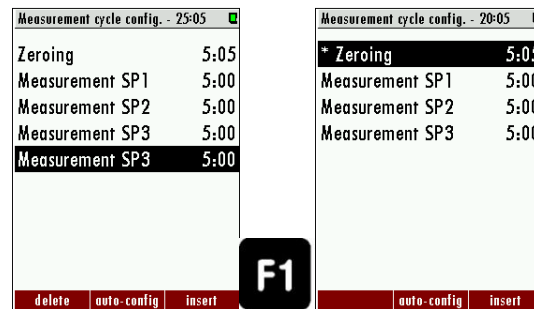

7.1.3 Insert phase

STEPS

- ▶ Press the **function key** **F3**.
- ▶ A new phase appears.
- ▶ Press the **left/right arrow key** to select your desired phase.
- ✓ You have inserted a new phase.

7.1.4 Insert Autoconfiguration

Two standard cycles are stored. You can insert the cycles via **AUTO CONFIG.**

STEPS

NOTE

The autoconfigurations only contain measurements and zero point measurements. Other phases are deleted.

- ▶ Press the **function key** **F2**.
A zero point measurement is inserted at the beginning of the measurement cycle.
- ▶ Press the **function key** **F2** again.
One zero-point reading per measurement is inserted.
- ▶ Select the standard that is reasonable for your measurement application.

Measurement cycle config. - 20:05		Measurement cycle config. - 30:00	
* Zeroing	5:05	Zeroing	5:00
Measurement SP1	5:00	Measurement SP1	5:00
Measurement SP2	5:00	Zeroing	5:00
Measurement SP3	5:00	Measurement SP2	5:00
		Zeroing	5:00
		Measurement SP3	5:00
auto-config insert		auto-config insert	

The two auto configurations in comparison.

7.2 Phase submenus: Setting options

Here you can find out which settings are possible in the phase submenus.

7.2.1 Zeroing (Cycle Phase Details)

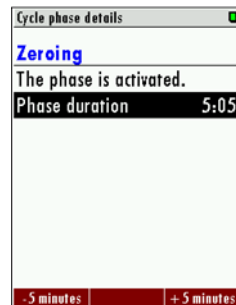

In the menu, the details of the cycle phase for zeroing can be viewed and, if necessary, changed.

Zeroing	
Measuring valve	Closed
Zeroing valve	Open
Duration	2 min to 24 h

7.2.2 Measurement SP.x (Cycle Phase Details)

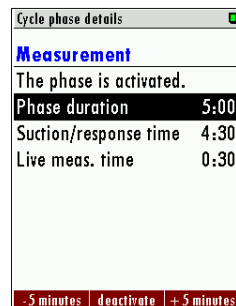

In the cycle phase details, the measuring time and the sampling time can be changed. Each individual measuring point can be adjusted individually.

Measurement SP.x	
Measuring valve	Measuring valve of the current measuring point is open, all others are closed
Zeroing valve	Closed
Duration	2 min to 24 h

7.2.3 Stand by (cycle Phase details)

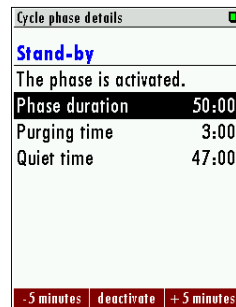

Within this cycle phase, the flushing time and the idle time can be set.

- Duration of the phase: Total idle time.
- Purge time: Purging of the unit with ambient air through the zero gas inlet.
- Sleep time: The time the unit is in sleep mode.

Stand by	
Measuring valve	Closed
Zero valve	Closed
Duration	2 min to 24 h
Flushing time	30 sec. to 1 h
Rest time	calculated

7.2.4 Purging (Cycle Phase Details)

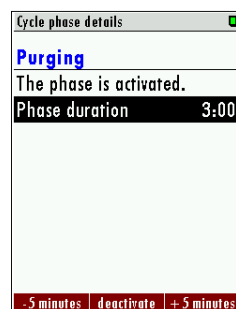

Purging is a separate configuration item for purging the unit with ambient air and thus removing foreign gas from the lines and the measuring equipment. This may be necessary when switching between different measuring points that have different gases or gas concentrations.

Purging	
Measuring valve	Closed
Zero valve	open
Duration	2 min to 24 h

7.3 Example for a measurement cycle configuration

In this chapter, an individual and fictitious measurement cycle is created. The measurement cycle should have the following sequence:

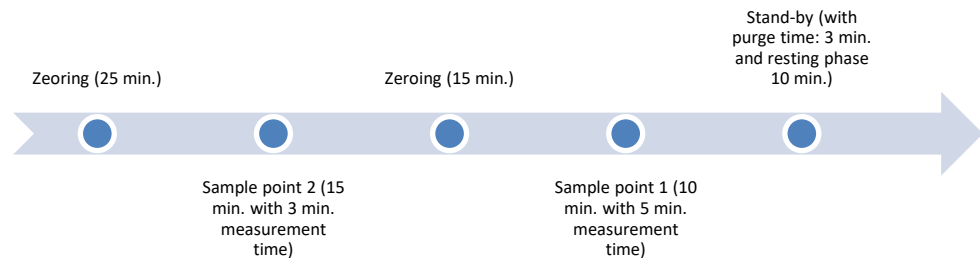

EXAMPLE-STEPS



- ▶ Open the path: EXTRAS / CONFIGURATION MEASURING CYCLE.

The standard measuring cycle appears.

- ▶ Insert a zero-point measurement.

- ▶ Press the **OK** key.

The phase submenu opens.

- ▶ Set the zeroing to 25 min.

The zero point measurement has been set to 25 min.

- ▶ Go back to the configuration measuring cycle menu.

- ▶ Insert the measurement SP.2.

- ▶ Open the phase submenu of measurement SP.2.

- ▶ Change the settings.

- ▶ Proceed in the same way with the items measurement SP.1 and the idle state.

- ✓ The measurement cycle is set.

7.4 Update software

If necessary, the analyser and the various installed options can be updated. The following options are affected:

- The firmware of the analyser.
- The firmware of the main board.
- The firmware of the NDIR cuvette.
- The firmware for the I/O modules.

7.4.1 Overview: Possible system updates

To distinguish the individual firmware updates of the modules, they have typical file names. This always consists of a 4-digit number and an abbreviation of the respective module. The file attachment is always ".fwb".

NOTE

For example, a firmware update could have the following name: xxxxiom.fwb. The number depends on the unit family.

The table below shows the possible firmware names.

Module	Firmware name
Main unit	xxxx.fwb
Main board	xxxxmb.fwb
IO module	xxxxiom.fwb
NDIR cuvette	xxxxndir.fwb

7.4.2 Updating the main unit

STEPS

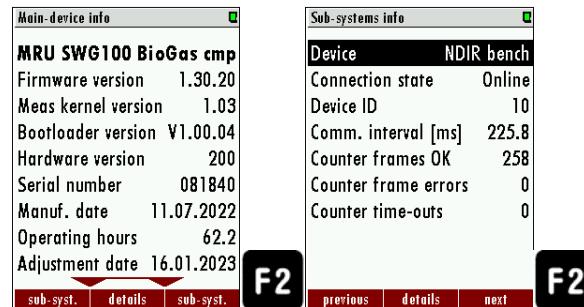

To update the main unit, proceed as follows.

- ▶ Copy the firmware directly to an SD card. Make sure that the firmware is copied in the main menu.
- ▶ Insert the SD card into the SD card reader of the unit. This is located behind the control unit.

The unit emits a sound.
- ▶ Open the menu "EXTRAS / DEVICE INFO".

The menu "Details main unit" appears.
- ▶ Press **F2** = Details.

The unit info window appears.
- ▶ Press **F2** = FW update
- ✓ The update is carried out. The unit restarts.

7.4.3 Updating the different modules

In addition to the main unit, the individual BUS modules can also be updated. Proceed as follows.

STEPS

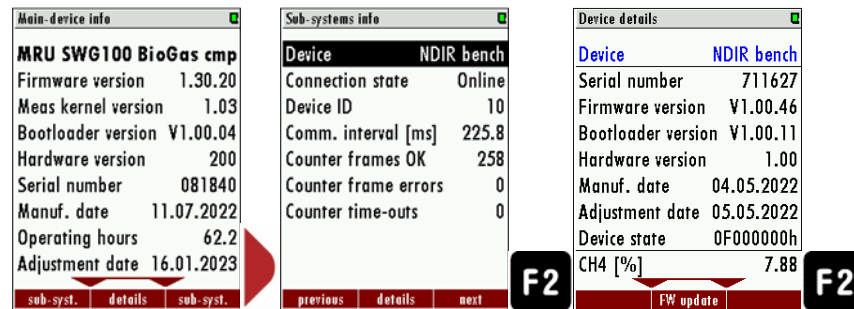

- ▶ Copy the firmware directly to an SD card. Make sure that the firmware is copied in the main menu.
- ▶ Insert the SD card into the SD card reader of the unit. This is located behind the control unit.

The unit emits a sound.

- ▶ Open the menu "EXTRAS / DEVICE INFO".
- ▶ Press the **left/right arrow key**.

The menu "INFO SUB.-SYSTEM" menu appears.

- ▶ Select the menu item "DEVICE".
- ▶ Change to the respective module with the left / right arrow key.
- ▶ Press **F2** = DETAILS.

The menu "Device details" appears.

- ▶ Press **F2** = FW UPDATE.

✓ The update is carried out. The unit restarts in the process.

See also Device description, page 17

See 4 / Device description Seite 17

8 Service and maintenance

⚠ WARNING

Risk of electric shock from the power system voltage

This may result in severe injuries or death.

- Disconnect the device from the power supply before doing maintenance work.
- Check that the system is deenergized.

⚠ CAUTION

Risk due to incorrect maintenance

Malfunctions may occur.

- Scheduled maintenance must be performed by qualified technicians.

⚠ CAUTION

Risk of burn during maintenance work

Burn may result.

- Disconnect the device from the power supply before doing maintenance work.
- Let hot components cool down sufficiently.

The reliable function and measurement quality of the unit can only be guaranteed with regular inspection and maintenance.

In addition to regular routine checks by the operator, the manufacturer recommends regular ½-yearly maintenance (2x per year) of the analyser by a qualified specialist company to maintain reliable function and high measurement quality.

8.1 Preparation and instruction for maintenance

For maintenance work, the main fuse in the unit must be switched off. Even when the main fuse is switched off, dangerous electrical voltages are present on the primary fuse side.

If necessary, disconnect the unit from the electrical supply and secure it against being switched on again.

Dangerous gases may escape during maintenance work on the gas system. The gas supply to the unit must be switched off.

For electrical work as well as for work on the gas system, all nationally applicable directives must be observed at the installation site.

8.2 Regular maintenance work by the operator

All inspection and maintenance work is highly dependent on the individual conditions of use and operation on site. The specified intervals are therefore to be understood as guidelines.

Check	Recommended Interval	Action
Humidity in the device	Weekly	Remove humidity. Remove the cause of the humidity penetration.
Dirt and deposits in the application	Weekly	Remove dirt, prevent further penetration of dirt.
Dirt or humidity on fan filter	Weekly	Replace the fan filter mat.
Visually check gas lines for leaks and seating	Weekly	Replace gas lines if necessary
Inspect condition of gas filters and critical parts (see table)	Monthly	Exchange if necessary

The following lists the parts of the analyser that are critical to the reliable operation of the unit. These parts must be replaced at intervals independent of the regular inspection.

8.3 Maintenance parts: Position overview

8.3.1 The spare parts set #13430

The spare parts set #13430 contains all important spare parts.
You can see them in the table below:

#	Element	Quantity	Article number
1	Filter element PTFE	1	12685
2	Inline filter SOx/NOx	2	56795
3	Inline filter activated carbon	1	65034
4	Filter mats for fan	10	60320
5	PTFE-filter	1	59059
6	Spare parts for peristaltic pumps	2	13405



8.3.2 Spare part position outside

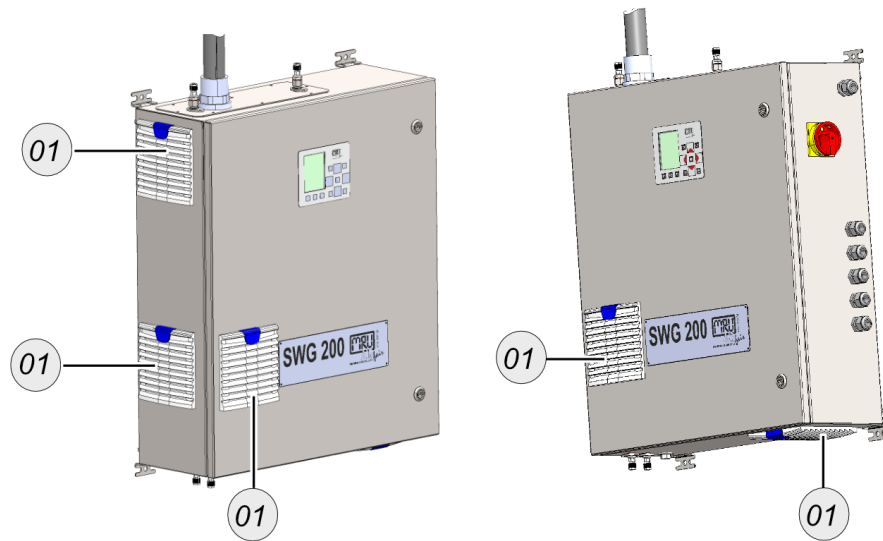

#	Element	Article number
1	Filter mats for fan	60320

8.3.3 Spare part position inside

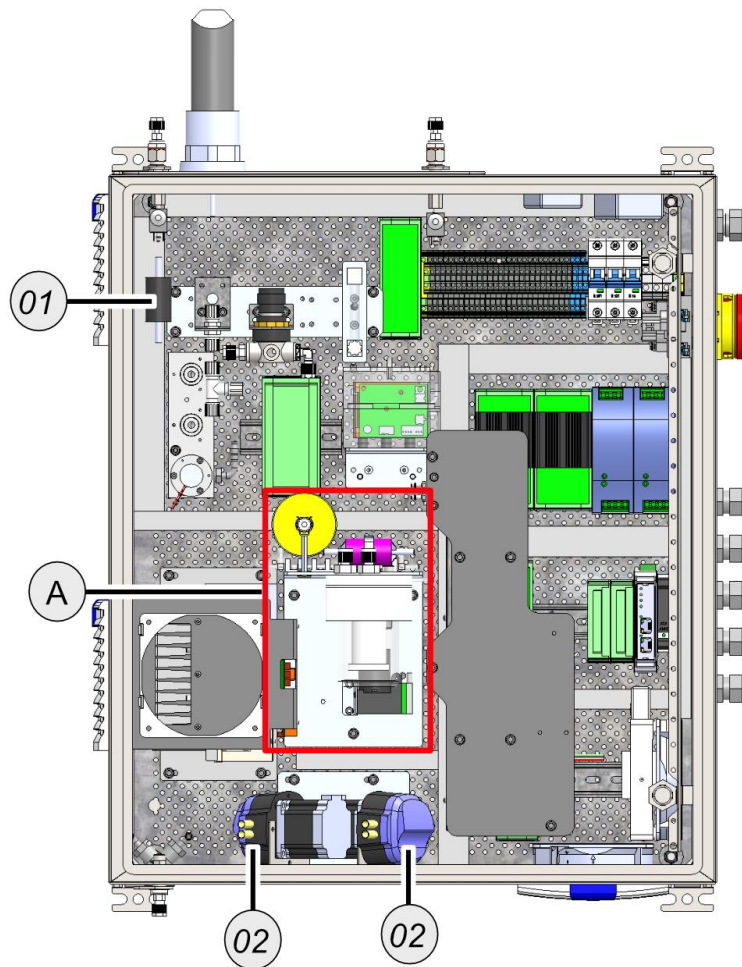

#	Element	Article number
1	Inline filter acitvated carbon	65034
2	Spare parts for peristaltic pumps	13405

Detail A

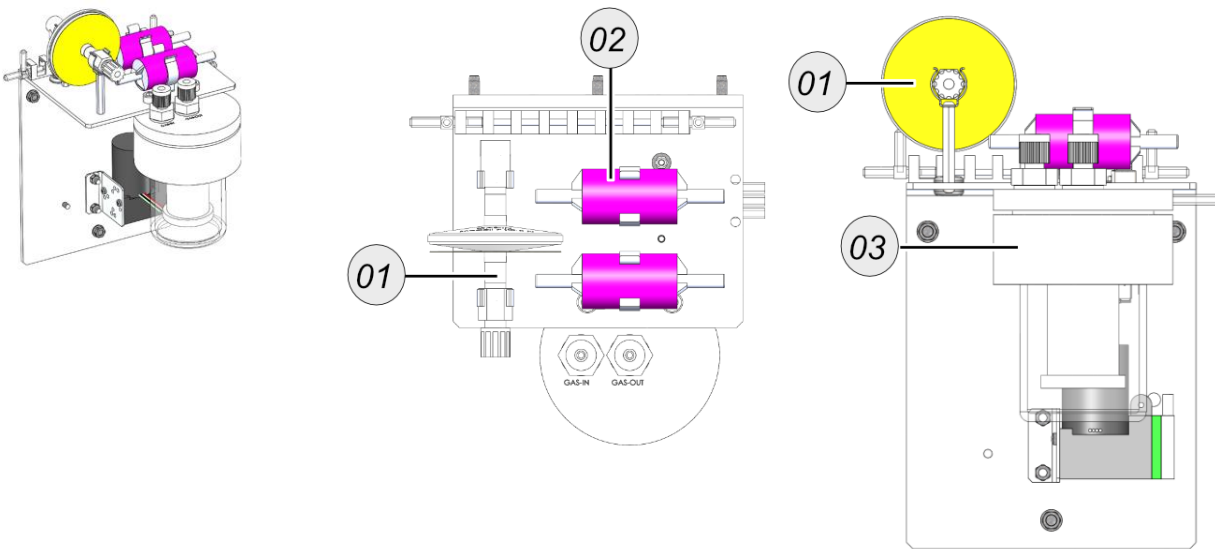

#	Element	Article number
1	PTFE filter	59059
2	Inline filter SOx/NOx	56795
3	Filter element PTFE	12685

8.3.4 Replace filter-mat



PREREQUISITE

- New filtermat

STEPS



- ▶ Push the blue tab **01** of the filter housing.
The filter housing opens.
- ▶ Replace the filter-mat **02**.
- You have replaced the filter-mat.

8.3.5 Replacing the inline filter activated carbon



Inline filter activated carbon

Here you will learn how to replace an **inline filter**.

PREREQUISITES

- The device must be de-energised before replacement.

STEPS

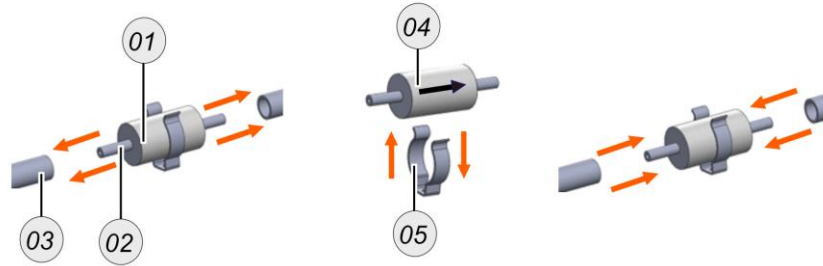

#	Description
1	Filter element
2	Inline filter connector
3	Hose
4	Installation direction
5	Clamp

- Pull the hoses **03** from the **inline filter connections 02**.
- Remove the used **Inline filter** from the clamp **05** if necessary.
The old **Inline filter 01** is removed.
- Attach a new **inline filter** to the clamp **05** if necessary.
- Reconnect the **Inline filter** connections to the hoses.
- You have replaced the **inline filter**.

8.3.6 Replacing the inline Sox / NOx filter



Inline-Filter SOx/NOx

Here you will learn how to replace an **inline filter**.

STEPS

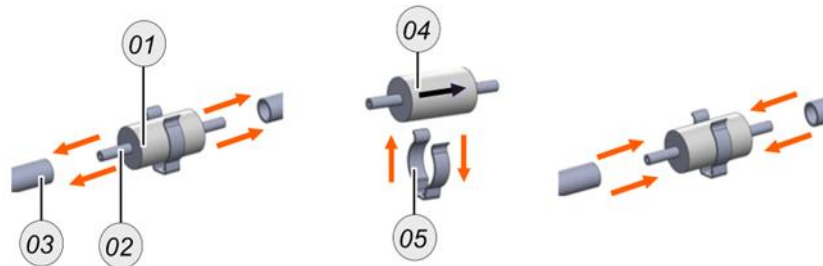

#	Description
1	Filter element
2	Inline filter connection
3	Hose
4	Installation direction
5	Clamp

- ▶ Pull the hoses **03** from the **inline filter connections 02**.
- ▶ Remove the used **Inline filter** from the clamp **05** if necessary.
The old Inline filter is removed.
- ▶ Attach a new **inline filter** to the clamp **05** if necessary.
- ▶ Reconnect the **Inline filter connections** to the hoses.
- ✓ You have replaced the **inline filter**.

8.3.7 Replacing the PTFE filter water stop

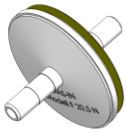

Replacing the PTFE filter water stop

Here you will learn how to replace a **PTFE filter**.

PREREQUISITE

- The unit must be de-energised before replacement.
- You will need an *SW 16 spanner*.
- You need *PTFE sealing tape* or something comparable.

STEPS

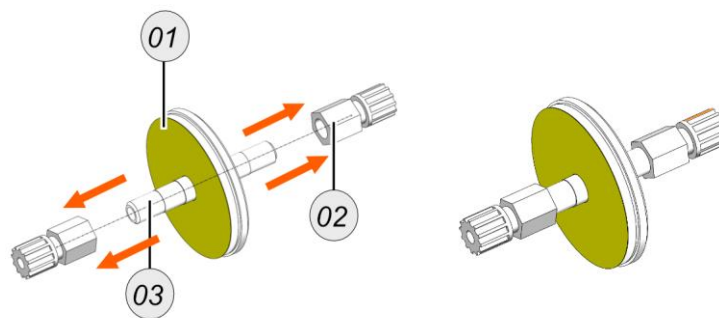

Position	Description
1	PTFE filter
2	Threaded fitting
3	Spigot with outer threaded

- Remove the old **PTFE filter** from the clamps.
- Unscrew the **threaded fittings 02** with an *SW 16 spanner*.
 - The threaded fittings are glued with a sealant.

You have removed the **PTFE filter**.
- Seal the **sockets 03** of the **PTFE filter 01** with *PTFE sealing tape*.
- Screw the **threaded fittings 02** onto the nozzles of the **PTFE filter**.
 - The PTFE filter has an installation direction marked "IN".
- Reattach the **PTFE filter** to the clamps.
- You have replaced the **PTFE filter**.

8.3.8 Replacing the PTFE element of the dust filter

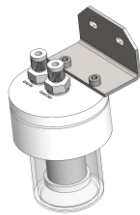

Dust filter with PTFE-element

Here you will learn how to replace the PTFE element from the dust filter.

PREQUISITE:

- New PTFE element.

STEPS:

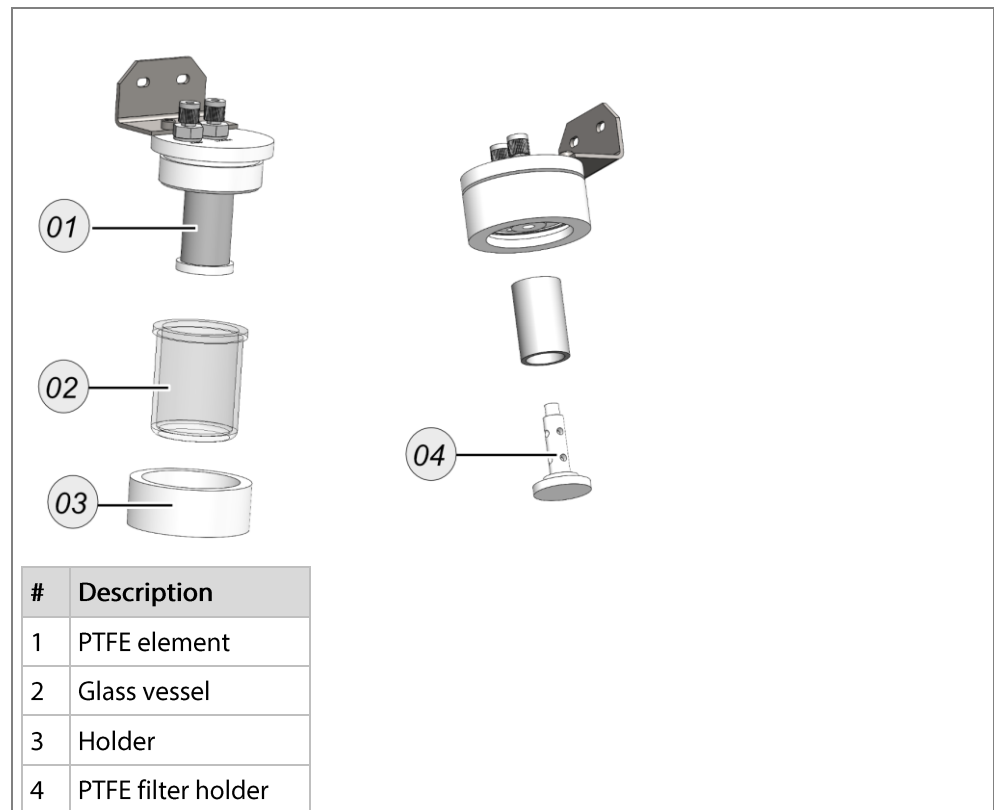

Fig. 1

- Unscrew the retaining ring of the dust filter by hand (Fig1. (3)).
- Remove the glass vessel (Fig.1 (2)).
- Unscrew the PTFE filter holder (Fig.1 (4)).
- Replace the used PTFE element with a new one (Fig.1 (1)).
- Reassemble everything as described.
- You have successfully replaced the PTFE element.

8.3.9 Replacing the condensate pump hose

After a certain period, you must replace the condensate pump hoses.

STEPS

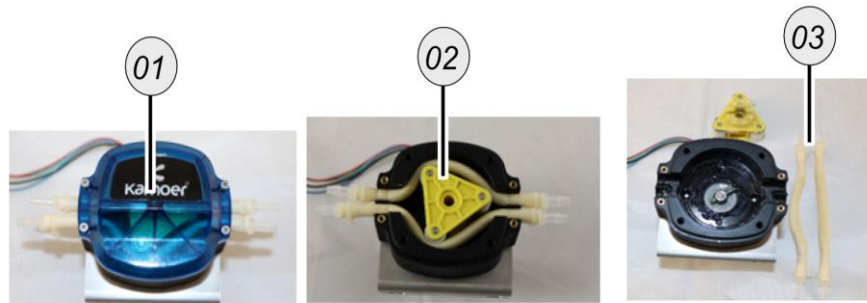

#	Description
1	Peristaltic pump cover
2	Pump head
3	Condensate pump hose

- ▶ Take the hose pump cover **01** with a crosshead screwdriver.
- ▶ Remove the yellow pump head **02**.
- ▶ Replace the condensate pump hoses **03** with new condensate pump hoses.
- ▶ Reinstall the yellow pump head.
- ▶ Screw the peristaltic pump cover back into place.
- ✓ The condensate pump hoses have been replaced.

8.4 Gas adjustment

The adjustment of the individual measuring sensors is described here.

The procedure is always the same, regardless of the measuring sensor:

- Connect the adjustment gas cylinder.
- Open the adjustment menu.
- Adjust the sensor in the right menu.

8.4.1 Connect adjustment gas cylinder

⚠ WARNING

High pressure

Adjustment gas cylinder stands under high pressure. May cause injuries and death.

- Choose the correct gas.
- Select the right gas selection.

In this chapter you will see, how to connect the gas adjustment cylinder with the device.

STEPS: SET GAS SELECTION IN THE MENU

- ▶ Open the menu: EXTRAS / ADJUSTMENT MENU.
- ▶ Choose the menu point GAS SELECTION.

⚠ WARNING – Incorrect gas connection. This can lead to injuries and damage to property. As standard, an adjustment bottle dire may only be connected via the Calibration gas inlet.

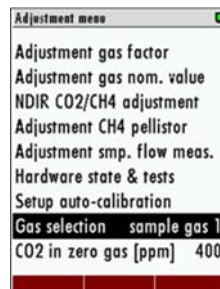

✓	Gas selection	calibr.gas
✗	Gas selection	sample gas 1
✗	Gas selection	zero gas

- ▶ Use the left / right arrow key to set the gas selection to Calibr. gas. Gas.
- ✓ The unit now draws the gas from the calibration gas inlet in calibration mode.

STEPS: CONNECT ADJUSTMENT GAS CYLINDER ON CALIBRATION GAS INLET

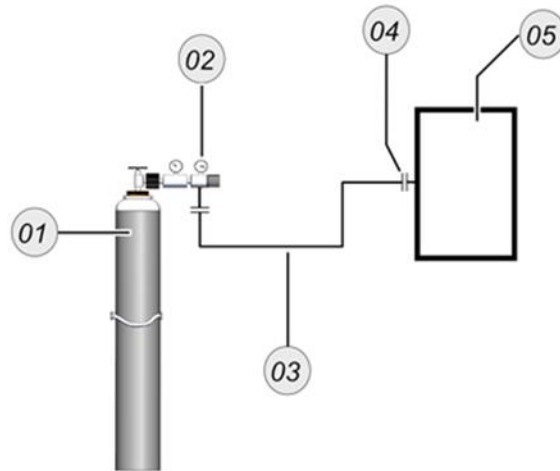

#	Description
1	Adjustment gas cylinder
2	Pressure reducer (max. 500 hPa)
3	DN4/6 mm PTFE-hose
4	Calibration gas inlet
5	Device



Gas reducing unit must be installed

⚠ WARNING – Mount the Gas reducing unit DN4/6 on position 4 (see picture in the margin.)

- Screw the **Gas reducing unit** on the **Calibration gas Inlet**, if not already done.
- Connect the **adjustment gas cylinder** directly to the **gas reducing unit** mounted on the **Calibration gas Inlet** using a **PTFE-DN4/6 mm hose**.

✓ The adjustment gas cylinder is mounted correctly.

8.4.2 Adjust Multi Gas Bench

Here you learn how to calibrate a NDIR-bench.

PREREQUISITE

- Diverse adjustment gas cylinders. Depend on the installed measurement technique.
- Normally the gas concentration of the adjustment gas cylinder should be between 70% of the full-scale of the measurement range.
- Adjustment set-up must be set up.

ATTENTION

The adjustment gas cylinder must remain closed until you are instructed to open the adjustment gas cylinder.

STEPS



- Open the menu: Adjustment: EXTRAS / ADJUSTMENT MENU.
- Open the X-X menu.

Abgleich Multi Gas Küvette	
CH4 [ppm]	0.4
Unt. Sollwert	450 1.000
Ob. Sollwert	4500 1.000
CO2 [%]	0.056
Unt. Sollwert	5.000 1.000
Ob. Sollwert	15.000 1.000
CO [ppm]	0.2
Unt. Sollwert	135 1.000
Ob. Sollwert	2250 1.000
Nullpunkt	Standard
4	5

Fig.1

NOTE

The adjustment menu opens. The adjustment menu has the following structure.

#	Description
1	Gas designation with actual value
2	Lower setpoint with current setpoint concentration and factor
3	Upper setpoint with current setpoint concentration and factor
4	Zero point (F1-key)
5	Reset adjustment to standard (F3-key).

- ▶ Use the **up / down arrow keys** to select the lower setpoint of the gas to be balanced (Fig1 (2)).
 - i Choose the lower setpoint for an one-point adjustment.
- ▶ Press the **right / left arrow key**.

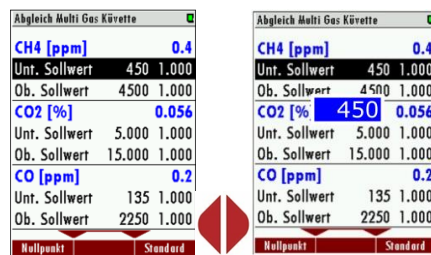

A blue window appears. The current setpoint is entered in the blue window.

- ▶ Use the **arrow keys** to enter the setpoint of your adjustment gas cylinder.
- ▶ Press the **OK-key** to confirm.
- ▶ Now open the adjustment gas cylinder.

The actual value in the adjustment window changes.

- ▶ Wait until the actual value no longer changes.

i You can only change the actual value when the target concentration has reached a certain minimum value. Inverted commas show you if this range has been reached.

- ▶ Press the **OK key** to adjust the actual value to the setpoint.

Follow window appears.



- ✓ The adjustment is finished.

Unt. Sollwert '60' 1.000
Ob. Sollwert 100 1.000

Inverted commas show whether you can change the actual value



8.4.3 Adjust the electrochemical O2-sensor

8.4.4 Adjust electrochemical O2 sensor



O2-sensor

Here you will learn how to replace and calibrate an electrochemical oxygen sensor.

PREREQUISITE:

- O2 sensor (spare part)
- 10 vol. % O2 adjustment gas cylinder rest 90 Vol. %.
- Adjustment set-up must be set up

STEPS: INSTALL SENSOR



01

Fig. 1

- Unplug the O2 sensor to be replaced from the circuit board (Fig.1 (1)).

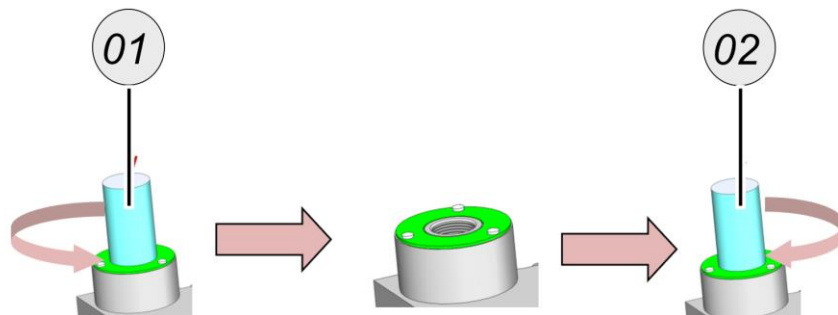

Fig. 2

- Rotate the O2 sensor to be submerged out of the sensor chamber (Fig.2 (1)).
- Turn the new O2 sensor into the sensor chamber (Fig.2 (2)).

▶ Insert the new O2 sensor into the circuit board.

✓ The O2 sensor is installed.

STEPS: ADJUSTMENT

▶ Open the adjustment menu: EXTRAS / ADJUSTMENT MENU .

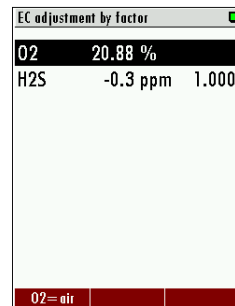

Fig. 1

▶ Open the menu-point → EC ADJUSTMENT BY FACTOR.

The EC adjustment menu appears.

▶ Press F1: O2 = air.

The O2-sensor is adjusted by ambient air, with a O2-concentration of 20,96 vol.%.

▶ Connect the adjustment gas cylinder on the Calibration gas Inlet.

▶ Open the adjustment gas cylinder.

The O2-concentration decrease.

▶ Wait until the actual O2 value no longer changes.

When the O2 concentration is close to 10 vol.%, the message "Auto Span" appears in the lower function bar.

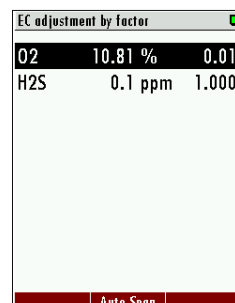

Fig.2

▶ Press F2: Auto Span.

The O2 value is adjusted to 10 vol.%.

▶ Confirm save.



- ▶ Exit the menu.
- ✓ The O2 sensor is calibrated.

8.4.5 Adjustment electrochemical sensors



⚠ WARNING

Connect the adjustment gas-cylinder correctly

Adjustment gas-cylinder are under high pressure and may contain toxic gases. Can lead to death.

- Only trained personnel may connect adjustment gas-cylinder:

Here you will learn how to replace and adjust an electrochemical sensor. There are generally the following sensor designs:

#	Model	Removal instruction
1	A	👉 See section:
2	B	👉 See section:
3	C	👉 See section:



PREREQUISITE:

- Respective sensor
- Adjustment gas-cylinder with 70 % of the upper measuring range
- Adjustment setup must be set up

STEPS: INSTALLING SENSORS MODEL A

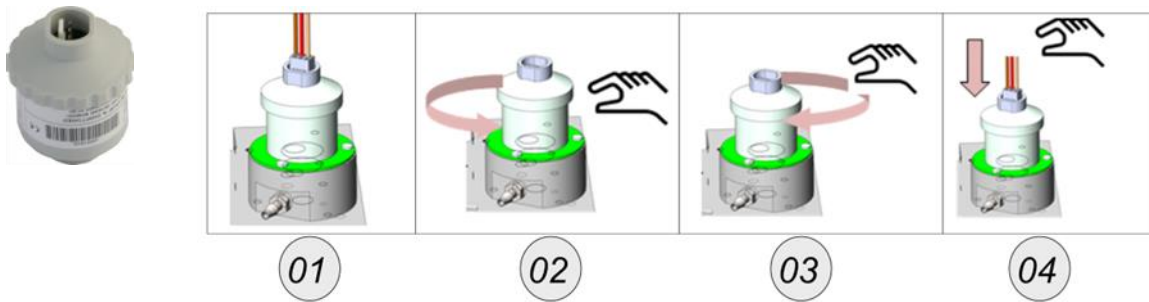

- ▶ Remove the plug from the sensor (1).
- ▶ Turn the sensor to be immersed out of the sensor chamber (2).
- ▶ Turn the new sensor into the sensor chamber (3).
- ▶ Put the plug back on the sensor (4).

✓ You have replaced the sensor.

STEPS: INSTALLING THE SENSORS MODEL B

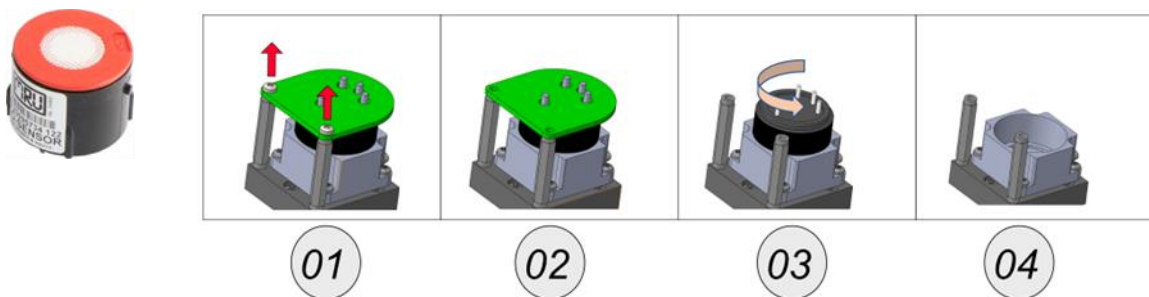

- ▶ Loosen the screws from the sensor board (1).
- ▶ Remove the sensor board from the sensor (2).
- ▶ Turn the sensor out of the sensor chamber (3).

The sensor chamber can be fitted with a new sensor.

- ▶ Install the new sensor.

✓ You have replaced the sensor.

STEPS: INSTALLING THE SENSORS MODEL C

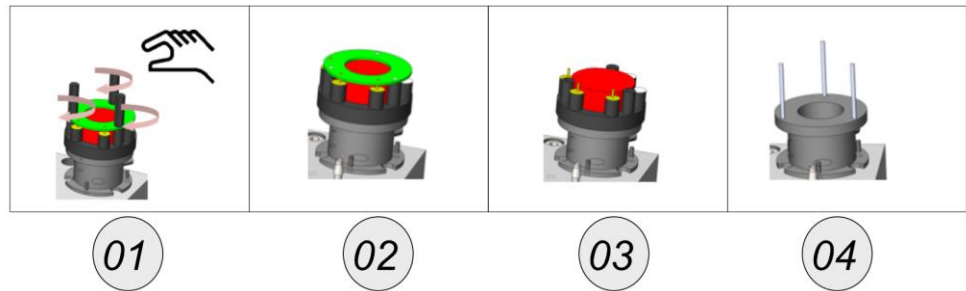

- Rotate the plastic holders from the circuit board (1).
- Remove the sensor board from the sensor (2).
- Remove the sensor from the sensor chamber (3).

The sensor chamber can be fitted with a new sensor.

- Install the new sensor.
- ✓ You have replaced the sensor.

STEPS: ADJUSTMENT

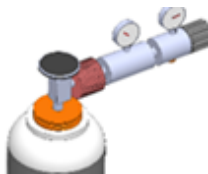

Abgleichflasche jetzt öffnen

- Open the settings menu: EXTRAS / SETTINGS MENU.
- Open the ECS ADJUSTMENT menu item.

The ECS setting menu appears.

▲ WARNING - High pressure. Connect the gas gas-cylinder correctly as described in the instructions.

- Connect the respective adjustment gas-cylinder to the adjustment fitting.

Now open the adjustment gas-cylinder

- Open the adjustment gas-cylinder.

The actual value changes in the adjustment window.

- Wait until the gas value no longer changes.
- Change the factor with the arrow key left/right until the setpoint of the gas gas-cylinder is reached.

The sensor is adjusted to the setpoint.

- Exit the menu.
- Confirm saving.
- ✓ The sensor is adjusted.

8.4.6 Adjust paramagnetic O2-sensor

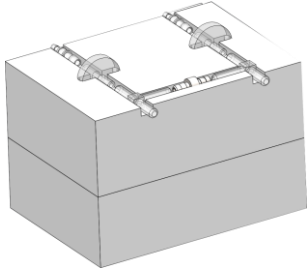

O2-sensor

Here you will learn how to replace and calibrate an electrochemical oxygen sensor.

PREREQUISITE:

- O2 sensor (spare part)
- 100 vol. % N2 adjustment gas cylinder
- Adjustment set-up must be set up

STEPS: ADJUSTMENT

- Open the adjustment menu: EXTRAS / ADJUSTMENT MENU .

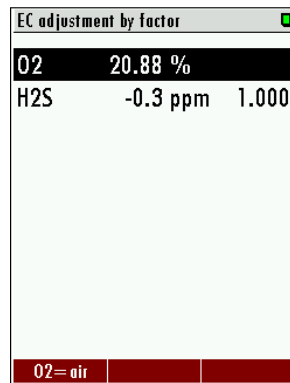

Fig. 1

- Open the EC ADJUSTMENT BY NOM. VALUE menu item (Fig.1).

The adjustment menu appears.

- Connect the 100 vol.% N2 gas cylinder to the adjustment setup.
- Open the N2 gas cylinder.

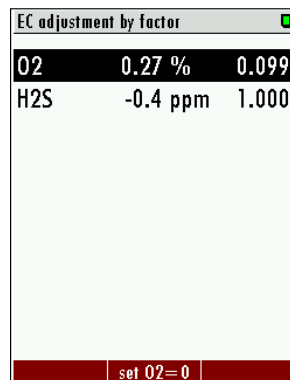

Fig. 2

The O2 value drops (Fig.2).

- ▶ Wait until the O2 value no longer changes.



EC adjustment by factor		
O2	0.27 %	0.099
H2S	-0.4 ppm	1.000

EC adjustment by nom. value		
O2	0.00 %	10.0
H2S	-0.3 ppm	500.0
Zero offset [mV]	0.221	

Fig. 3

- ▶ Press F2. (Fig.3).

The O2 sensor is calibrated at the value O2=0 vol.%.

In the next step, apply ambient air to the sensor. This calibrates the sensor to the atmospheric oxygen O2 = 20.97 vol.%.

- ▶ Remove the N2 adjustment gas cylinder.
- ▶ Wait until the O2 value no longer changes.
- ▶ Press F2.

The O2 sensor is calibrated to 20,97 vol.% O2.

- ▶ Exit the menu.
- ▶ Confirm save.
- ✓ The O2 sensor is calibrated.

9 Option

9.1 Option: IO module

IO modules are the interface for signal transmissions, remote control and for reading signals from transmitters.

IO modules have the following features:

- Transmission of measurement signals, through four separate 4-20 mA outputs,
- Two alarm outputs,
- One PT-1000 input,
- One thermocouple input (type: K),
- Four inputs, for standard 4-20 mA transmitters (2-wire, 3-wire, 4-wire) with an extra power supply.
- Two inputs, for voltage transducers.
- Remote control function for the analyser.

9.1.1 IO module position

Optionally, an device can be equipped with IO modules (max.: 10 pieces).
The IO modules are located on the top-hat rail.

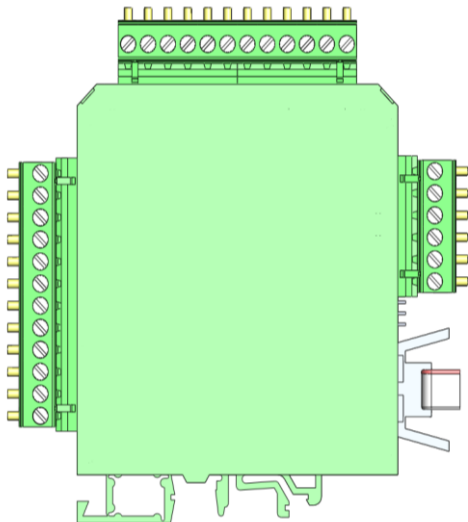

9.1.2 Pin assignment

The following pin assignment diagram shows where the different pins, with their respective functions, can be found and which pins have a double assignment.

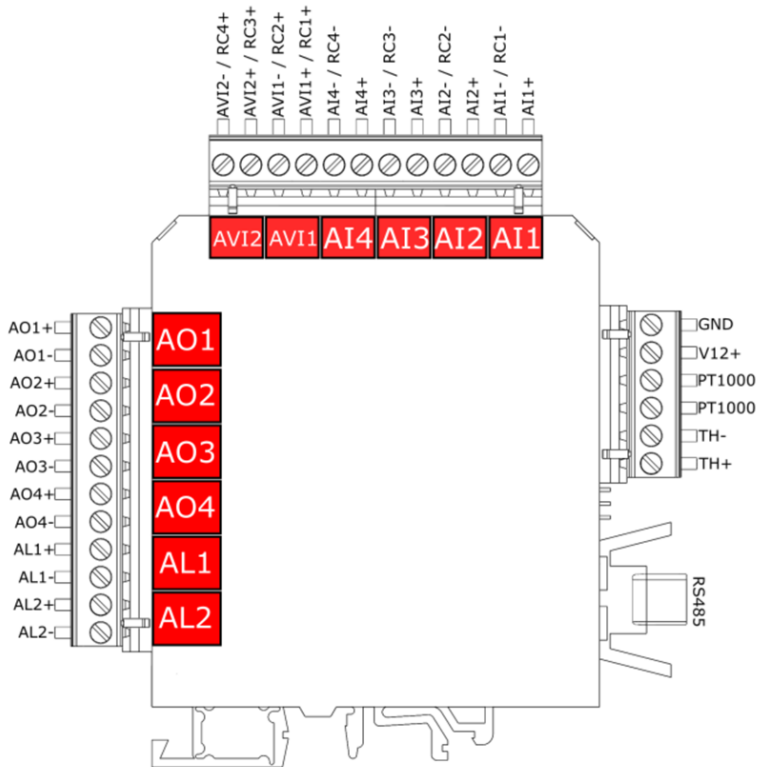

Pin assignment of IO modul

The table shows the assignment of the respective individual pins.

Description	Abkürzung	PINs	Max. externe Spannung	Bürde	Messwiderstand	Doppeltbelegung
Analoge-Ausgänge 4-20 mA	AO1	AO1+ / AO1-	--	500R	--	Nein
	AO2	AO2+ / AO2-	--	500R	--	Nein
	AO3	AO3+ / AO3-	--	500R	--	Nein
	AO4	AO4+ / AO4-	--	500R	--	Nein
Alarmausgänge	AL1	AL1+ / AL1-	24 VDC	500R	--	Nein
	AL2	AL2+ / AL2-	24 VDC	500R	--	Nein
Analoge Eingänge 4-20 mA	PWROUT	V12+ / GND	--	--	--	Nein
	AI1	AI1+ / AI1-	--	--	50R	AI1- = RC1-
	AI2	AI2+ / AI2-	--	--	50R	AI2- = RC2-
	AI3	AI3+ / AI3-	--	--	50R	AI3- = RC3-
	AI4	AI4+ / AI4-	--	--	50R	AI4- = RC4-
Fernbedienung	RC1	RC1+ / RC1-	--	--	--	RC1- = AI1-
	RC2	RC2+ / RC2-	--	--	--	RC2- = AI2-
	RC3	RC3+ / RC3-	--	--	--	RC3- = AI3-
	RC4	RC4+ / RC4-	--	--	--	RC4- = AI4-
Analoge Eingänge 0-10 V	AVI1	AVI1+ / AVI1-	--	--	--	JMP1_out = AVI1+ JMP2_out = AVI1-
	AVI2	AVI2+ / AVI2-	--	--	--	JMP3_out = AVI2+ JMP4_out = AVI2-

9.1.3 Analogue outputs 4-20 mA (AO1-AO4)

Installation/Connection

🔗 Assignment: See 1.1.2 Pin assignment

Setting up analogue output

You can set up to 4 analogue outputs per IO module.

Precondition: The IO module option is installed.

- ▶ Open the path "EXTRAS / CONFIGURAT. ANALOGUE OUTPUTS" path.
- ▶ Select the respective IO output and confirm with "DETAILS".

The setting window of the IO output appears.



Selection window: MS1 = measuring point 1 , I/O 1/1 = first IO module at the first 4-20 mA output.

- ▶ Select the measuring point and the measured variable.
- ▶ Apply the minimum (4 mA) and maximum (20 mA) for the measured variable.

The analogue output is now configured.

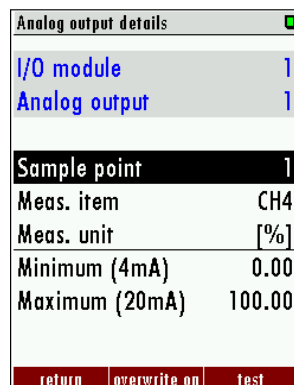

Setting the measuring point, the measured variable and the range for a 4-20 mA output.

9.1.4 Alarm Output Setting (AL1-AL2)

Installation/Connection

📄 Assignment: See 9.1.2 Pin assignment.

Setting the alarm output

You can set up 2 alarm outputs per IO module.

Precondition: The IO module option is installed.

- ▶ Open the path "EXTRAS / CONFIGURAT. Open the path "EXTRAS / CONFIGURE ALARM OUTPUTS".
- ▶ Select the respective alarm output and confirm with "Details".

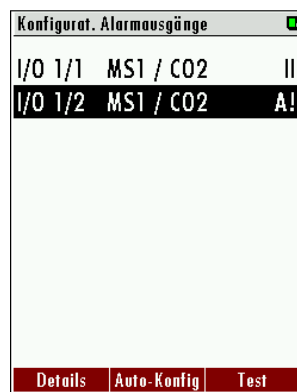

Selection window: MS1 = measuring point 1, I/O 1/1 = first IO module at the first alarm output.

The setting window of the alarm output appears

- ▶ Select the measuring point and the measured variable here.
- ▶ Enter the limit value.

Under "Alarm if value..." you can set whether the alarm is triggered below the limit value or when the limit value is exceeded.

- ▶ Under "If value invalid" you can set whether an alarm is triggered or the unit switches off.

The alarm output is now configured.

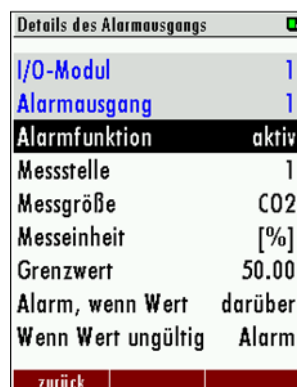

Setting the measuring point, the measured variable, the limit value and the alarm side (exceeding or falling below).

9.1.5 AUX input for transmitter (AI1-AI4)

📄 Assignment: See 9.1.2 Pin assignment

The following 4-20 mA transmitters can be read in at the AUX inputs:

- 2-wire
- 3-wire
- 4-wire.

The IO module has a separate 12V power supply for the connected transmitters.

AUX input: Technical data

- Measuring resistor: 50 Ohm
- Power supply: 12 VDC / 200 mA

Connection: 2-wire transmitter

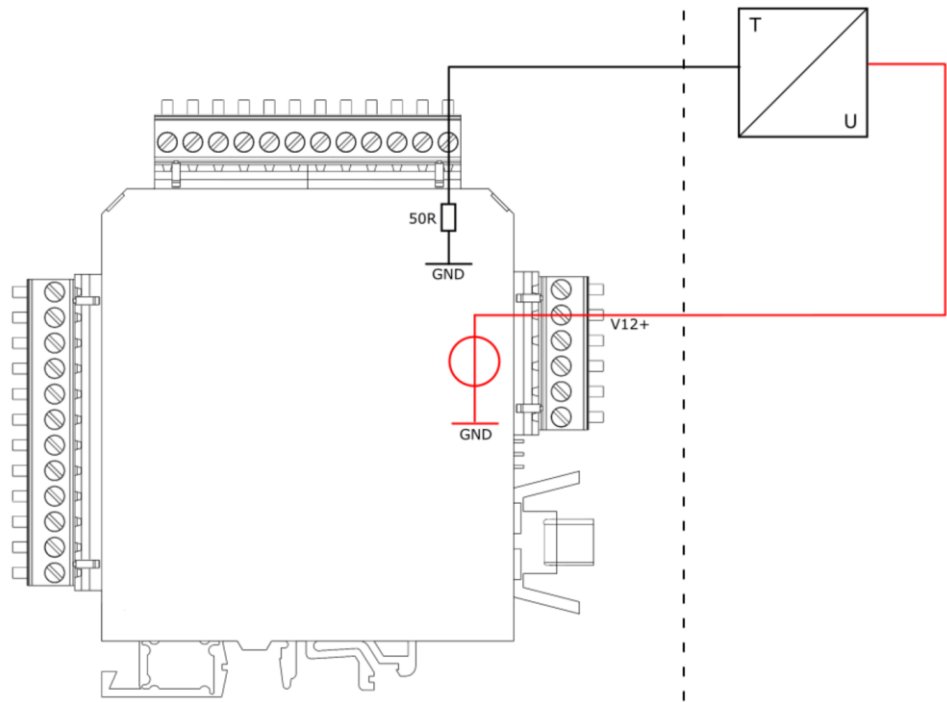

2-wire transmitter, connected to the 12 VDC of the IO module.

Connection: 4-wire transmitter

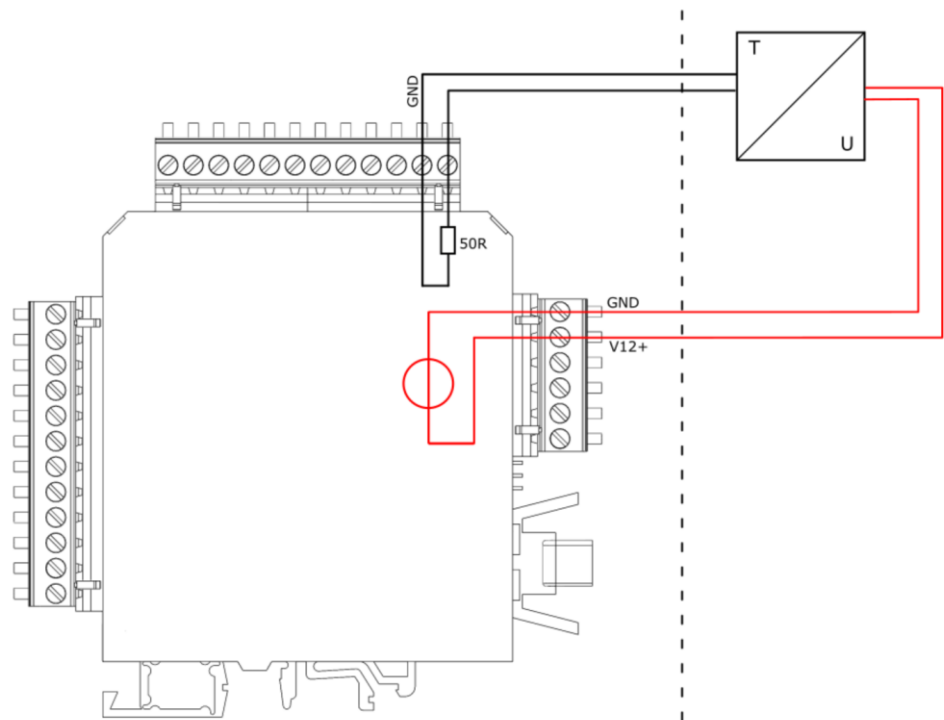

4-wire transmitter, connected to the 12 VDC supply of the IO module.

9.1.6 Set up AUX input

You can assign 4 AUX inputs per IO module.

Precondition: An IO module is installed.

- ▶ Open the path "EXTRAS / CONFIGURATION AUX INPUTS".
- ▶ Select and activate the respective AUX input.

Details des AUX-Eingangs		Konfiguration AUX-Eingänge	
I/O-Modul	1	I/O 1/1	AUS
AUX-Eingang	1	I/O 1/2	AUS
		I/O 1/3	AUS
Messgröße	AUS	I/O 1/4	AUS

Selection window example: I/O 1/1 = first IO module at the first AUX input.

The setting window of the AUX input appears.

- ▶ In this window, the measured variable can be selected. In addition, an individual AUX input can be created under "ADJUSTABLE".
- ▶ Create the minimum (4 mA) and maximum (20 mA) for the measured variable.

9.1.7 Configuration External Control (Option: I/O Module)

To use this function, an I/O module must be present and the function must be enabled.

With this function it is possible to control the analyser remotely. The following operations can be carried out with the help of the external control:

- Sampling.
- Triggering a stand-by mode.

The commands are given by a 4-digit binary code, which is transmitted by four external signals. There are a total of three different transmission paths:

- Through four potential-free relays.
- Through four 4...20 mA inputs.
- Through one 4...20 mA input.
- Through the RS 485 interface.

Setting up external control

An external control can be set up on an IO module via the upper analogue outputs.

- ▶ Open the path "EXTRAS / GENERAL SETTINGS".
- ▶ Select "EXTERNAL CONTROL" here.
- ▶ Use the *left/right arrow keys* to select the desired external control.

By selecting the external control, the unit can be controlled remotely.

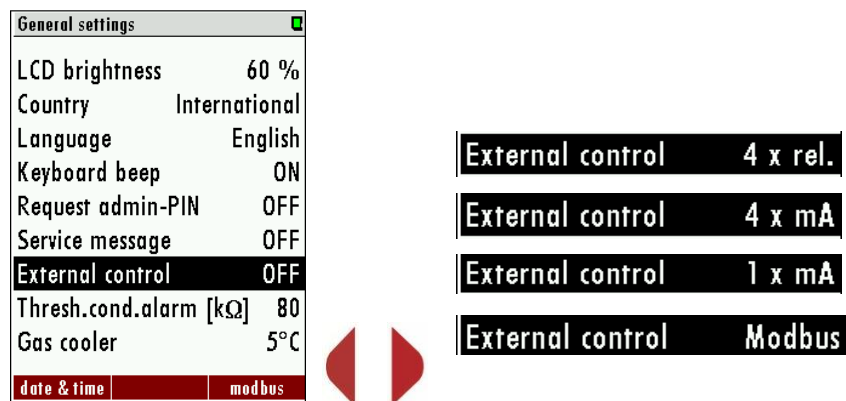

General settings	
LCD brightness	60 %
Country	International
Language	English
Keyboard beep	ON
Request admin-PIN	OFF
Service message	OFF
External control	OFF
Thresh.cond.alarm [kΩ]	80
Gas cooler	5°C

External control	4 x rel.
External control	4 x mA
External control	1 x mA
External control	Modbus

Activating the external control with the respective 4 possible options.

By activating the external control, a small arrow appears in the upper bar.

- ▶ You can set the zero point time, the suction / reaction time or the rinsing time before stand-by in the menu "General settings" with F2 (=ext Ctrl.).

After everything has been set, the external remote control must be wired.

Connecting the external control through 4 relays

This function can be used for external switching between the tapping points. For this purpose, four external relays (e.g. from a PLC) are connected to the module inputs.

The four relays together form a binary 4-bit code: RC4-RC3-RC2-RC1.

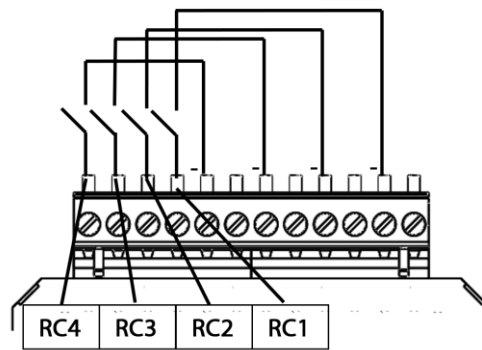

Status of external signal source				Status number	Description
RC4	RC3	RC2	RC1		
0	0	0	0	0	Automatic sampling point switching
0	0	0	1	1	Analyzer is sampling the point SP1 (*1, *2)
0	0	1	0	2	Analyzer is sampling the point SP2 (*1, *2)
0	0	1	1	3	Analyzer is sampling the point SP3 (*1, *2)
0	1	0	0	4	Analyzer is sampling the point SP4 (*1, *2)
0	1	0	1	5	Analyzer is sampling the point SP5 (*1, *2)
0	1	1	0	6	Analyzer is sampling the point SP6 (*1, *2)
0	1	1	1	7	Analyzer is sampling the point SP7 (*1, *2)
1	0	0	0	8	Analyzer is sampling the point SP8 (*1, *2)
1	0	0	1	9	Analyzer is sampling the point SP9 (*1, *2)
1	0	1	0	10	Analyzer is sampling the point SP10 (*1, *2)
1	0	1	1	11	Analyzer is "stand-by" (*3)
1	1	0	0	12	Purge phase for H2S-low-sensor **
1	1	0	1	13	Auto-Calibration
1	1	1	0	14	Remote reset of all system alarms
1	1	1	1	15	Analyzer is "stand-by" (*3)

**only SWG100-BIOGAS.

Here means: 0= Open / 1=Closed.

Connecting an external control through four 4-20 mA input signals

The 4-bit status number is formed by four 4...20 mA signals. I4-I3-I2-I1 are:
0-11 mA = 0 signal (low) / 11/12-20 mA = 1 signal (high).

General settings	
LCD brightness	60 %
Country	International
Language	English
Keyboard beep	ON
Request admin-PIN	OFF
Service message	OFF
External control	4 x mA
Thresh.cond.alarm [kΩ]	80
Gas cooler	5°C

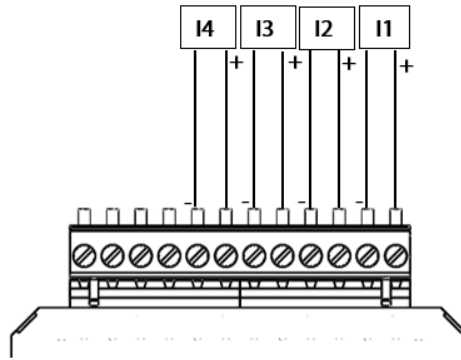

Status of external signal source				Status number	Description
I4	I3	I2	I1		
0	0	0	0	0	Automatic sampling point switching
0	0	0	1	1	Analyzer is sampling the point SP1 (*1, *2)
0	0	1	0	2	Analyzer is sampling the point SP2 (*1, *2)
0	0	1	1	3	Analyzer is sampling the point SP3 (*1, *2)
0	1	0	0	4	Analyzer is sampling the point SP4 (*1, *2)
0	1	0	1	5	Analyzer is sampling the point SP5 (*1, *2)
0	1	1	0	6	Analyzer is sampling the point SP6 (*1, *2)
0	1	1	1	7	Analyzer is sampling the point SP7 (*1, *2)
1	0	0	0	8	Analyzer is sampling the point SP8 (*1, *2)
1	0	0	1	9	Analyzer is sampling the point SP9 (*1, *2)
1	0	1	0	10	Analyzer is sampling the point SP10 (*1, *2)
1	0	1	1	11	Analyzer is "stand-by" (*3)
1	1	0	0	12	Purge phase for H2S-low-sensor **
1	1	0	1	13	Auto-Calibration
1	1	1	0	14	Remote reset of all system alarms
1	1	1	1	15	Analyzer is "stand-by" (*3)

Connecting an external control 4-20 mA input signal (via one input)

The user has the possibility to control the analyser externally by only one input signal (see sketch below). Different commands are given by the current level at measurement input I1. The zero signal corresponds to 4 mA. Each 1 mA level describes a state. Thus, the external control can assume up to 16 states. The first state corresponds to 5 mA (4 mA+1 mA) the second to 6 mA (4 mA+2mA) etc. until the signal reaches 20 mA.

General settings	
LCD brightness	60 %
Country	International
Language	English
Keyboard beep	ON
Request admin-PIN	OFF
Service message	OFF
External control	1 x mA
Thresh.cond.alarm [kΩ]	80
Gas cooler	5°C

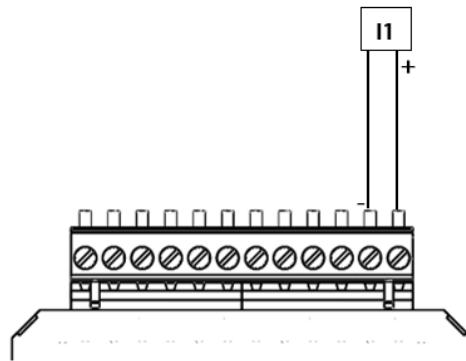

Status der externen Signalquelle	Status Nummer	Bechreibung
4	0	Automatic sampling point switching
5	1	Analyzer is sampling the point SP1 (*1, *2)
6	2	Analyzer is sampling the point SP2 (*1, *2)
7	3	Analyzer is sampling the point SP3 (*1, *2)
8	4	Analyzer is sampling the point SP4 (*1, *2)
9	5	Analyzer is sampling the point SP5 (*1, *2)
10	6	Analyzer is sampling the point SP6 (*1, *2)
11	7	Analyzer is sampling the point SP7 (*1, *2)
12	8	Analyzer is sampling the point SP8 (*1, *2)
13	9	Analyzer is sampling the point SP9 (*1, *2)
14	10	Analyzer is sampling the point SP10 (*1, *2)
15	11	Analyzer is "stand-by" (*3)
16	12	Purge phase for H2S-low-sensor **
17	13	Auto-Calibration
18	14	Remote reset of all system alarms
19	15	Analyzer is "stand-by" (*3)

General notes on external control

Case 1: Stand-by

The stand-by mode is activated when the status number exceeds the number of installed measuring points (example: 4 installed measuring points and active status number is 5). A stand-by mode has the following sequence:

- Purging via zero gas connection (depends on configured time).
- Stand-by mode until a status number is entered that corresponds to an installed measuring point.

Case 2: Active external control for a measuring point

- Zero point: First a zero point is taken. The running time of the zeroing can be set in the ext.Str menu.
- Gas aspiration: During the gas aspiration phase, the entire system is purged with sample gas to reach the T90 time of the analyser.
- Measurement: The measurement is started after the "gas aspiration" phase. The unit remains in measurement mode until the signal from the external control is changed. The table below shows the possible status numbers that can be assumed by the analyser.

(*1): Each time the measuring point is changed, the analyser takes a zero before measuring at the next measuring point.

(*2): Not only 11 to 15, but all status numbers greater than the number of installed measuring points will start the "stand-by" status.

(Example: if there are 4 measuring points, status numbers 5 to 15 will be set to "stand-by").

(*3): When the status number changes to a "stand-by" number, the sensors are purged, all solenoid valves are closed and the gas pump is switched off. If the status number changes to a smaller or the same number of installed measuring points, then a zeroing cycle begins and then measurement starts at the selected measuring point.

NOTE

The "stand-by" status can simply be used to start only one zero point measurement without "stand-by" and without changing the measuring point.

Example: - Status number=1 (for each time period, recommended max. 1 hour)

- Status number=15 (for a few seconds, recommended min. 10 seconds).

9.2 Option: Profibus-converter

The Profibus converter allows a direct communication between Modbus (RTU) and a Profibus interface.

- The option is only available from firmware V1.01.70.
- Transfer multibyte values in Motorola[®] Order (Big Endian).
- CRC16 at the end of each frame is transmitted with Intel[®] Order (Little Endian). In case the master system needs Little Endian Order.
- 16bit values in frame swap bytes 01.
- 32bit values in data swap byte 03 and bytes 2.
- All addresses shown here are decimal and not hexadecimal.
- All readable addresses are 32bit values.
- The meter accepts for reading only even addresses and even register numbers.

The data types used are:

- U32: 32 bit unsigned integer values (0...4,292,967,259).
- FL: 32 bit floating point values (reads -1E38 if not included).
- Some values are only optional (e.g. gas cooler).

The data types used are:

- U32: 32 bit unsigned integer values (0...4,292,967,259).
- FL: 32 bit floating point values (reads -1E38 if not included).
- Some values are only optional (e.g. gas cooler).

9.2.1 Connect device with Profibus

Prerequisite

- 9-Pin SUB connector cable.

9.2.2 Connection to device

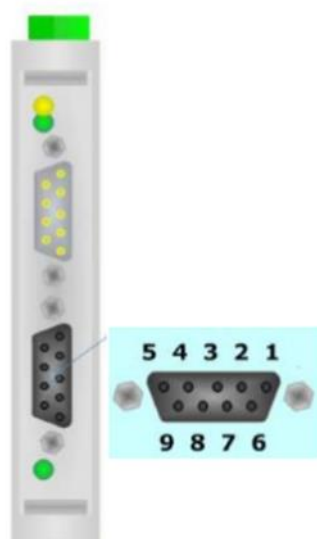

03 = Connection A, 04 = , 05 = GND (insolate Ground), 06 = Positiv Connection, 07 = , 08 = Connection B

9.2.3 Device settings

The settings are as followed:

Under the menu EXTRAS/GENERAL SETTINGS → MODBUS (F3) set the parameters.

The request parameters rise by a correct connection.



Modbus-Slave-Einstellungen	
Baudrate	19200
Slave-Adresse	238
Stoppbits	1
Parität	gerade
Datenbits	8
Anfragenanzahl	1425
zurück	

9.2.4 Special information about Modbus-Slave function

The device can work as a Modbus slave via RS232 or RS485 (possible with an external RS232/RS485 adapter).

- Supports RS485 interface with 2/4 wire function (half/full duplex).
- Supports Modbus binary protocol (RTU) only.
- Supports the Modbus command Read Holding Register (command no. 3).
- Supports the Modbus command Read Input Register (command no. 4).
- The slave Modbus address can be set by the user between 1 and 238.

The communication parameters can be defined by the user as follows:

- 9600 or 19200 baud (recommend 19200)
- Even , odd or none parity
- 1 or 2 Stopp-Bits.
- With a read command max. 63 32-Bitvalues can be read (126 Modbus registers).

9.2.5 Special information about Profibus – Slave function

- The Profibus slave function requires a Modbus Profibus converter "Seneca HD67561" installed and configured in the measuring device.
- The Profibus ID is normally set to 84 by MRU.

9.3 TCP to Modbus RTU Converter

PREREQUISITE:

- Micro USB cable.
- Ethernet cable
- Seneca Software Device Discovery or Software Easy-Setup (included on SD card).
- MRU4Win or Modbus Poll software.

9.3.1 Ethernet different states

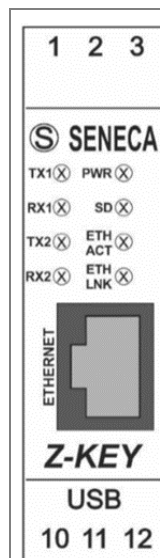

LED	Status	Description
TX1	---	No connection
RX1	---	No connection
TX2 (Red)	Flashing	Data reception at port # 2 RS485
RX2 (Red)	Flashing	Data reception at port # 2 RS485
PWR (Green)	On	Power on
SD (Red)	Flashing	Access to Mirco SD card
ETH ACT (Green)	Flashing	Übertragung an Ethernet Port
ETH ACT (Green)	On	No activity on Ethernet port
ETH LNK (Yellow)	On	Connected to Ethernet port
ETH LNK (Yellow)	Off	No Ethernet connection

9.3.2 Setting up Ethernet

The first step is to connect the TCP/RTU Modbus converter. 1.

▶ Switch on the unit.

▶ Connect the converter module to the network.

The power LED of the converter module will light up. In the next steps, configure the module with the programme "Seneca Discovery Device".

▶ Start the programme "Seneca Discovery Device".

▶ Press the "Scan..." button.

The converter is searched for in the network and indicated in the list.

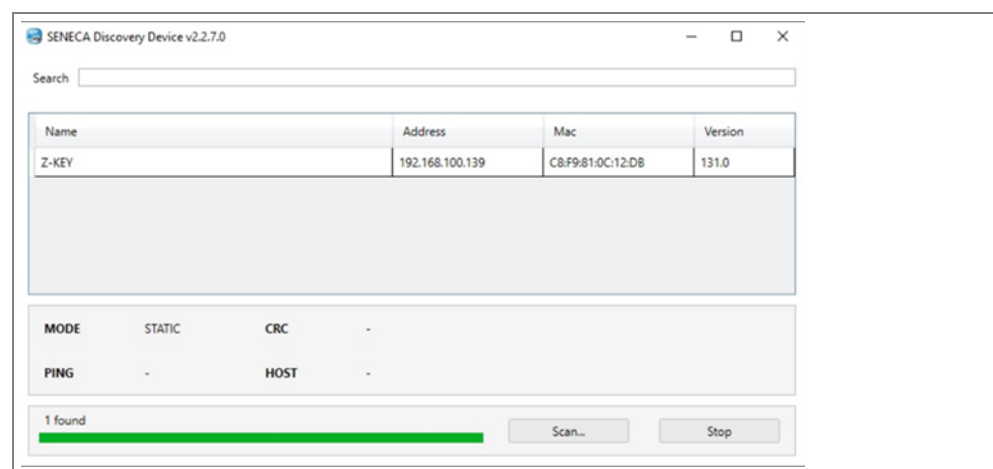

▶ The "Assign IP" button appears after the scan. Press the "Assign IP" button.

An input window appears.

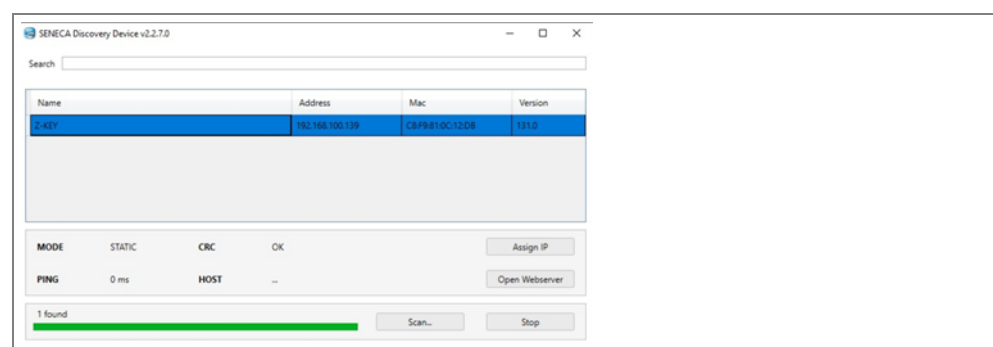

▶ Enter the IP address, submask and gateway in the input window. Alternatively, you can activate DHCP.

▶ Press the "Open Webserver" button.

The web server opens.

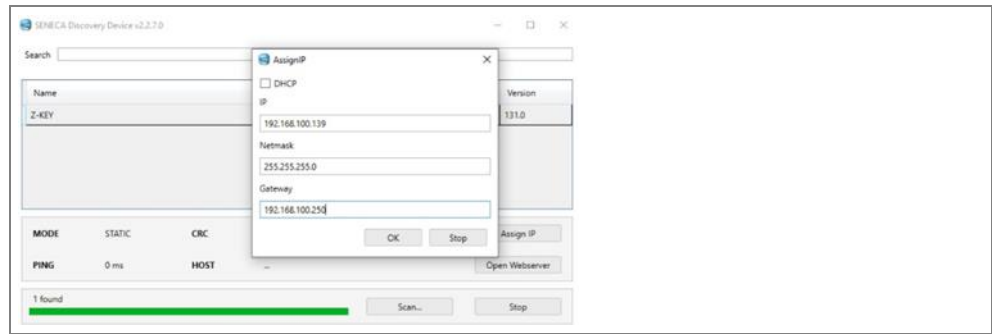

- ▶ Enter the user name "admin" and the password "admin".
An input field appears in which you can make the settings.
- ▶ Go to the menu "Setup".
- ▶ In this setting field, enter both the TCP data and the Modbus RTU data of your unit.

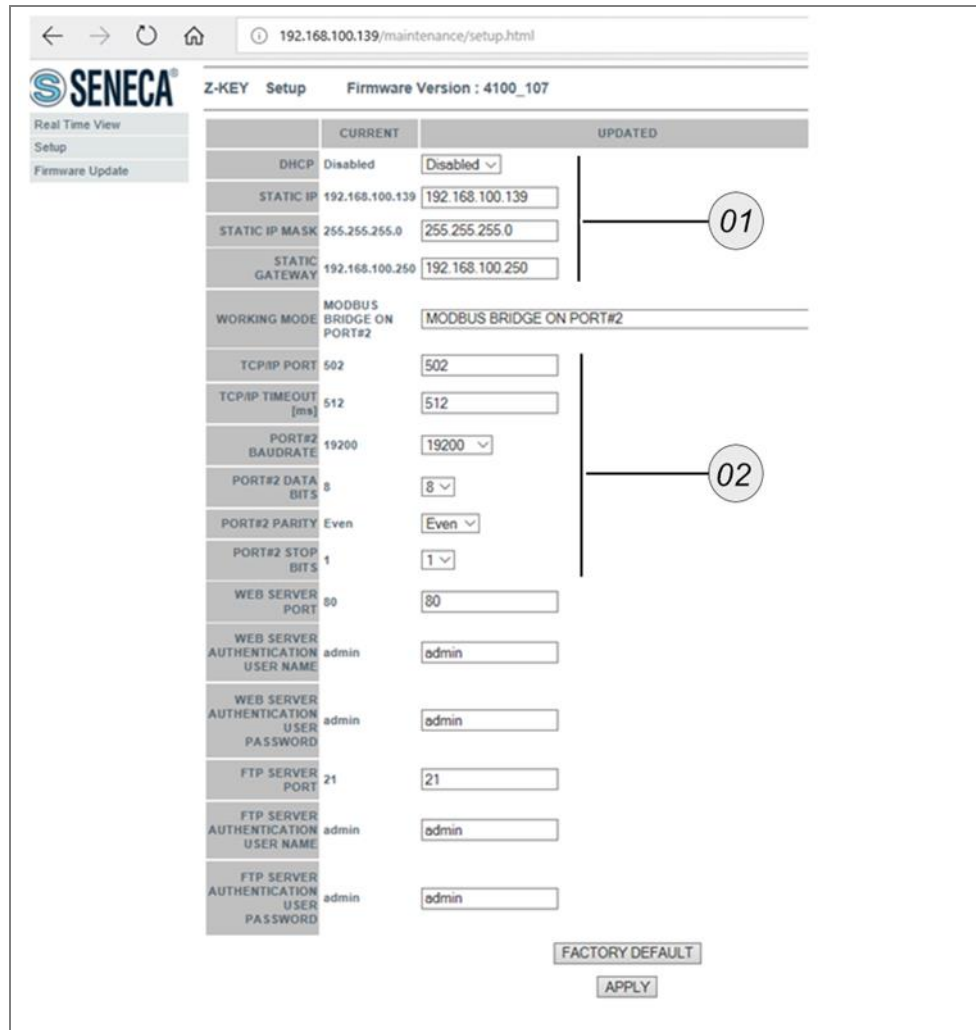

#	Description
1	Enter TCP data: IP address, submask, gateway
2	Enter RTU data of device: baud rate, stop bits, parity, data bits.

In the next step, adjust the Modbus RTU settings on the device.

- ▶ Open the menu EXTRAS / GENERAL SETTINGS F3 = MODBUS.
- ▶ In this menu, adjust the Modbus RTU settings so that the settings match the RTU settings on the web server.
- ✓ The converter is set. The counter counts up in the Modbus window.

9.4 Option: RS-485 to USB converter

The RS485/USB converter enables the communication of the device via the Modbus location with a RS-485 compatible device. The receiving device can be e.g. a normal PC.

9.4.1 RS-485 Converter connection and configuration

STEPS:

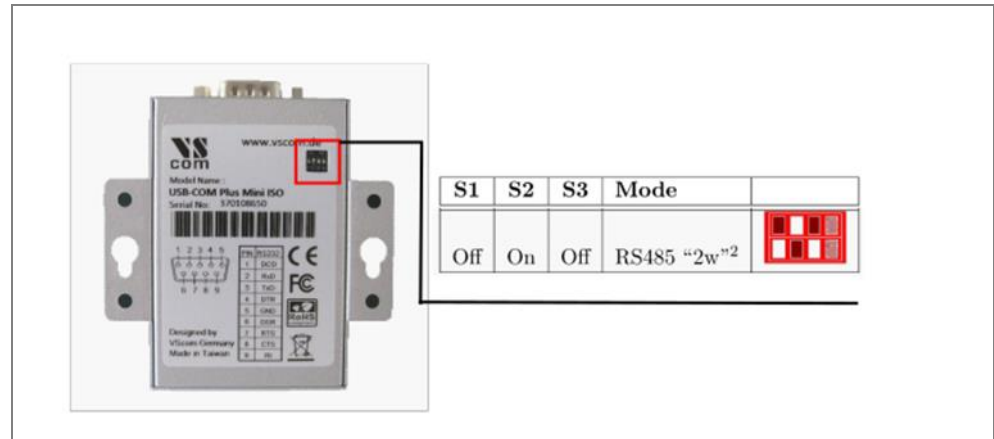

Fig. 1

- ▶ Set the DIP switch to RS-485 mode. The DIP switch is located on the back of the RS converter (Fig.1).

NOTE

Install the USB driver on the computer. The driver is already installed on most PCs. The driver can be downloaded from the homepage: <http://www.visionsystems.de/produkte/usb-com-plus-mini-usb-com-plus-mini-iso.html>.

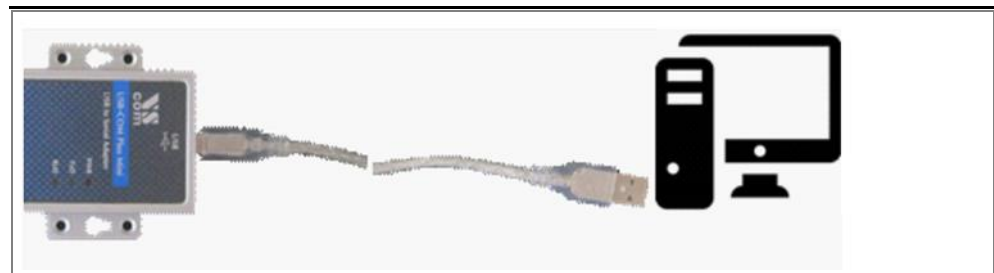

Fig.2

- ▶ Connect the RS-485 converter with an USB cable to the PC (Fig. 2).

The PC recognise the RS-485 converter. You can find the device in the device management of the PC.

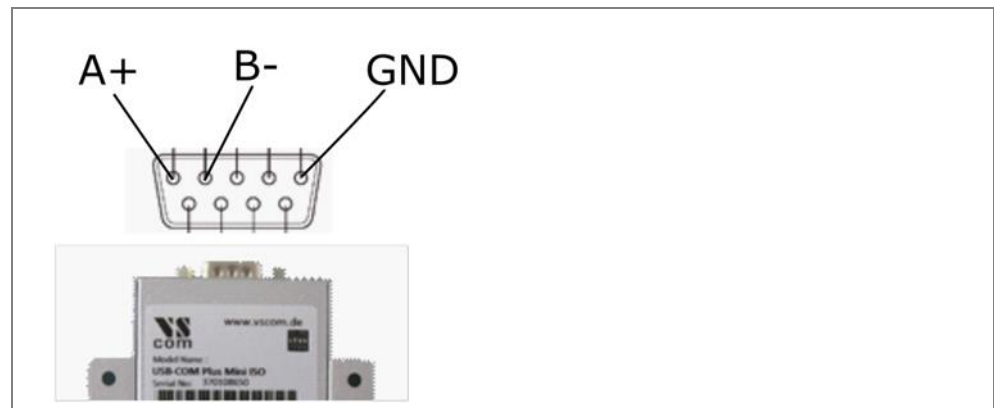

Fig. 3

- ▶ Connect the RS485- converter with the device. The connection will be built between the converter and the PC (Fig. 3).
- ▶ Open the menu Extras on the device: EXTRAS/GENERAL SETTINGS
- ▶ Open the submenu Modbus (F3).
- ▶ Make the settings into the menu. These includes: Baudrate, parity, Stop- Bits etc.
- ✓ The device is connected to the RS- 485 converter.

NOTE

Data can be viewed and logged by suitable software on the PC. If you do not have software, you can buy and use the MRU4Win software.

9.5 Option: auto calibration

With the auto-calibration option, your unit can carry out an adjustment automatically at predefined time intervals.

9.5.1 General warnings

⚠ WARNING

High pressure

Gas cylinders are under high pressure. High pressure can lead to injuries and death.

- Only trained persons may connect and operate gas cylinders.

⚠ WARNING

Trained staff

- Only trained personnel may install gas cylinders.

PREREQUISITES:

- Adjustment gas cylinders with your calibration gas.
- The option „Auto calibration“ must be installed.

STEPS: INSTALL ADJUSTMENT GAS CYLINDERS

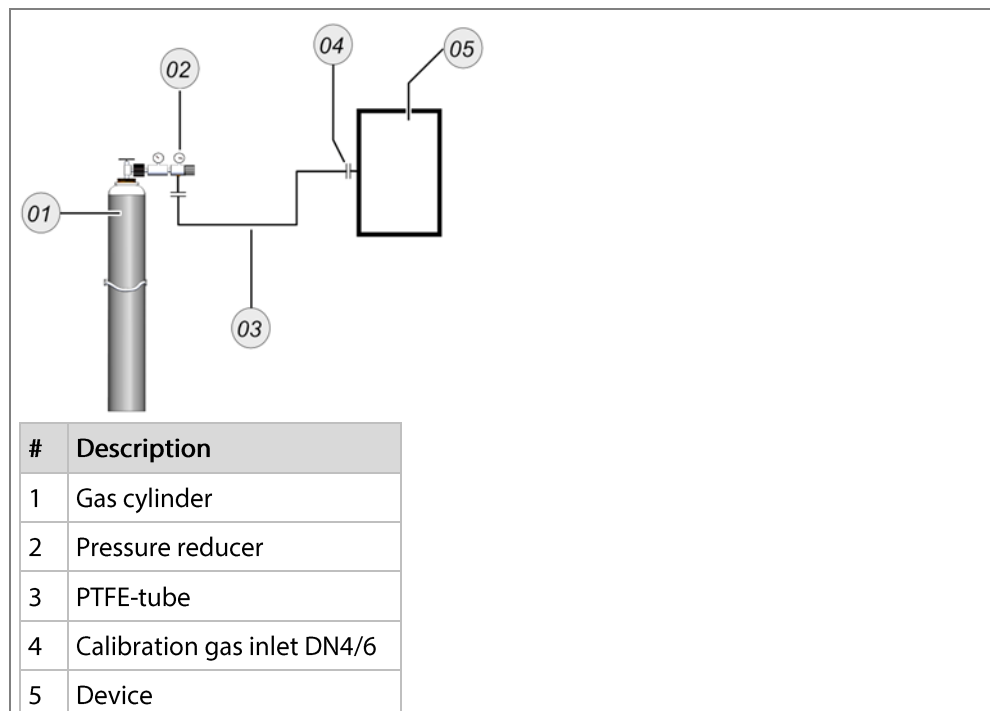
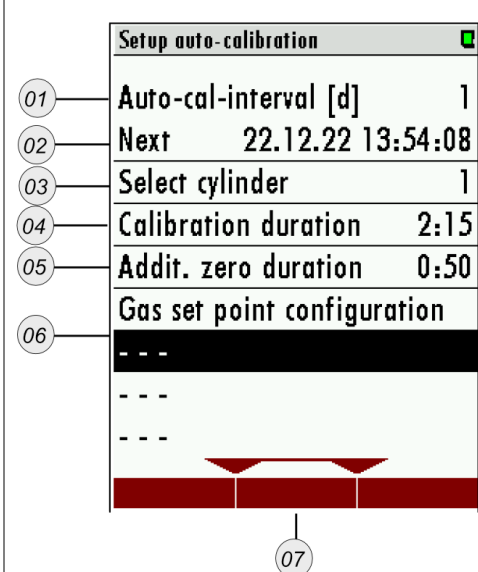

Fig.1

- Connect the adjustment gas cylinder to *Calibration gas inlet 1*, *Calibration gas inlet 2*, etc. (Fig.1)

STEPS: SETTINGS



#	Description	#	Description
1	Set Auto-cal-interval	2	Next date
3	Select of gas cylinder	4	Calibration duration
5	Additional zero duration	6	Gas set point configuration

Fig. 1

- ▶ Open the menu: EXTRAS / ADJUSTMENT MENU / AUTO CALIBRATION (Fig.1).
 - ☞ Structure of menu-point see (Fig.1 (1-7)).
 - ▶ Use the **left/right arrow keys** (←→) to set for which Calibration gas inlet (1 to max. 5) the settings should apply (Fig.1 (3)).
 - ▶ Use the **left/right arrow keys** (←→) to set your desired auto calibration interval (Fig.1 (4)).
 - ▶ Use the **left/right arrow key** (←→) to set the date and time for the start of the interval (Fig.1 (2)).
 - ▶ Use the **left/right arrow key** (←→) to set your desired calibration period (Fig.1 (1)).
- Set your desired zero point duration **5** with the **left/right arrow keys** (←→) (Fig.1 (5)).

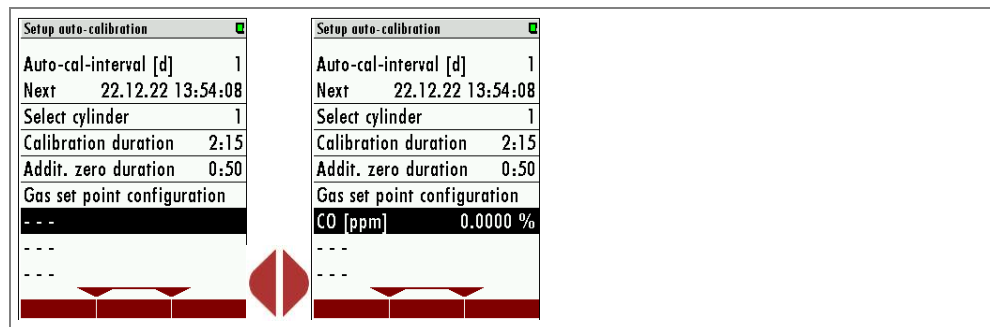

Fig.2

- ▶ Go to the list "GAS SET POINT CONFIGURATION" (Fig.2).
- ▶ Select the first gas component of your adjustment gas cylinder with the *left/right arrow key* (←→).
- ▶ Press the **OK**-key to set the setpoint.

A blue input window appears.

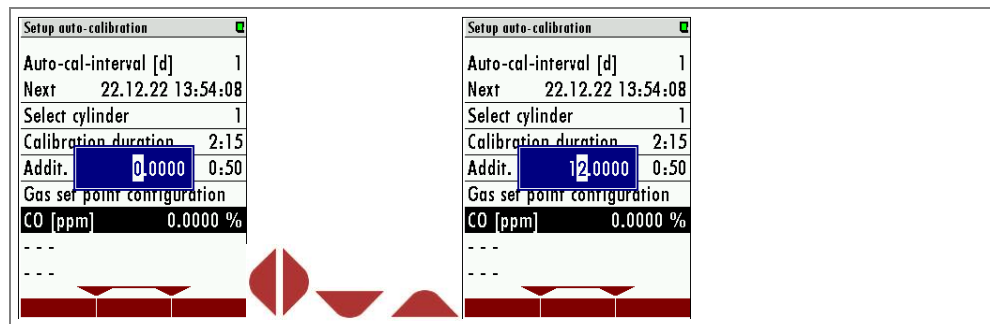

Fig.3

- ▶ Use the *arrow keys* to set the setpoint of the gas component in the blue input window.
- ▶ Press the **OK**-key to confirm the entry.
- ▶ Continue with the steps to enter all gas components in the adjustment gas cylinder in list **6**.
- ▶ Carry out the same steps for any other adjustment bottles.
- ✓ You have configured the auto adjustment.
 - i** If you want to start the adjustment as specified, exit the menu and confirm the settings.
 - i** If you want to start the auto calibration immediately, press **F2** = **START NOW** **7**.

9.6 Option: MRU4Win

MRU4Win is a log software. Through the software you can log and save data from the device. The software can detect devices with TCP protocol and RS-485 Modbus protocol (RTU).

9.6.1 MRU4Win start and settings

PREREQUISITE:

- The device must be connected to a suitable converter and be able to communicate.

STEPS:

- ▶ Open the software on your PC. 2.

- ▶ Open "Create Modbus Device".

An input window appears in which you can select the respective protocol.

- ▶ For RS-485: select Modbus RTU. Set the same settings here as in the device. Baud rate, parity etc. must match.

- ▶ For TCP: select TCP. Set here the same settings as in the device. IP address, submask etc. must match.

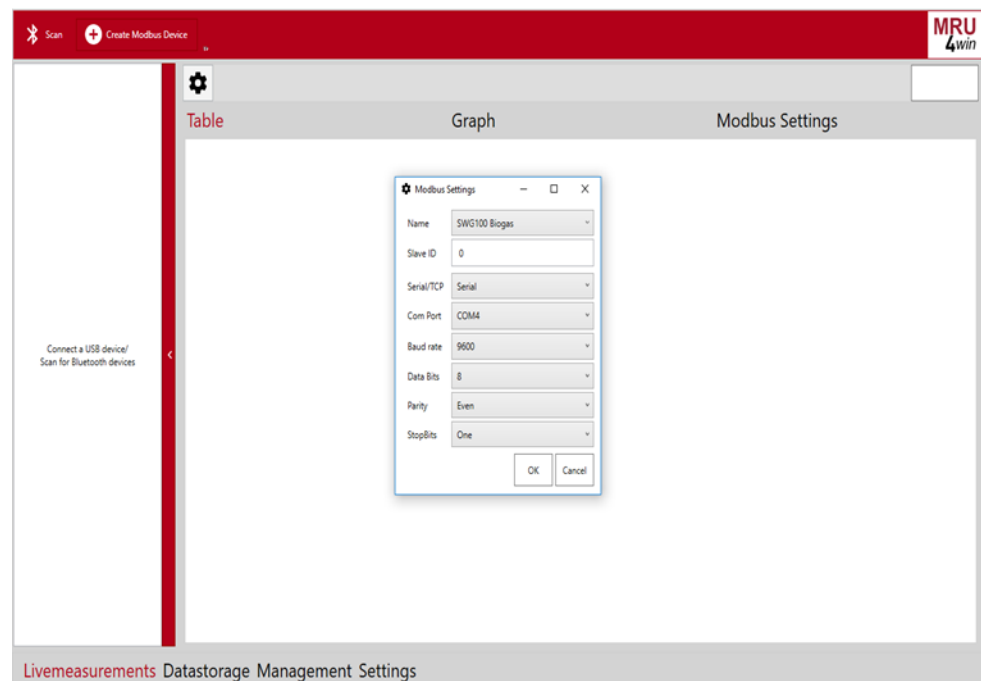

The connected device is displayed on the left side.

- ▶ Press the Connect icon.

- ▶ The live values from the device are visible on the PC. The values can be displayed as a curve or as a number. Logging and saving is possible.

10 Technical data

10.1 General technical data

Deutsch	Daten / Data	English
Betriebstemperatur(ohne Frostschutzheizung)	+5°C ... +45 °C / 41 °F ... 113 °F	Operating temperature (w/o heating)
Betriebstemperatur (mit optionaler Frostschutzheizung)	-10 °C ... +45°C / 14 °F ... 113 °F	Operating temperature (with internal heating, option)
Rel. Luftfeuchtigkeit bei Betrieb, nicht-kondensierend	< 95%	Rel. Humidity, non-condensing
Lagertemperatur	-20°C ... +50°C / -4°F ... 122°F	Storage Temperature
Schutzart	IP54	Protection Class
Aufstellbedingungen	geschützt vor direkter Sonneneinstrahlung und Regen / do not expose to direct sun light or rain	Installation Requirements
Geeignet für Ex-Zone	nein / no	suitable for Ex Zone
Stromversorgung ohne Sonde und Heizschlauch	100 - 240 V, 200 W	Power supply without heated sample line and probe
Gewicht, typisch mit Sensoren, Gaskühler	50 kg / 105 lbs	Weight, typically incl 2 sensors
Maße (HxBxT)	700x600x210 mm 23.6x 27.6 x8.3 in	Size (HxWxL)
Gehäusematerial	Edelstahl Rostfrei stainless steel	Housing material
max. Unterdruckbereich der Gaspumpe	300 hPa	Max suction range gas pump
zulässiger Überdruck am Gaseingang (ausstattungsabhängig)	200 hPa	Permissible overpressure at gas inlet (depending on equipment)
typischer Gasdurchfluss	50 l/h	gas flow typ.

10.2 Technical data: NDIR-bench

Gas	Comment	Measuring range 0 - min ... max	Resolution	Repeatability	8h-Drift	Linearity
NO		0 - 200...4.000 ppm	0,1 ppm	2 ppm / 1% rdg.	2 ppm / 1% rdg.	1% m.r.
NO ₂	without H ₃ PO ₄	0 - 300 ... 1000 ppm	0,1 ppm	5 ppm / 1% rdg.	5 ppm / 1% rdg.	1% m.r.
	with H ₃ PO ₄	0 - 150...1000 ppm	0,1 ppm	1 ppm / 1% rdg.	2 ppm / 1% rdg.	1% m.r.
SO ₂	without H ₃ PO ₄	0 - 300...4.000 ppm	0,1 ppm	5 ppm / 1% rdg.	5 ppm / 1% rdg.	1% m.r.
	with H ₃ PO ₄	0 - 150...4.000 ppm	0,1 ppm	2 ppm / 1% rdg.	2 ppm / 1% rdg.	1% m.r.
CO ₂		0 - 40 Vol%	0,01 Vol%	0,2 Vol% / 1% rdg.	0,2 Vol% / 1% rdg.	1% m.r.
CO		0 - 175...10.000 ppm	0,1 ppm	2 ppm / 1% rdg.	2 ppm / 1% rdg.	1% m.r.
N ₂ O		0 - 100...500 ppm	0,1 ppm	2 ppm / 1% rdg.	2 ppm / 1% rdg.	1% m.r.
CH ₄		0 - 500...10.000 ppm	0,1 ppm	10 ppm / 1% rdg.	2 ppm / 1% rdg.	1% m.r.
C ₃ H ₈		0 - 200...5.000 ppm	0,1 ppm	2 ppm / 1% rdg.	2 ppm / 1% rdg.	1% m.r.

10.3 Technical data: electrochemical sensors

Technische Daten	O ₂ -Long Life #65419	Technische Daten
Elektrochemischer Sensor	O ₂ Long Life	Electrochemical Sensor
Messbereich	0 .. 21%	Measuring Range
Auflösung	0,01%	Resolution
Genauigkeit abs.	± 0,2 Vol%	Abs. Accuracy
Ansprechzeit T ₉₀	< 20s	Response Time T ₉₀
Jahre erwartete Lebensdauer an Luft	2	Years expected lifetime (@air)

Elektrochemischer Sensor	H2	Electrochemical Sensor
Nominaler Messbereich	0 - 1 Vol%	Nom. Measuring Range
Überlastbereich	< 2 Vol%	Overload Range
Auflösung	0,01 Vol%	Resolution
Genauigkeit abs. /vom Messwert	0,2 Vol% / 5%	Accuracy abs./reading
Ansprechzeit T90	< 90s	Response Time T90
Jahre erwartete Lebensdauer an Luft	2	Years expected lifetime (@air)

10.3.1 Different measurement techniques

Paramagnetischer Sensor	O ₂	Paramagnetic Sensor
Messbereich	0 Vol% ... 25 Vol%	Measuring Range
Auflösung	0,01 Vol%	Resolution
Genauigkeit	0,1 Vol%	Accuracy

11 Appendix

The appendix has the follow contents:

- Mechanical drawing
- Gas flow diagram
- Wiring diagram
- Position plan

11.1 Mechanical drawing

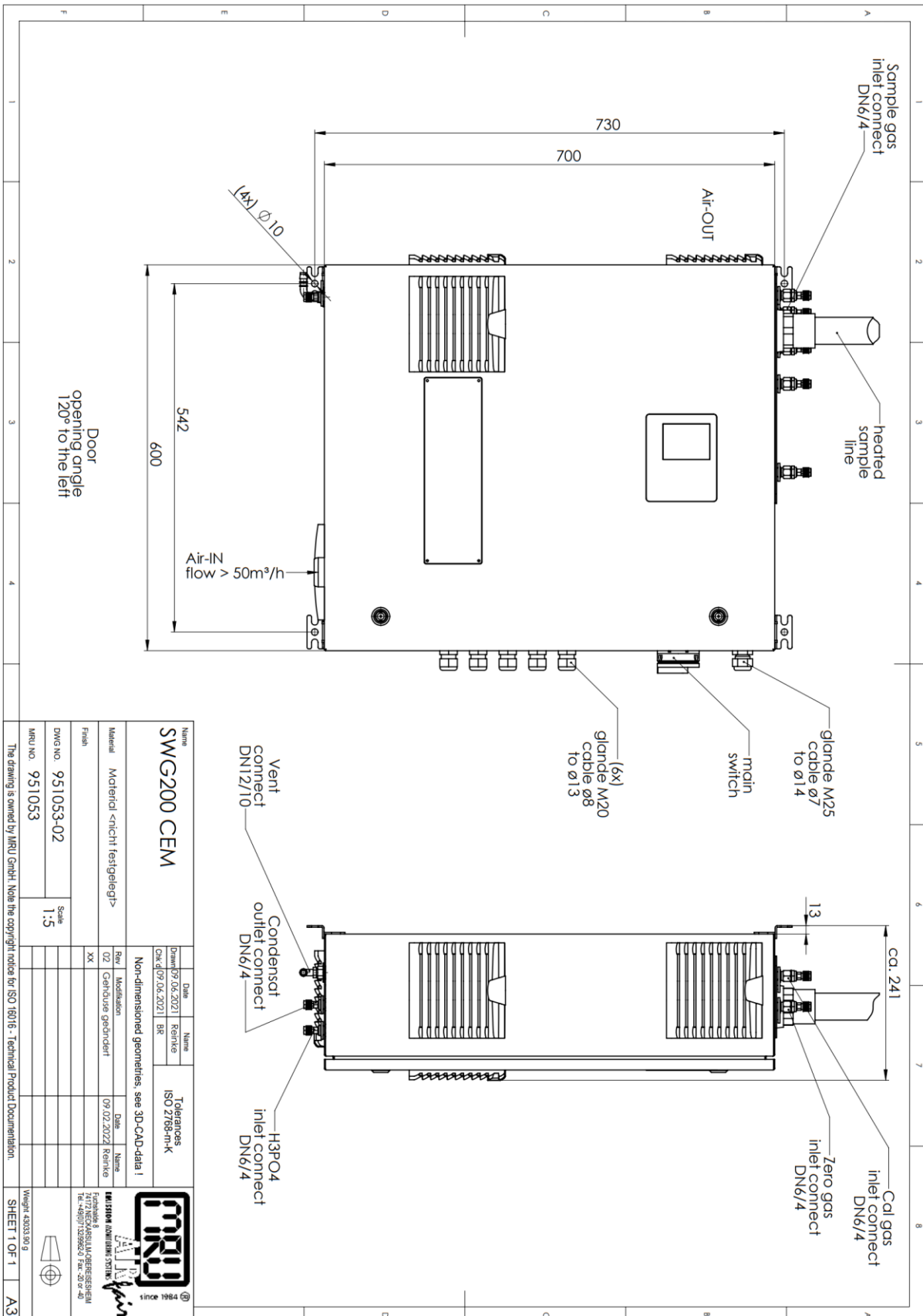

11.2 Gas flow diagram

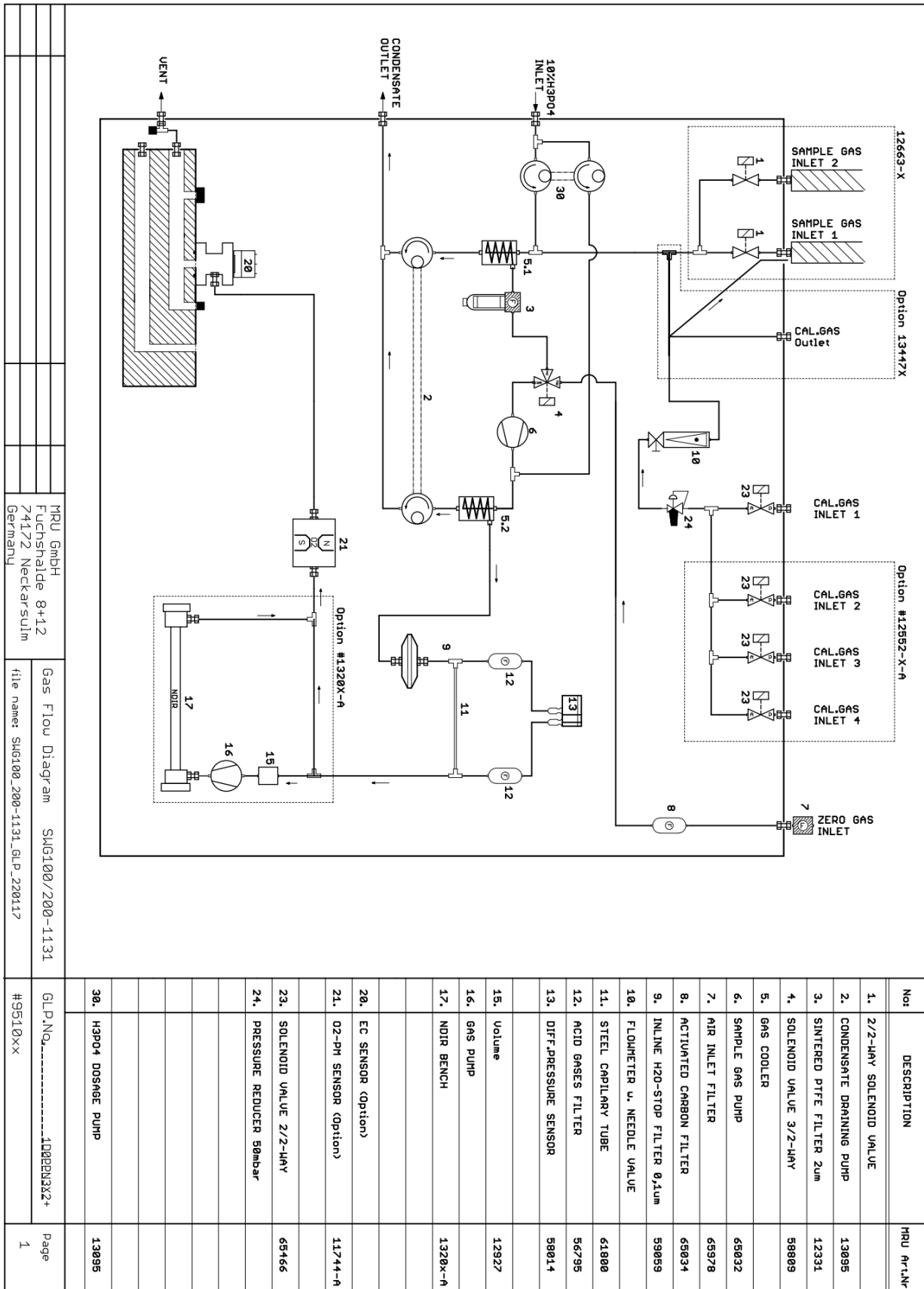

11.3 Wiring diagram

<p>MRU GmbH Fuchshalde 8+12 74172 Neckarsulm Germany</p>		<p>circuit diagram SMG200-1131 The circuit diagram is for 230V +-10%. SMG200CEM-1131</p>																																							
<p>table of content</p> <table border="1"> <tr> <th>page</th> <th>description</th> </tr> <tr> <td>1</td> <td>overview</td> </tr> <tr> <td>2</td> <td>Din Rail 1</td> </tr> <tr> <td>3</td> <td>Din Rail 1, heated sample line + AC-Probe</td> </tr> <tr> <td>4</td> <td>Din Rail 2</td> </tr> <tr> <td>5</td> <td>Din Rail 3</td> </tr> <tr> <td>6</td> <td>Din Rail 4</td> </tr> <tr> <td>7</td> <td>GKM (gas cooler pcb)</td> </tr> <tr> <td>8</td> <td>HMI, NDIR</td> </tr> <tr> <td>9</td> <td>EC-Sensors, PARANAG-02, TCD</td> </tr> <tr> <td>10</td> <td></td> </tr> </table>				page	description	1	overview	2	Din Rail 1	3	Din Rail 1, heated sample line + AC-Probe	4	Din Rail 2	5	Din Rail 3	6	Din Rail 4	7	GKM (gas cooler pcb)	8	HMI, NDIR	9	EC-Sensors, PARANAG-02, TCD	10																	
page	description																																								
1	overview																																								
2	Din Rail 1																																								
3	Din Rail 1, heated sample line + AC-Probe																																								
4	Din Rail 2																																								
5	Din Rail 3																																								
6	Din Rail 4																																								
7	GKM (gas cooler pcb)																																								
8	HMI, NDIR																																								
9	EC-Sensors, PARANAG-02, TCD																																								
10																																									
<p>Recommended supply line cross-sections and circuit breakers</p> <table border="1"> <tr> <td>heated supply lines up to 1.5km</td> <td>circuit breaker: 16A, cross section: 1.5mm²</td> <td>Angabe für Kunde, nicht für Produktion!</td> </tr> <tr> <td>heated supply lines up to 2.5km</td> <td>circuit breaker: 20A, cross section: 2.5mm²</td> <td>Angabe für Kunde, nicht für Produktion!</td> </tr> <tr> <td>heated supply lines up to 4.0km</td> <td>circuit breaker: 25A, cross section: 4mm²</td> <td>Angabe für Kunde, nicht für Produktion!</td> </tr> <tr> <td>heated supply lines up to 5.0km</td> <td>circuit breaker: 30A, cross section: 6mm²</td> <td>Angabe für Kunde, nicht für Produktion!</td> </tr> </table>				heated supply lines up to 1.5km	circuit breaker: 16A, cross section: 1.5mm ²	Angabe für Kunde, nicht für Produktion!	heated supply lines up to 2.5km	circuit breaker: 20A, cross section: 2.5mm ²	Angabe für Kunde, nicht für Produktion!	heated supply lines up to 4.0km	circuit breaker: 25A, cross section: 4mm ²	Angabe für Kunde, nicht für Produktion!	heated supply lines up to 5.0km	circuit breaker: 30A, cross section: 6mm ²	Angabe für Kunde, nicht für Produktion!																										
heated supply lines up to 1.5km	circuit breaker: 16A, cross section: 1.5mm ²	Angabe für Kunde, nicht für Produktion!																																							
heated supply lines up to 2.5km	circuit breaker: 20A, cross section: 2.5mm ²	Angabe für Kunde, nicht für Produktion!																																							
heated supply lines up to 4.0km	circuit breaker: 25A, cross section: 4mm ²	Angabe für Kunde, nicht für Produktion!																																							
heated supply lines up to 5.0km	circuit breaker: 30A, cross section: 6mm ²	Angabe für Kunde, nicht für Produktion!																																							
<p>wire colours</p> <table border="1"> <tr> <td>L</td> <td>BN or BK</td> </tr> <tr> <td>N</td> <td>BU</td> </tr> <tr> <td>PE</td> <td>GN/YE</td> </tr> <tr> <td>+ 12Vdc</td> <td>dark BU</td> </tr> <tr> <td>DC GND</td> <td>BU / MH</td> </tr> <tr> <td>unswitched / unfused line</td> <td>OR !! warning !!</td> </tr> </table>		L	BN or BK	N	BU	PE	GN/YE	+ 12Vdc	dark BU	DC GND	BU / MH	unswitched / unfused line	OR !! warning !!	<p>wire color code</p> <table border="1"> <tr> <td>BK</td> <td>black</td> </tr> <tr> <td>BN</td> <td>brown</td> </tr> <tr> <td>OG</td> <td>orange</td> </tr> <tr> <td>RD</td> <td>red</td> </tr> <tr> <td>YE</td> <td>yellow</td> </tr> <tr> <td>GN</td> <td>green</td> </tr> <tr> <td>BU</td> <td>blue</td> </tr> <tr> <td>UT</td> <td>violet</td> </tr> <tr> <td>GR</td> <td>grey</td> </tr> <tr> <td>MH</td> <td>white</td> </tr> <tr> <td>PK</td> <td>pink</td> </tr> <tr> <td>SR</td> <td>silver</td> </tr> <tr> <td>GD</td> <td>gold</td> </tr> </table>		BK	black	BN	brown	OG	orange	RD	red	YE	yellow	GN	green	BU	blue	UT	violet	GR	grey	MH	white	PK	pink	SR	silver	GD	gold
L	BN or BK																																								
N	BU																																								
PE	GN/YE																																								
+ 12Vdc	dark BU																																								
DC GND	BU / MH																																								
unswitched / unfused line	OR !! warning !!																																								
BK	black																																								
BN	brown																																								
OG	orange																																								
RD	red																																								
YE	yellow																																								
GN	green																																								
BU	blue																																								
UT	violet																																								
GR	grey																																								
MH	white																																								
PK	pink																																								
SR	silver																																								
GD	gold																																								
<p>DANGER: Some terminals are energized, even if the main switch is shut off. Always be sure to switch on the complete power supply before working on the unit The value of the fuses depend on the power consumption of the connected load.</p>																																									
<p>date</p> <table border="1"> <tr> <th>date</th> <th>revision</th> <th>name</th> </tr> <tr> <td></td> <td></td> <td></td> </tr> </table>		date	revision	name				<p>MRU SMG</p> <p>file name: UPL_SMG200-1131_230119 - Korea_T.Hespelt_Entwurf_1 #951053A</p> <p>editor: 19.01.2023 T.Hespelt checked: T.Hespelt</p> <p>date: 19.01.2023 name: T.Hespelt</p> <p>Page: 1/11</p>																																	
date	revision	name																																							

19.01.2023 15:50:38 f=0.67 O:\Produkte\SW\Gx00_1131\951053K_SW\G200-K_KOREA\Electrical diagrams\VP_L_SW\G200-1131_230119 - Korea_T.Hespelt_Entwurf_.sch (She



19.01.2023 15:50:38 F=0.67 O:\Produkte\SWGX00_1131\951053K_SWG200-K_KOREA\Electrical diagrams\VPL_SWG200-1131_230119 - Korea_T.Hespetl_Entwurf_sch (She

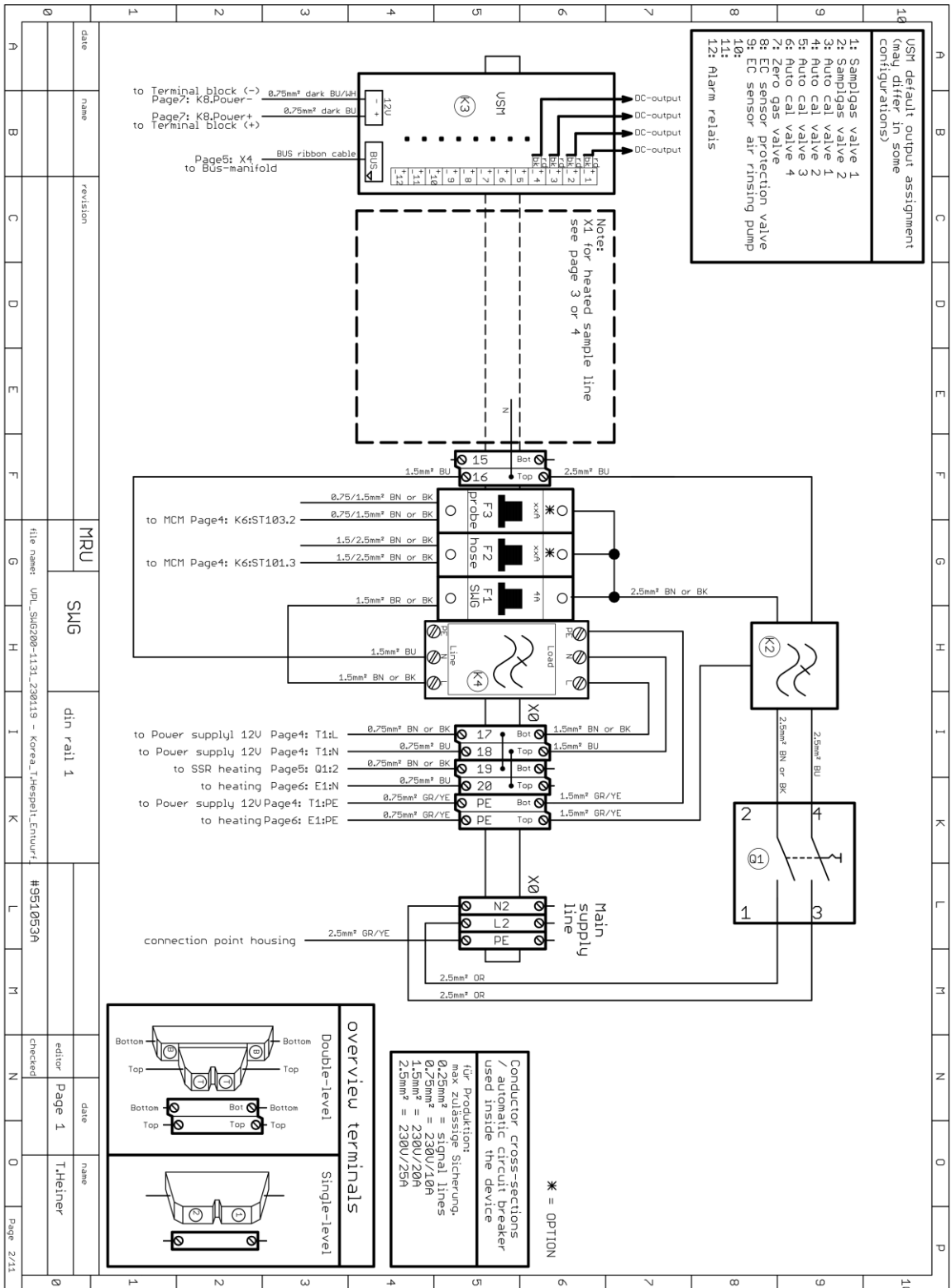

19.01.2023 15:50:38 f=0.67 O:\Produkte\SW\GX00_1131\951053K_SW\G200-K_KOREA\Electrical diagrams\VPL_SW\G200-1131_230119 - Korea_T.Hespelt_Entwurf_sch (She

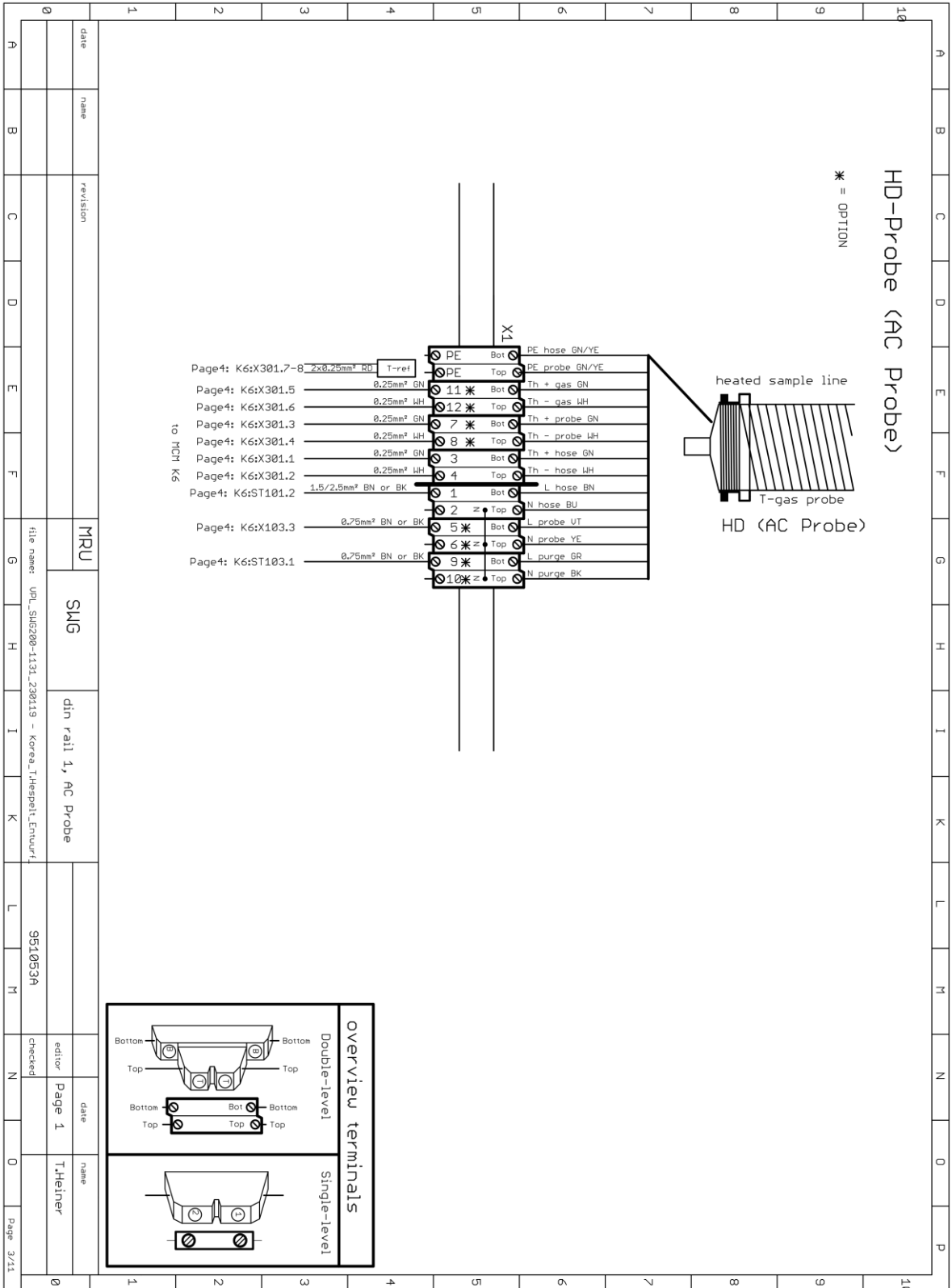

19.01.2023 15:50:38 f=0.67 O:\Produkte\SWGx00_1131\951053K_SWG200-K_KOREA\Electrical diagrams\VPL_SWG200-1131_230119 - Korea_T.Hespeit_Entwurf_sch (She

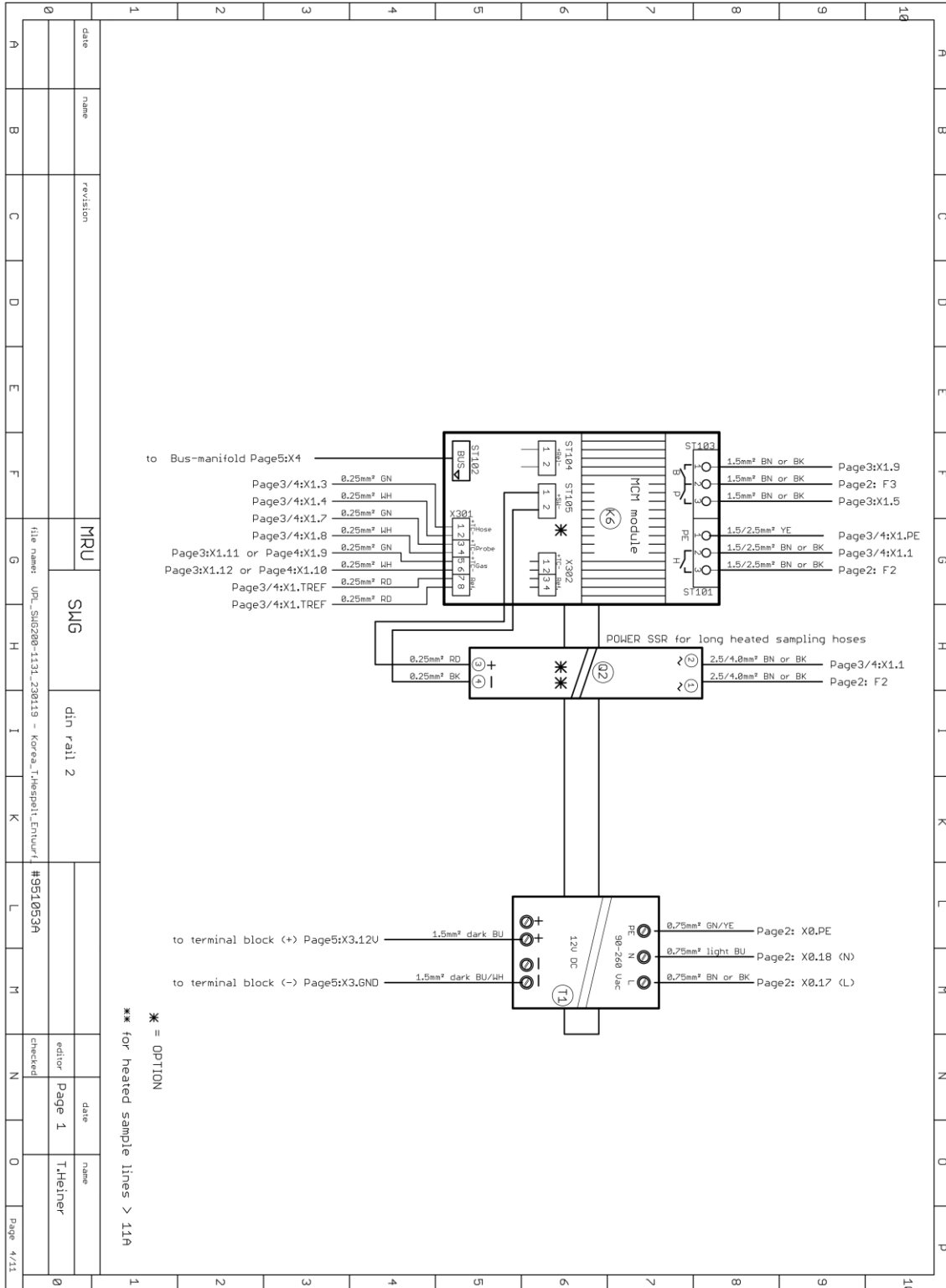

19.01.2023 15:50:38 F=0.67 O:\Produkte\SWG\X00_11311951053K_SWG200-K_KOREAElectrical diagrams\VP_L_SWG200-1131_230119 - Korea_T.Hespell_Entwurf_sch (She

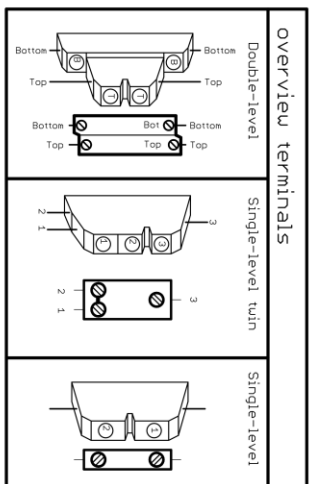
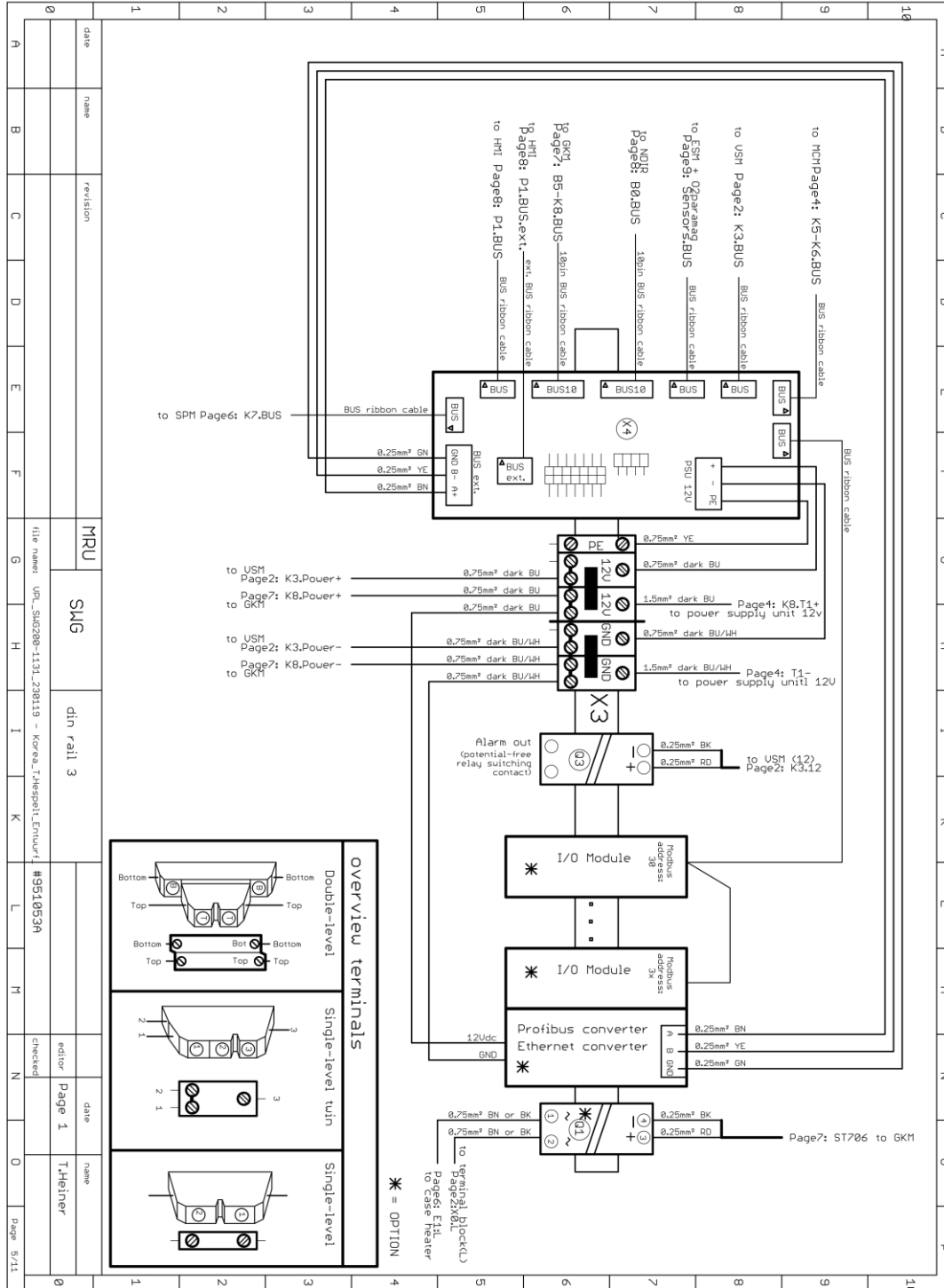

date	name	revision	MRU	SMG	din rail 3	date	name
						Page 1	T.Heiner
			file name: VP_L_SWG200-1131_230119 - Korea_T.Hespell_Entwurf_#951053K			editor	
						checked	
						date	
						name	
						Page 9/11	

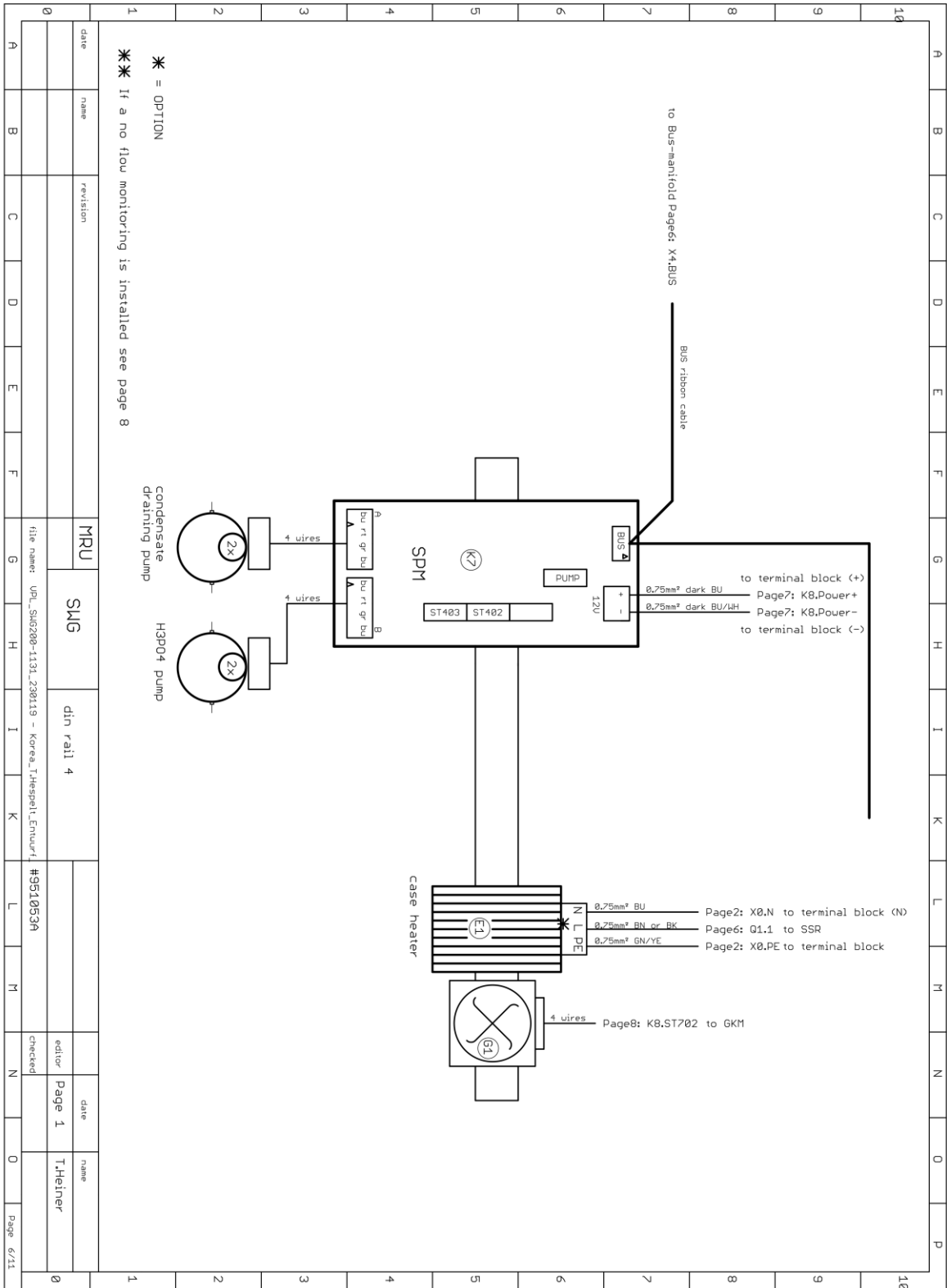

19.01.2023 15:50:38 f=0.67 O:\Produkte\SWGx00_11311951053K_SWG200-K_KOREA\Electrical diagrams\PL_SWG200-1131_230119 - Korea_T.Hespelt_Entwurf_sch (She

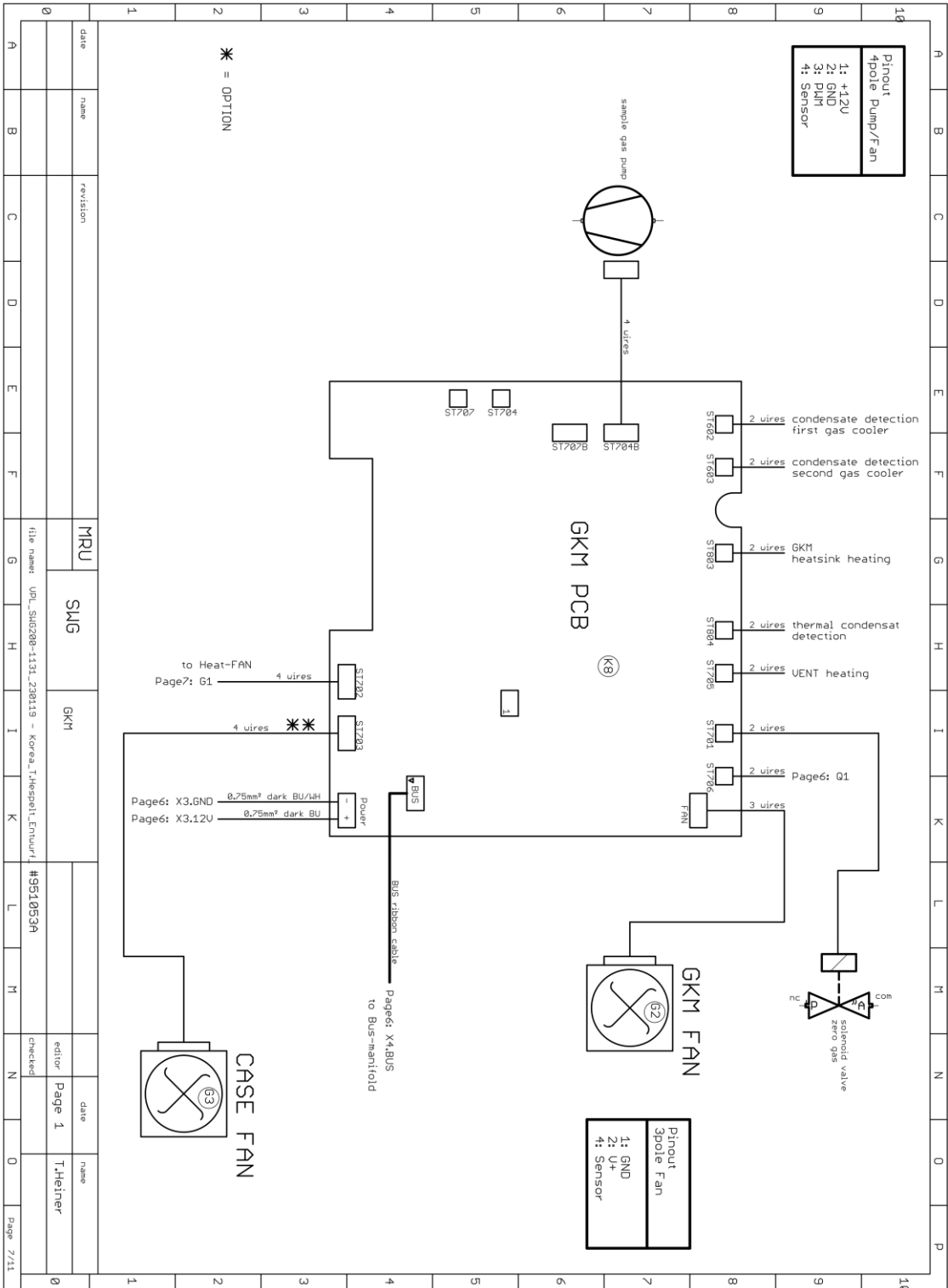

19.01.2023 15:50:38 f=0.67 O:\Produkte\SWGx00_11311951053K_SWG200-K_KOREA\Electrical diagrams\VP_L_SWG200-1131_230119 - Korea_T.Hespelt_Entwurf_.sch (She

19:01 2023 15:50:38 f=0.67 O:\Produkte\SWGx00_1131\951053K_SWG200-K_KORAElectrical diagrams\VPL_SWG200-1131_230119 - Korea_T.Hespelt_Entwurf_.sch (She

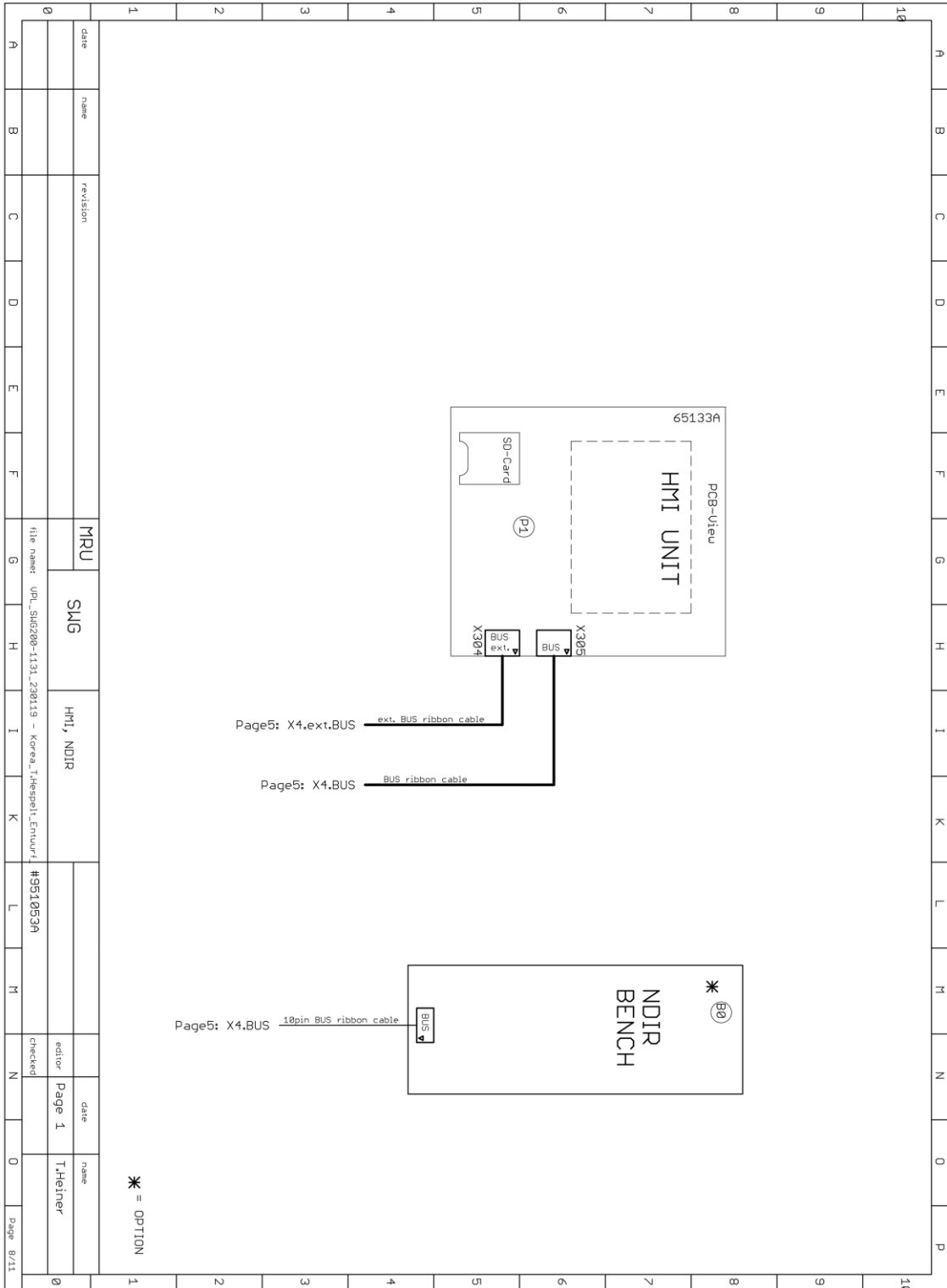

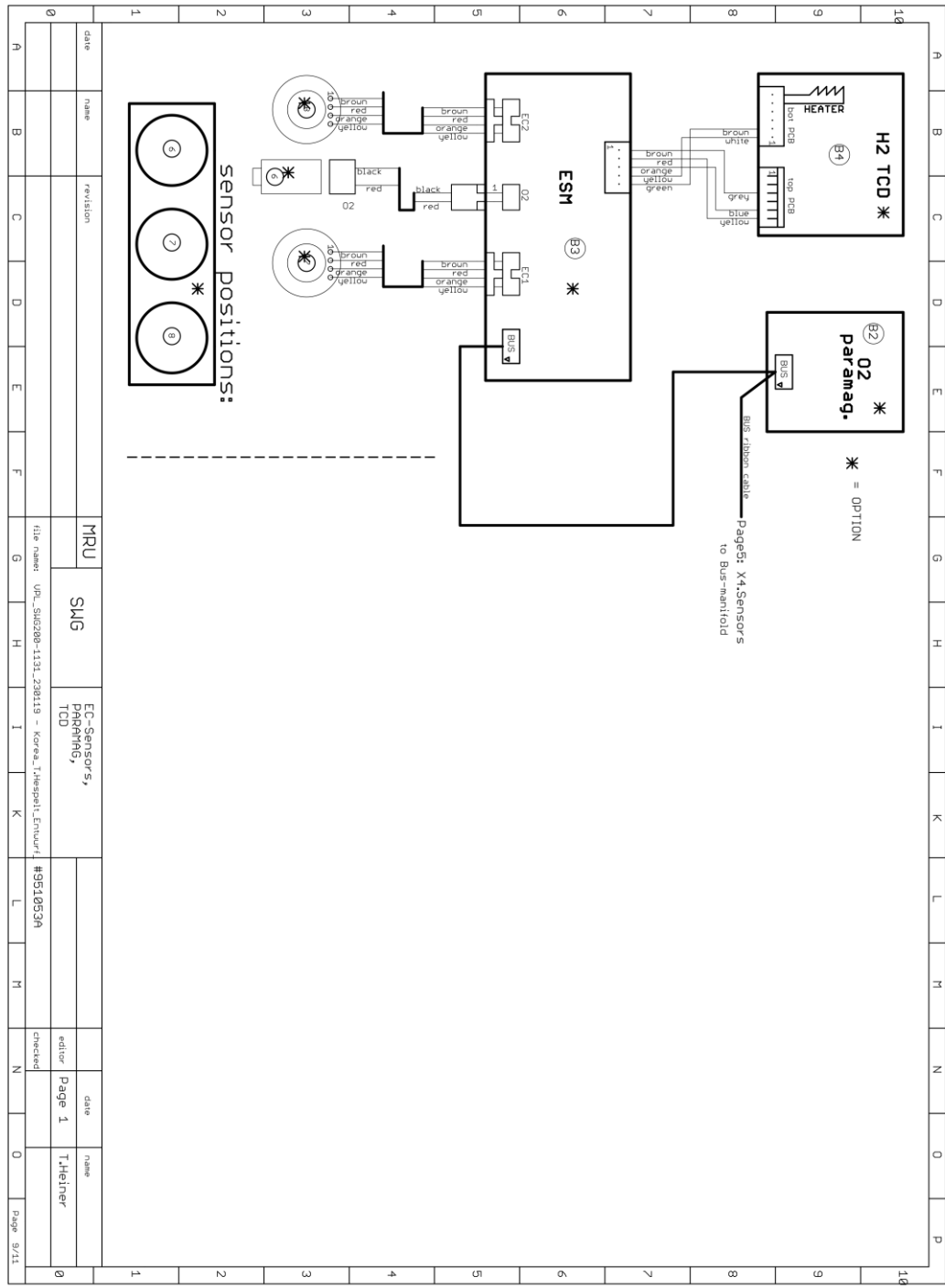

19.01.2023 15:50:38 f=0.67 O:\Produkte\SWGx00_1131\951053K_SWG200-K_KOREAElectrical diagrams\VP_L_SWG200-1131_230119 - Korea_T.Hespell_Entwurf_.sch (She

Components		mark	page	name/description
K3	2	UXM: Valve Control Modul		
Fx	2	Circuit Breaker*		
Kx	2	Line Filter		
Q1	2	Main switch		
X0	2	Terminal block		
X1	3	Terminal block (HD- Probes/Lines)*		
T1	4	Power Supply Unit 12V		
K5	4	MCM: Sample line and probe controller*		
Q2	4	solid state relay for long heated sampling lines*		
X4	5	bus distribution module		
X3	5	Terminal block (12V DC)		
Q3	5	Alarm relay		
Q1	5	I/O Modules, Bus converter*		
	5	Solid state relay for heating*		
K7	6	SPM: Peristaltic pump controller		
E1	6	case heater*		
G1	6	case heater fan*		
G3	7,8	case fan*		
K8	7	Gas cooler pcb		
G2	7	fan for heatsink*		
G4	7	interrral fan*		
G3	7,8	case fan*		
P1	8	HMI (Human machine interface)		
B0	8	NDIR Bench*		
B4	9	H2-Sensor (TCD)*		
B2	9	O2-Sensor Paramag.*		
B3	9	ESM: Sensor Module*		
B1	9	Main pcb*		

* = OPTION

date	revision	MRU	SMG	file name: URL_SMG200-1131_230119 - Korea_Thespeil_Entwurf_	#351053A	editor	date	name
						Page 1		T.Heiner
						checked		

19.01.2023 15:50:38 F=0.67 O:\Produkte\SWG_X00_1131\951053K_SWG200-K_KOREAElectrical diagrams\PL_SWG200-1131_230119 - Korea_Thespeil_Entwurf_sch (She



11.4 Position plan

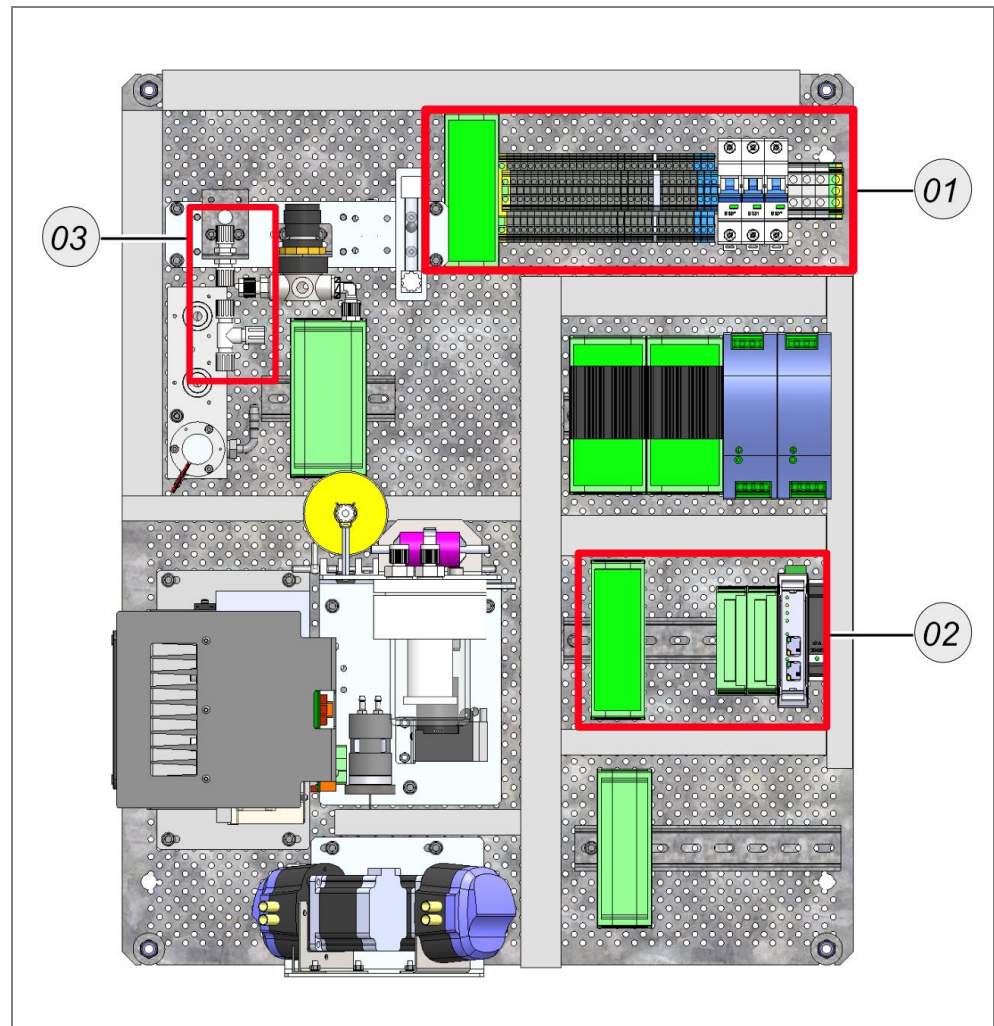

Position	Connection-name	Description
1	X0	Mains
1	X1	Heated sampling line connectors
2	X-2	RS-485 connector
2	Q3 on X3	Alarmrelais
2	X3	IO-Module (Option)
2	X3	Ethernet-Module (Option)
2	X3	Profibus-Module (Option)
3	----	Sample gas inlet

12 Maintenance: Option HD Probe with back-purge

In this part you will learn how to use the *spare part set HD probe #60912-3* correctly, for the maintenance of the HD probe.

⚠ DANGER

Risk due to toxic gases

Noxious gases are sucked in by the measuring device and released into the ambient air.

- Only use the measuring device in well ventilated spaces.
- Always connect a hose to the vent.
- Always lead the hose into an area that is empty of people.

⚠ WARNING

Qualified personnel

The units may only be installed and commissioned by qualified and competent personnel.

⚠ WARNING

Risk due to compressed air

This may result in injuries.

- Connection with the specifications in the operating instructions.
- Depressurize the system before assembly installation or removal.

12.1 Contents: Spare parts set HD probe SWG #60912-3

#	Description	Article-number
1	Ceramic filter	55764
2	Ceramic filter seals	55110
3	Flat gasket 3/4" for probe tube	54899
4	Flange gasket DN 65 PN6	52556
5	O-ring 80 x 3,0 mm Viton 500	61578
6	O-ring 60 x 3,0 mm Viton 500	59104
7	O-ring 22 x 3,0 mm Viton 500	55648
8	Ceramic tube 50 g	64977

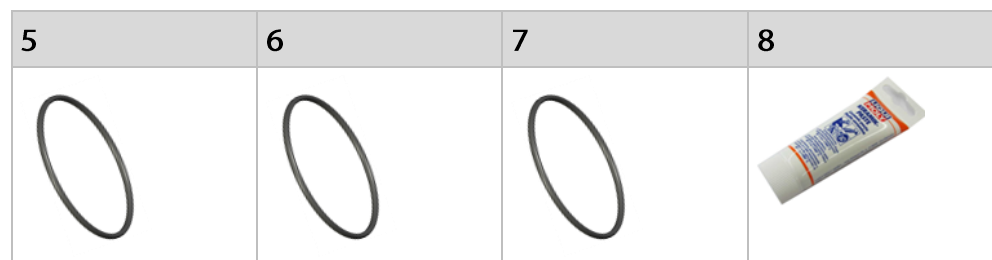
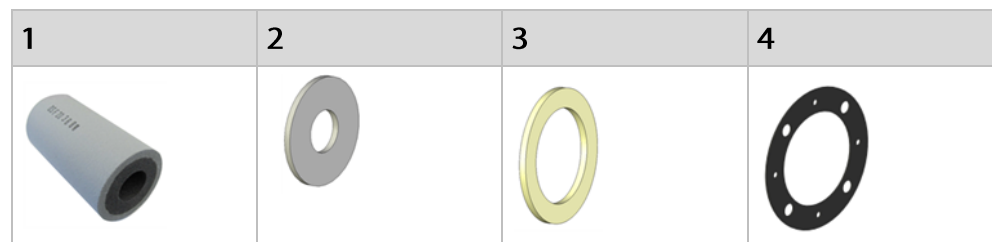

12.2 HD probe: Replace ceramic filter

- ▶ Remove the probe cover.
- ▶ Unscrew the filter unit **02**.

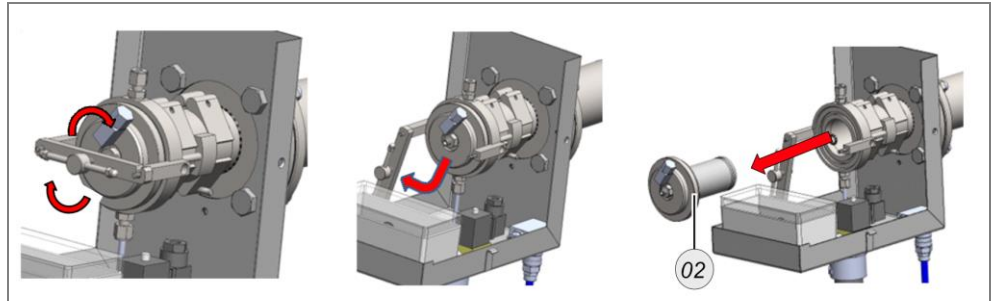

- ▶ Open the filter unit with a *spanner SW 17* **03**.

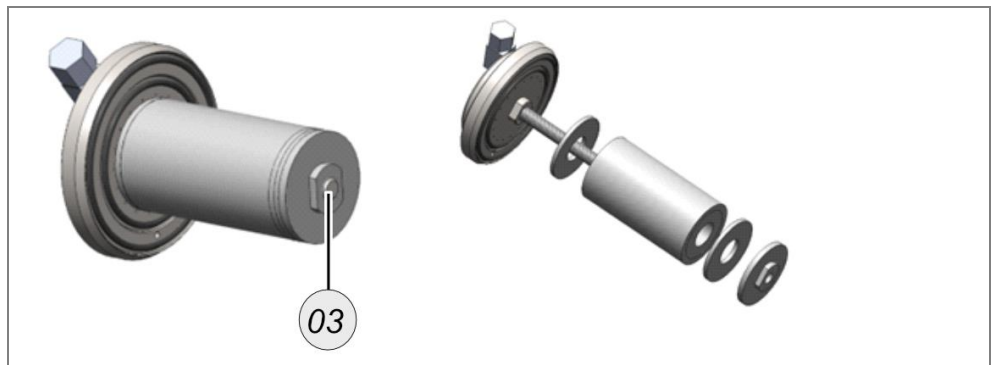

You can see the filter unit, with the different replacement parts.

- ▶ Remove the old ceramic filter **05** and the two ceramic filter seals **04**.



- ▶ Replace the *O-ring 80 x 3.0 mm #61578* **06** and the *O-ring 60 x 3.0 mm #59104* **07**.

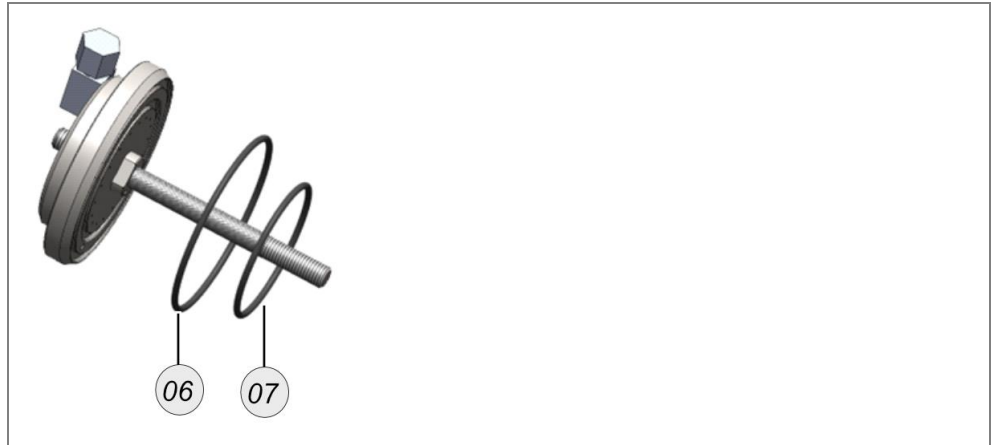

- ▶ Unscrew the **nut** 08 on the filter unit.

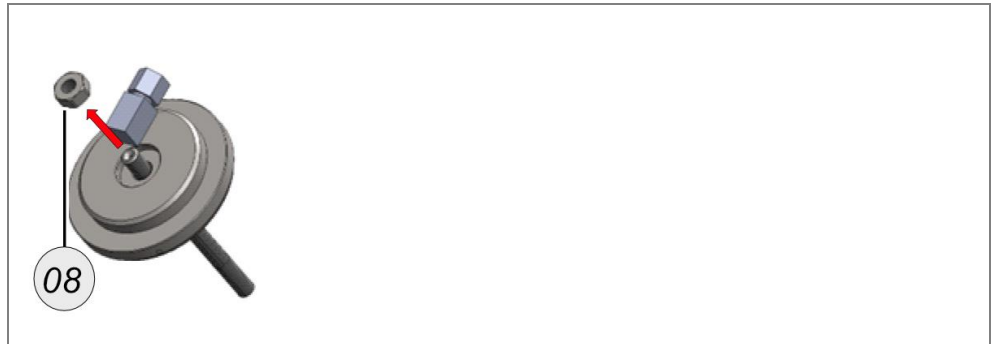

You will see 2 more O-rings.

- ▶ Replace the two **O-rings** #59104 09 and the **O-ring** #55648 10.



- ▶ Screw the filter unit back together with the new ceramic filter and the ceramic filter seals.

✓ The ceramic filter is replaced.

12.3 HP probe: Replacing the flange seals

- ▶ Loosen the screws **01** from the mounting flange.

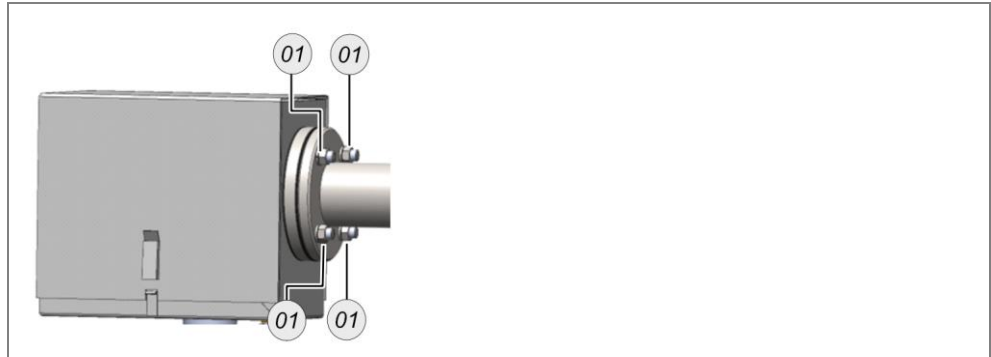

- ▶ Carefully slide the HP probe out of the mounting flange.

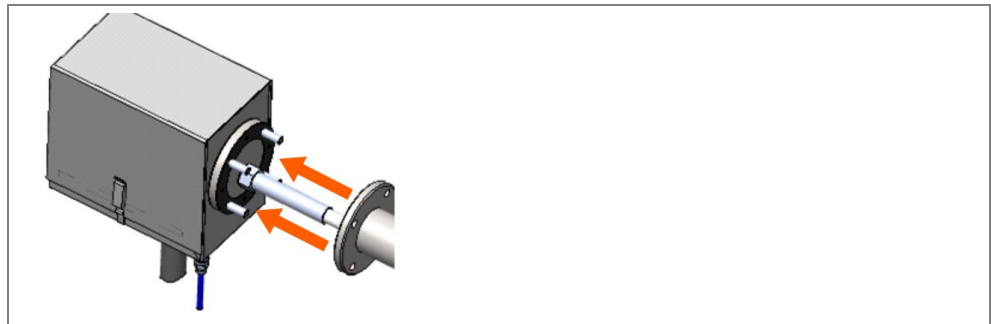

- ▶ Remove the probe tube **04** with a *spanner SW 17*.
- ▶ Replace the *flat gasket 3/4" #54899* **03** with a new one.
- ▶ Replace the *flange gasket DN65 #52556* **04** with a new one.

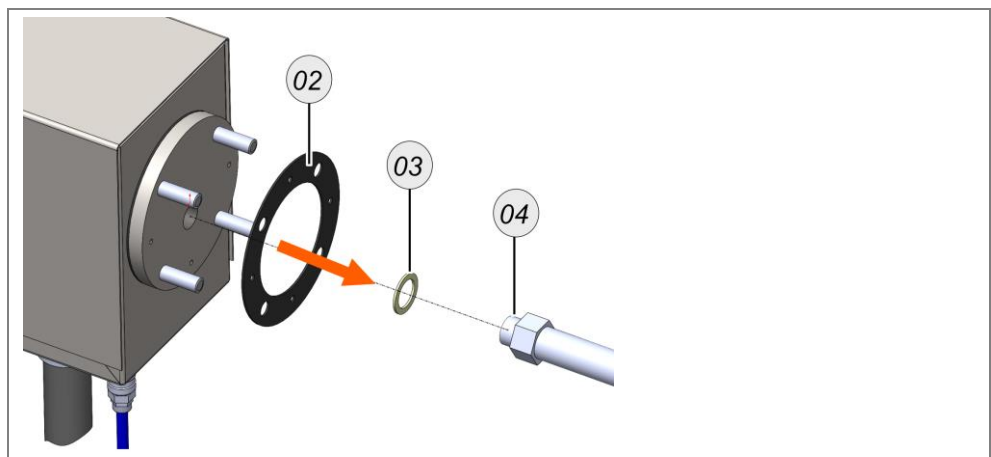

- ▶ Reassemble the probe.

NOTE

When reassembling to the mounting flange, use the ceramic paste to prevent the threads from seizing.

- ✓ You have mounted the seals.

13 Maintenance: Option HD Probe with back-purge

In this part you will learn how to use the *spare part set HD probe #60912-3* correctly, for the maintenance of the HD probe.

⚠ DANGER

Risk due to toxic gases

Noxious gases are sucked in by the measuring device and released into the ambient air.

- Only use the measuring device in well ventilated spaces.
- Always connect a hose to the vent.
- Always lead the hose into an area that is empty of people.

⚠ WARNING

Qualified personnel

The units may only be installed and commissioned by qualified and competent personnel.

⚠ WARNING

Risk due to compressed air

This may result in injuries.

- Connection with the specifications in the operating instructions.
- Depressurize the system before assembly installation or removal.

13.1 Contents: Spare parts set HD probe SWG #60912-3

#	Description	Article-number
1	Ceramic filter	55764
2	Ceramic filter seals	55110
3	Flat gasket 3/4" for probe tube	54899
4	Flange gasket DN 65 PN6	52556
5	O-ring 80 x 3,0 mm Viton 500	61578
6	O-ring 60 x 3,0 mm Viton 500	59104
7	O-ring 22 x 3,0 mm Viton 500	55648
8	Ceramic tube 50 g	64977

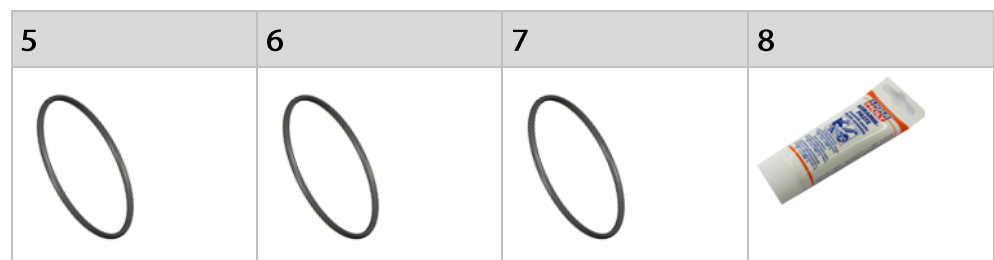
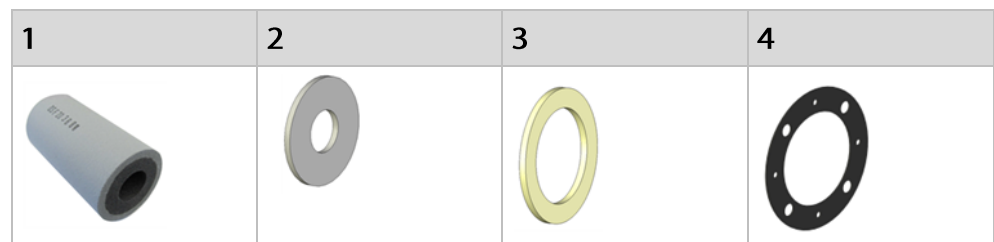

13.2 HD probe: Replace ceramic filter

- ▶ Remove the probe cover.
- ▶ Unscrew the filter unit **02**.

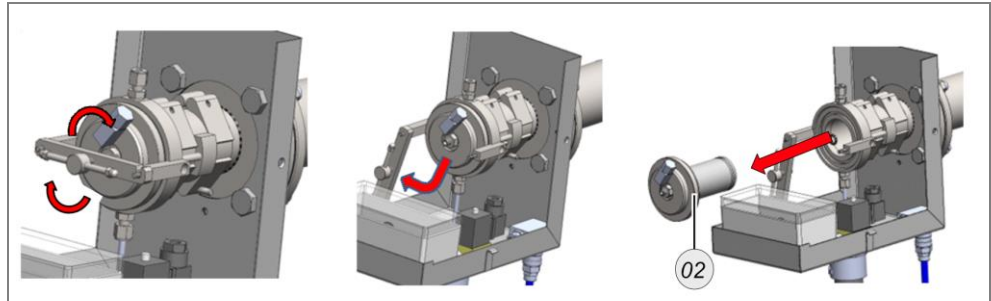

- ▶ Open the filter unit with a *spanner SW 17* **03**.

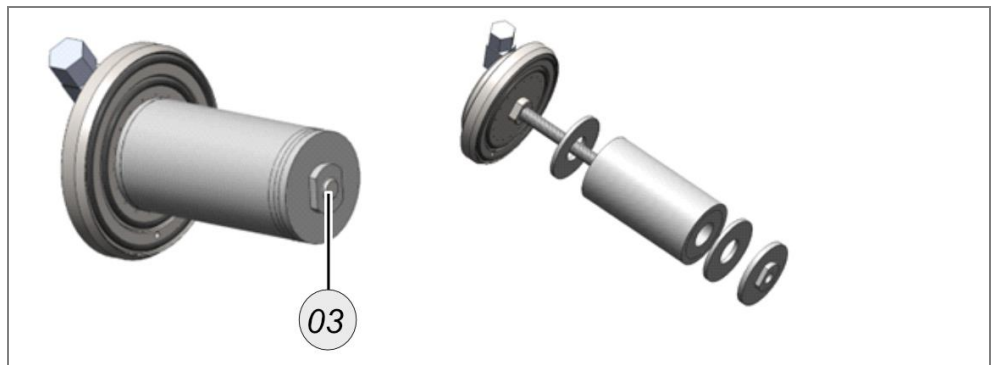

You can see the filter unit, with the different replacement parts.

- ▶ Remove the old ceramic filter **05** and the two ceramic filter seals **04**.

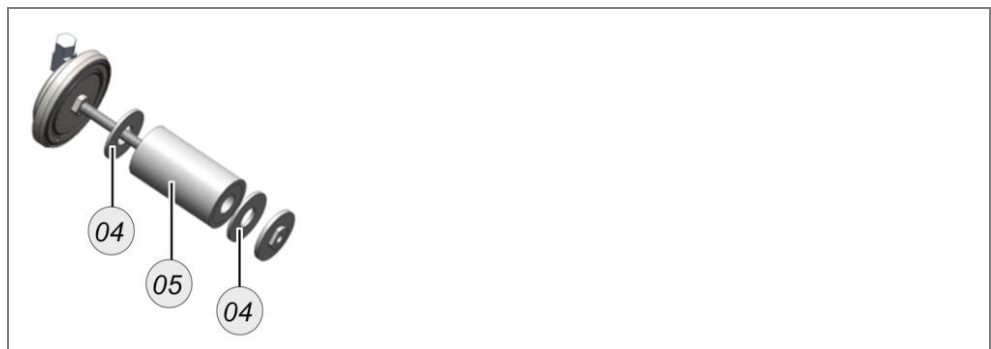

- ▶ Replace the *O-ring 80 x 3.0 mm #61578* **06** and the *O-ring 60 x 3.0 mm #59104* **07**.

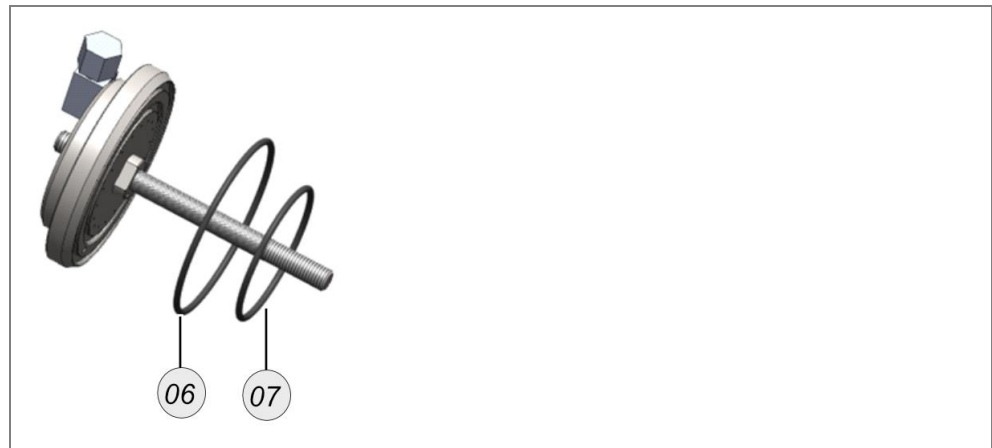

▶ Unscrew the **nut** **08** on the filter unit.



You will see 2 more O-rings.

▶ Replace the two **O-rings** #59104 **09** and the **O-ring** #55648 **10**.



▶ Screw the filter unit back together with the new ceramic filter and the ceramic filter seals.

✓ The ceramic filter is replaced.

13.3 HP probe: Replacing the flange seals

- ▶ Loosen the screws **01** from the mounting flange.

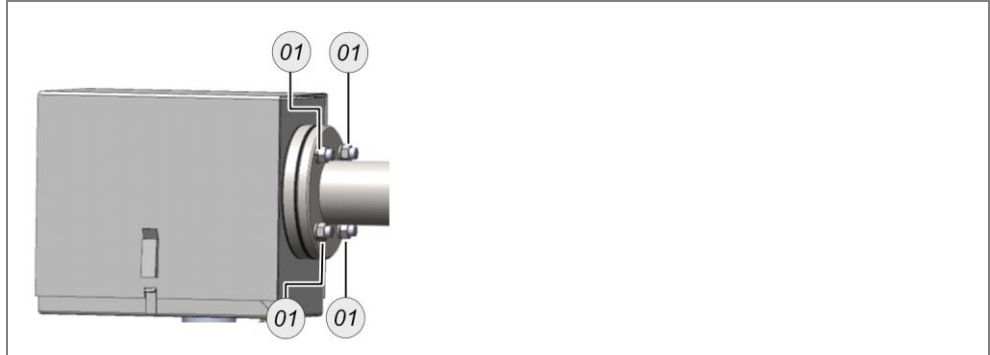

- ▶ Carefully slide the HP probe out of the mounting flange.

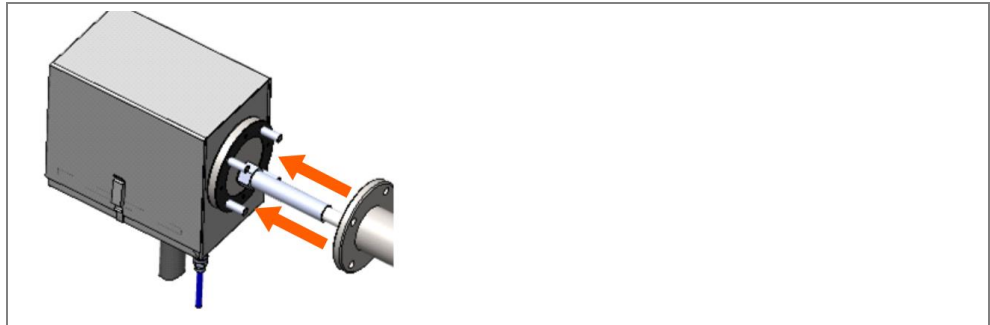

- ▶ Remove the probe tube **04** with a *spanner SW 17*.
- ▶ Replace the *flat gasket 3/4" #54899* **03** with a new one.
- ▶ Replace the *flange gasket DN65 #52556* **04** with a new one.

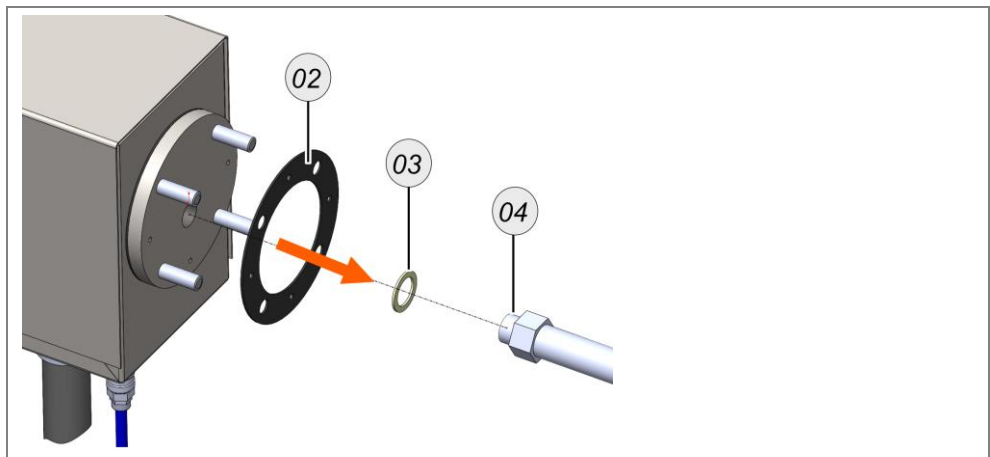

- ▶ Reassemble the probe.

NOTE

When reassembling to the mounting flange, use the ceramic paste to prevent the threads from seizing.

- ✓ You have mounted the seals.

13.4 HD-probe dimensions

